

- 1.0 GENERAL NOTES  
 1.1 ALL METRIC DIMENSIONS ARE IN BRACKETS [X. X]  
 1.2 FOR PATENT INFO: <https://www.cs-pat.com>  
 2.0 DESIGN NOTES  
 2.1 FITS TOWER LEGS UP TO 16" ROUND OR 60° ANGLE, 12" 90° ANGLE.  
 3.0 MANUFACTURING/SPECIAL REQUIREMENTS  
 3.1 TIGHTEN ALL BOLTS SECURING FLAT PLATES BY THE TURN-OF-NUT METHOD. TIGHTEN ALL U-BOLTS USING TURN-OF-NUT METHOD WITH ATTENTION TO LEAVE EQUAL DISTANCE AND EQUAL FORCE ON EACH LEG OF THE U-BOLT.  
 4.0 TEST  
 5.0 PACKAGING  
 5.1 PACKAGING SHALL MEET COMMSCOPE REQUIREMENTS PER DOCUMENT IS-PL-3005.  
 5.2 PRINTED DOCUMENT TO BE PLACED INSIDE POLYBAG AND THEN IN SHIPPING CONTAINER.  
 5.3 EXTRA HARDWARE MAY BE SUPPLIED, BAGGED AND SHIPPED.

REVISIONS			
REV.	DESCRIPTION	DATE	APPROVED
A	INDIVIDUAL DRAWING INITIAL RELEASE	YX1027 14JUN24	AIBIN 40198118CMO

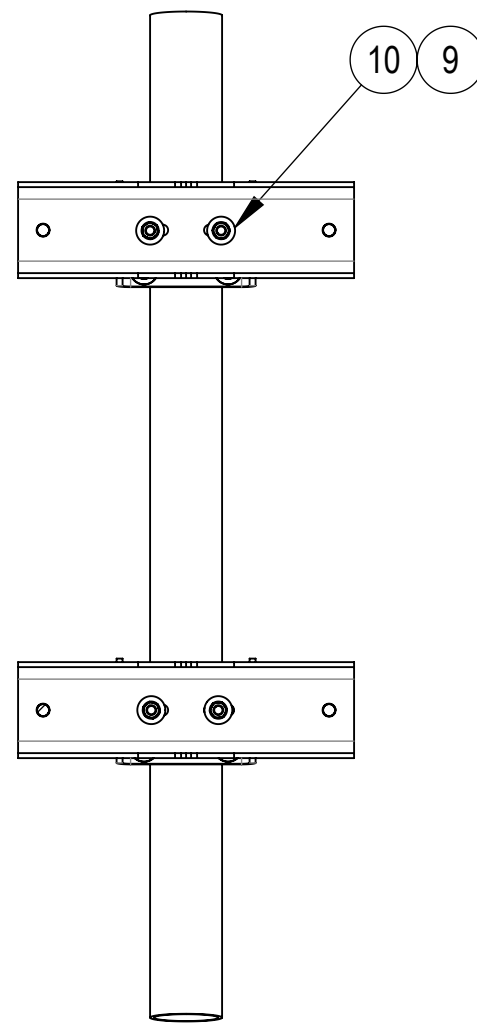

SECTION A-A

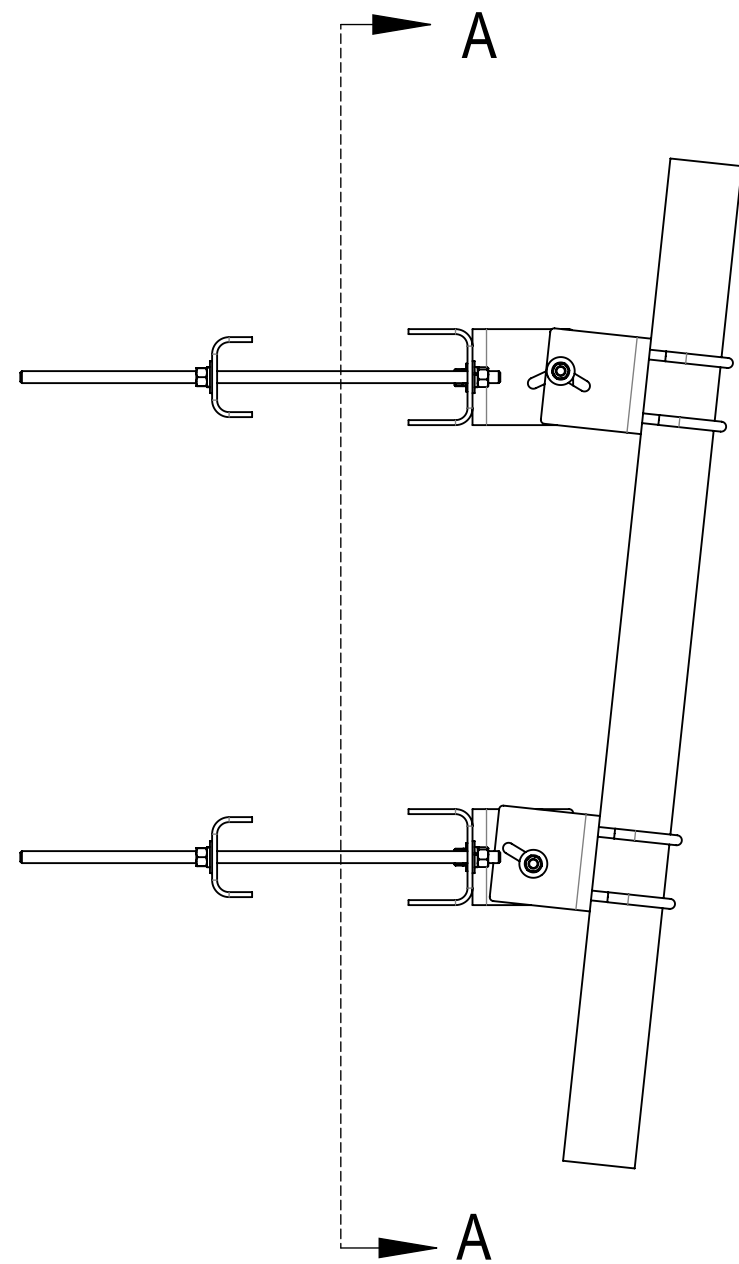
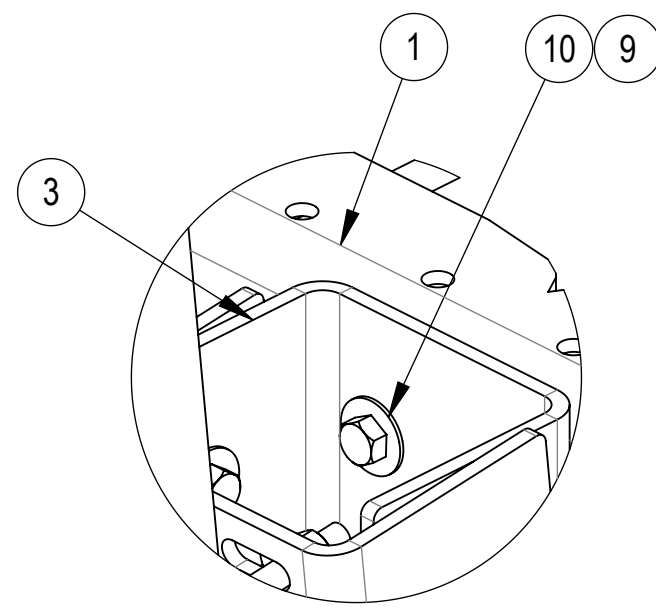
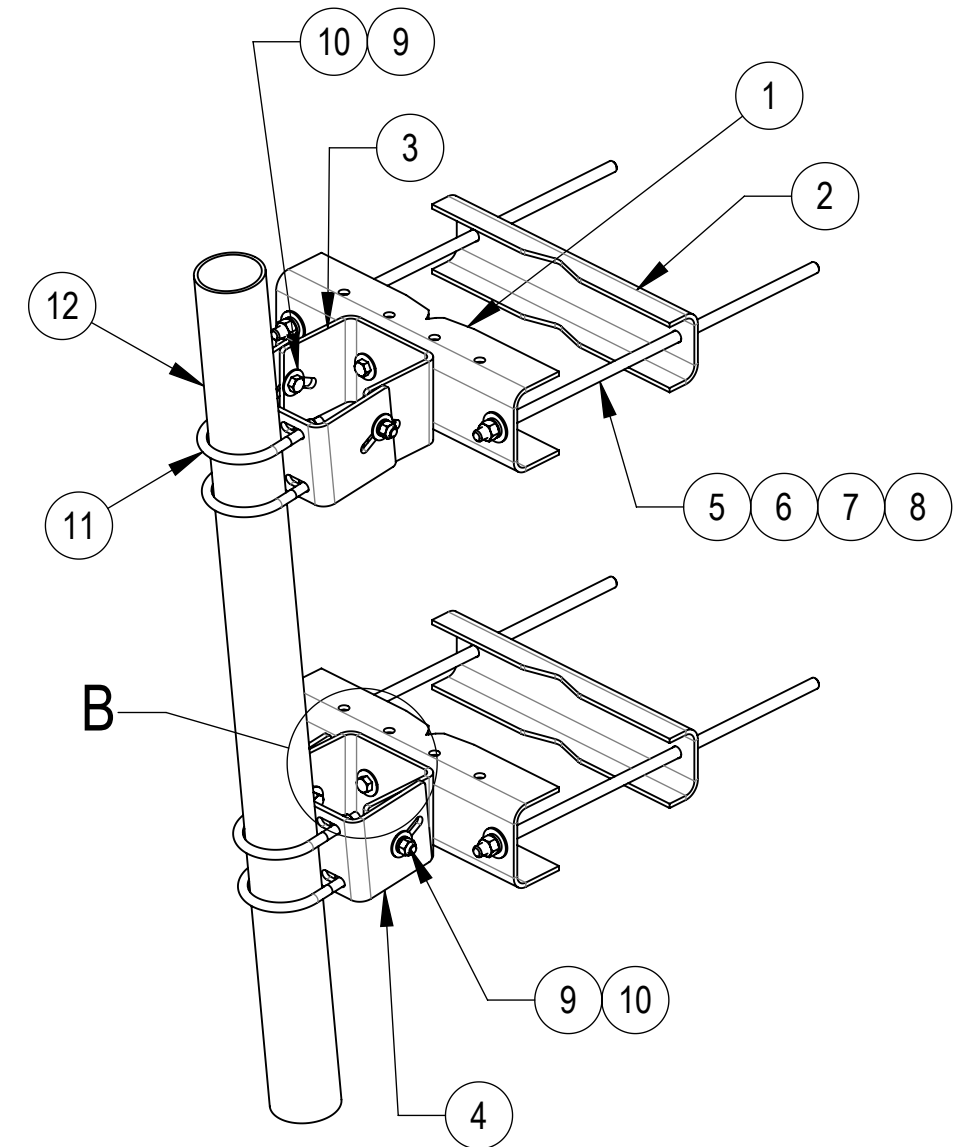

DETAIL B  
SCALE 1 : 4

COMPONENT PART NUMBERS PROVIDED FOR ASSEMBLY PURPOSES;  
INDIVIDUAL COMPONENTS MAY BE SHIPPED AS PARTS WITHIN AN INCLUDED KIT.

ITEM NO.	PART NUMBER	DESCRIPTION	QTY.	WEIGHT	NOTE NO.
1	SMU201601	LARGE SADDLE MOUNT, 16" TOWER LEG	2	22.4 LBS	
2	SMU201602	CLAMP PLATE	2	15.5 LBS	
3	MTC985101	INNER CHANNEL FOR MTC9851 MOUNT	2	11.52 LBS	
4	MTC985102	OUTER CHANNEL	2	11.8 LBS	
5	MT38430B7	3/4" X 30" GALV THREADED ROD, GRADE B7	4	3.7 LBS	
6	GW-06	3/4" GALV FLAT WASHER	8	0.10 LBS	
7	GWL-06	3/4" GALV LOCK WASHER	8	0.04 LBS	
8	GN-06	3/4" GALV HEX NUT	8	0.15 LBS	
9	GB-0520A	5/8" X 2" GALV BOLT KIT (A325)	8	0.26 LBS	
10	GW-05	5/8" GALV FLAT WASHER, 1.7OD	16	0.06 LBS	
11	GUB-5456	5/8" X 4-5/8" X 6 1/2" GALV U-BOLT	4	1.4 LBS	
12	MT-653-63	4.5" O.D. X 63" PIPE	1	57.02 LBS	

DENSITY	207.52	lbs/in <sup>3</sup>
MASS	207.52	lbs
VOLUME	736.24	in <sup>3</sup>
SURFACE AREA	5307.96	in <sup>2</sup>
HEIGHT	63.12"	
LENGTH	21"	
WIDTH	45.11"	

© 2024 CommScope, Inc. Confidential

<b>COMMSCOPE, INC. OF NORTH CAROLINA</b>			
TOLERANCES		SAP MATERIAL MASTER	
1 PLACE .X[X] ± .12[0.3]	3 PLACE .XXX[X] ± .03[0.8]	<b>PML-SC4-63</b>	
2 PLACE .XX[X] ± .06[1.5]	ANGLES ± 2°		
FINISH		MATERIAL	
UNLESS OTHERWISE SPECIFIED DIMENSIONS ARE IN INCHES INTERPRET PER ANSI Y 14.5M-1994	NAME	DATE	TITLE
	CE YX1027	14JUN24	LL UNIV. OPEN FACE PIPE MNT ,4-1/2"ODX63"
	RW YX1027	06/14/2024	
	AD YMENG	06/21/2024	
	RE YMENG	06/26/2024	
ECN 40198118CMO			
SCALE	DOCUMENT NO.		
<b>1:12</b>	<b>PML-SC4-63</b>		
SIZE	Auth Group	INSL	MODEL
<b>C</b>			
VERSION	STATUS	REVISION	DRAWING
01	RE	B	VERSION STATUS REVISION
			00 RE A
			SHEET
			1 OF 1