

4

3

2

1

- 1.0 GENERAL NOTES
  - 1.1 ALL METRIC DIMENSIONS ARE IN BRACKETS [X.X]
  - 1.2 FOR PATENT INFO: <https://www.cs-pat.com>
- 2.0 DESIGN NOTES
- 3.0 MANUFACTURING/SPECIAL REQUIREMENTS
  - 3.1 TIGHTEN ALL BOLTS SECURING FLAT PLATES BY THE TURN-OF-NUT METHOD. TIGHTEN ALL U-BOLTS USING TURN-OF-NUT METHOD WITH ATTENTION TO LEAVE EQUAL DISTANCE AND EQUAL FORCE ON EACH LEG OF THE U-BOLT.
- 4.0 TEST
- 5.0 PACKAGING
  - 5.1 PACKAGING SHALL MEET COMMScope REQUIREMENTS PER DOCUMENT IS-PL-3005
  - 5.2 PRINTED DOCUMENT TO BE PLACED INSIDE POLYBAG AND THEN IN SHIPPING CONTAINER
  - 5.3 EXTRA HARDWARE MAY BE SUPPLIED, BAGGED AND SHIPPED

REVISIONS			
REV.	DESCRIPTION	DATE	APPROVED
F	REDRAWN INDIVIDUAL DRAWING	RY1002 18JUL24	BCROSS 40200320CMO

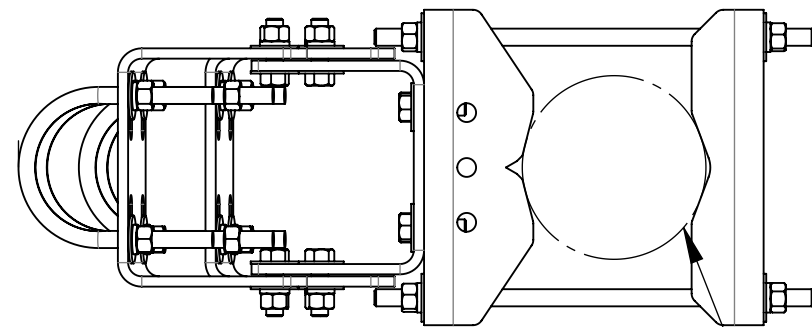

FOR POLES UP TO 8" OD  
 FOR 90° ANGLES UP TO 6"  
 FOR 60° ANGLES UP TO 8"

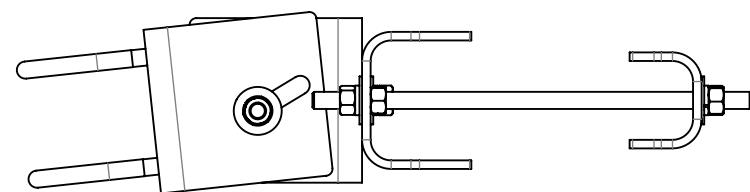
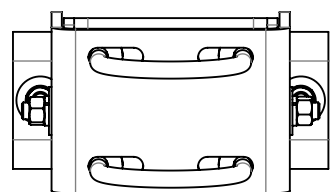
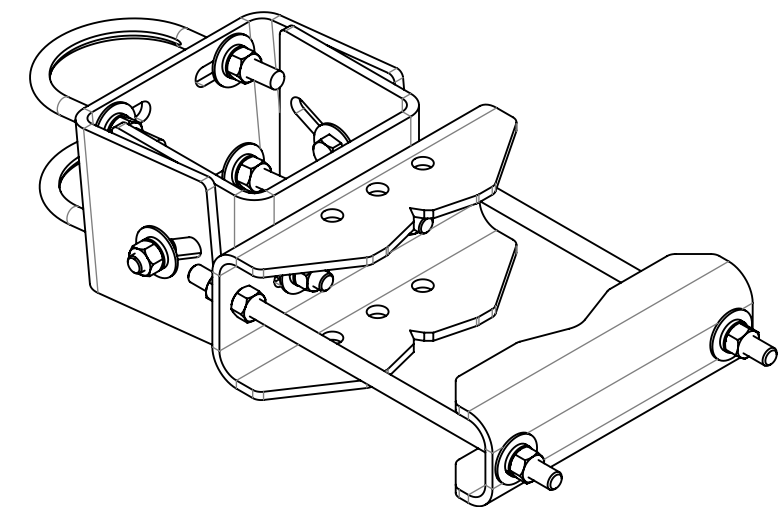
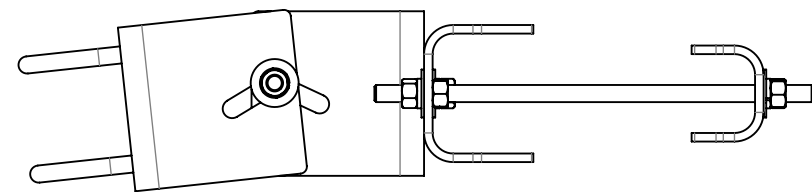
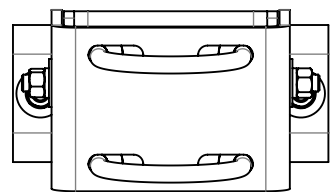
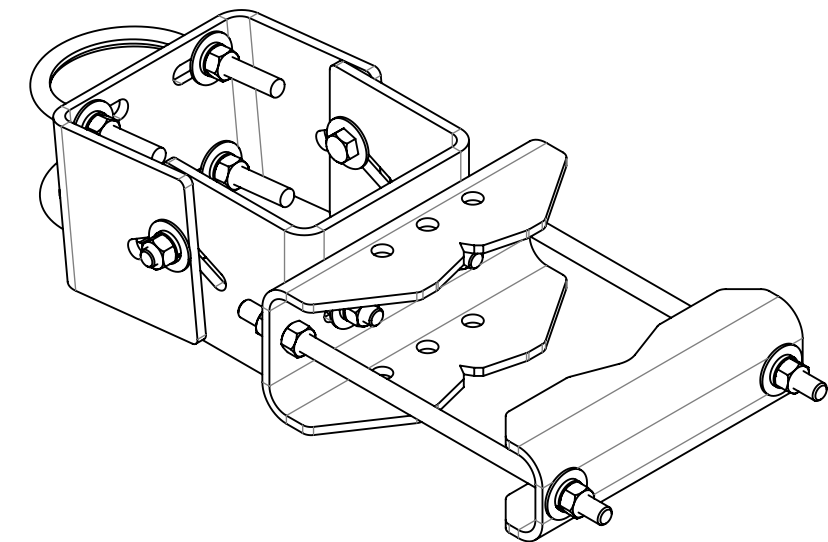

<b>COMMScope, INC. OF NORTH CAROLINA</b>											
TOLERANCES					SAP MATERIAL MASTER						
1 PLACE .X[X] ± 0.2[6.3]			3 PLACE .XXX[X] ± 0.060[1.5]		<b>PM-SC4-B</b>						
2 PLACE .XX[X] ± 0.12[3.0]			ANGLES ± 2°								
FINISH					MATERIAL						
UNLESS OTHERWISE SPECIFIED DIMENSIONS ARE IN INCHES INTERPRET PER ANSI Y 14.5M-1994	NAME		DATE		<b>UNIV OPEN FACE PIPE MOUNT FOR 4-1/2" OD</b>						
	CE	RY1002	18JUL24								
	RW	RY1002	07/18/2024								
	AD	YMENG	07/23/2024								
	RE	YMENG	07/23/2024								
ECN 40200320CMO					SCALE <b>1:7</b>		DOCUMENT NO. <b>PM-SC4-B</b>				
SIZE		Auth Group		INSL		MODEL			DRAWING		
<b>C</b>						VERSION	STATUS	REVISION	VERSION	STATUS	REVISION
						01	RE	F	00	RE	F
SHEET 1 OF 2											

DENSITY		lbs/in <sup>3</sup>
MASS	98.58	lbs
VOLUME	349.03	in <sup>3</sup>
SURFACE AREA	2450.77	in <sup>2</sup>
HEIGHT	36"	
LENGTH	28"	
WIDTH	12"	

4

3

2

1

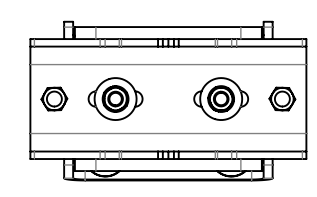
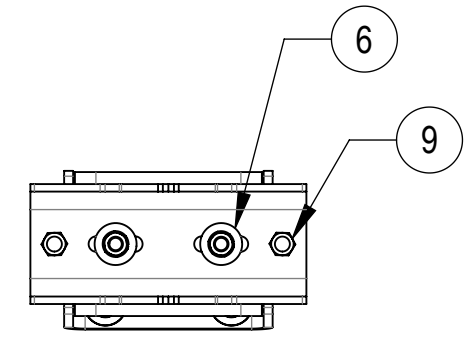
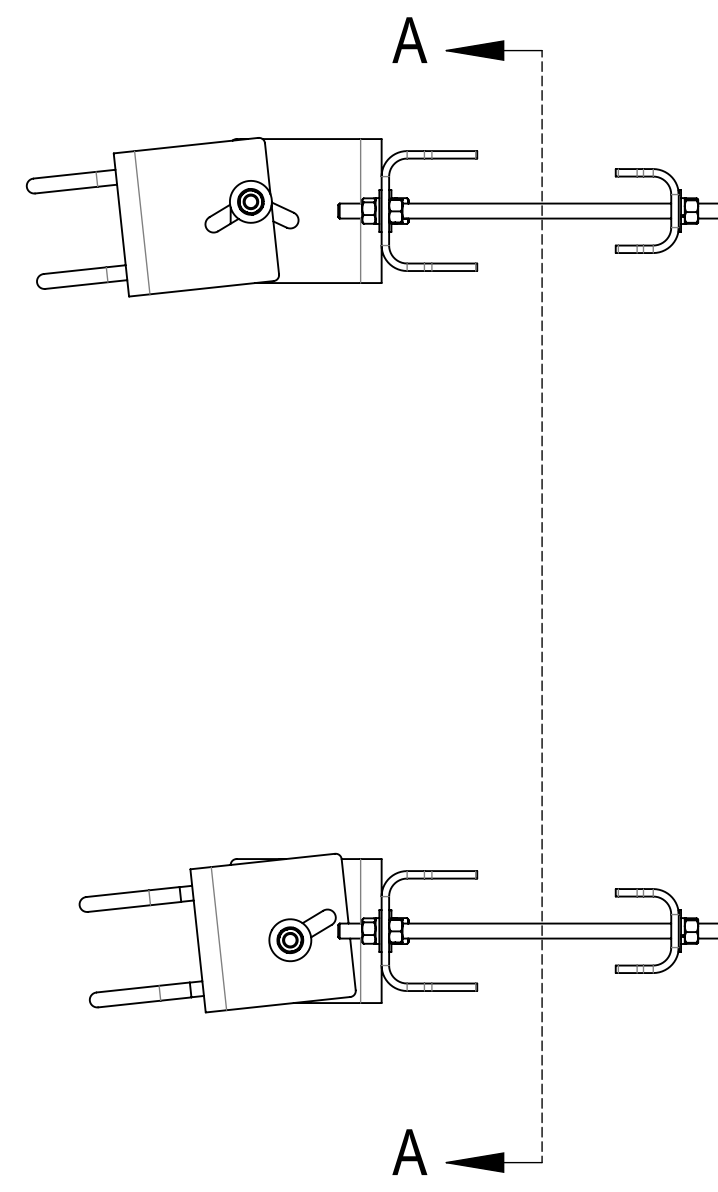

SECTION A-A

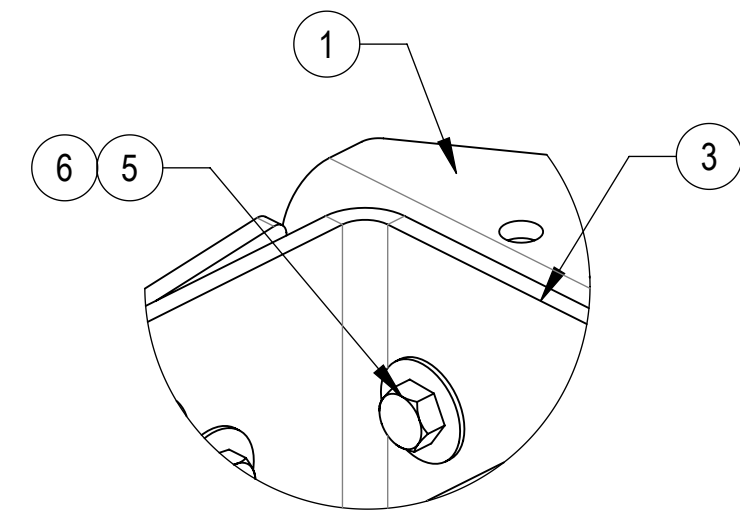
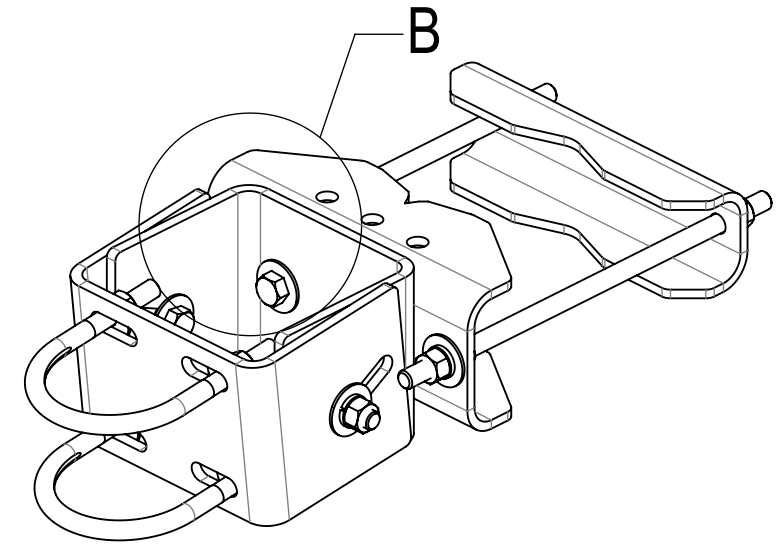
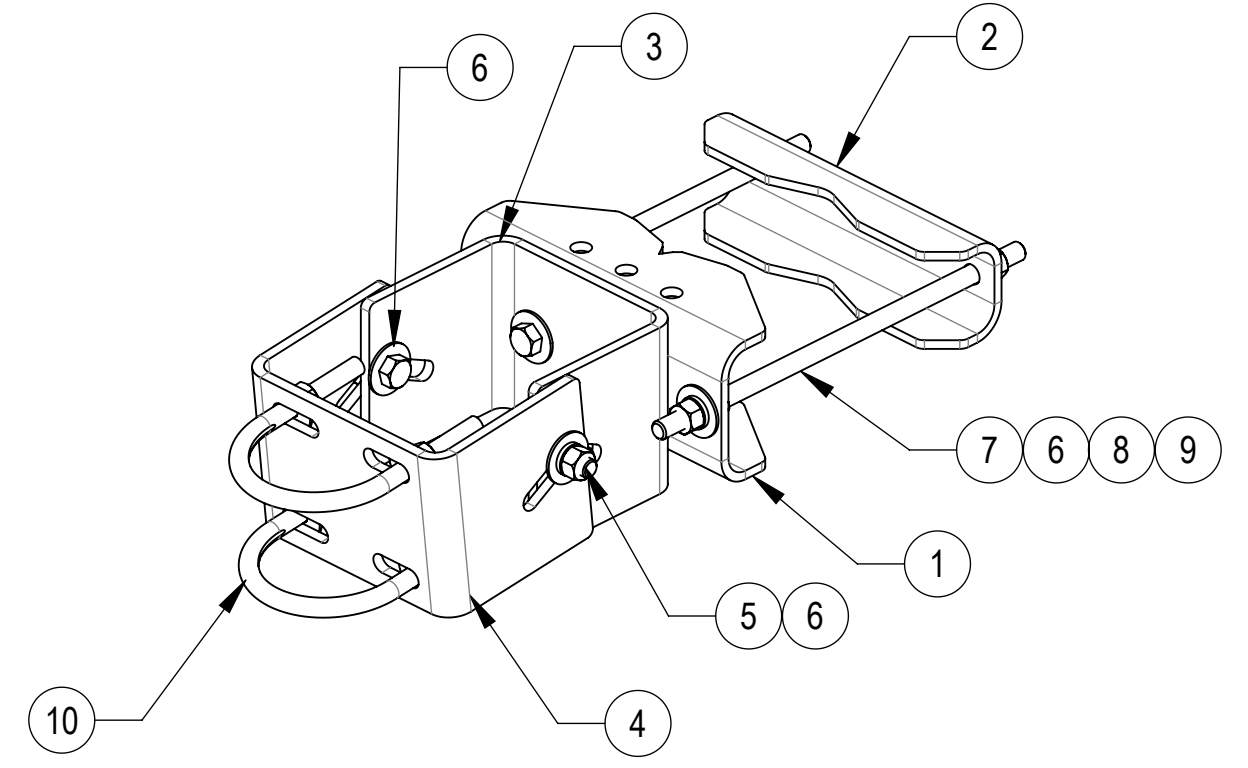

DETAIL B  
SCALE 1 : 3

COMPONENT PART NUMBERS PROVIDED FOR ASSEMBLY PURPOSES;  
INDIVIDUAL COMPONENTS MAY BE SHIPPED AS PARTS WITHIN AN INCLUDED KIT.

ITEM	PART NO.	DESCRIPTION	QTY.	WEIGHT	NOTE NO.
1	MTC397522	CLAMP, FRONT MOUNTING	2	10.02 LBS	
2	MTC397521	CLAMP, BACK	2	6.94 LBS	
3	MTC985101	INNER CHANNEL FOR MTC9851 MOUNT	2	11.52 LBS	
4	MTC985102	OUTER CHANNEL	2	11.78 LBS	
5	GB-05205	5/8" X 2" GALV BOLT KIT	8	0.26 LBS	
6	GW-05	5/8" GALV FLAT WASHER, 1.70D	24	0.06 LBS	
7	MT-382-16	5/8" X 16" GALV THREADED ROD	4	1.38 LBS	
8	GW-05	5/8" GALV LOCK WASHER	8	0.03 LBS	
9	GN-05	5/8" GALV HEX NUT	12	0.08 LBS	
10	GUB-5456	5/8" X 4-5/8" X 6 1/2" GALV U-BOLT	4	1.43 LBS	

COMMSCOPE, INC. OF NORTH CAROLINA				
TITLE UNIV OPEN FACE PIPE MOUNT FOR 4-1/2" OD				
SIZE <b>C</b>	SCALE <b>1:8</b>	DOCUMENT NO. <b>PM-SC4-B</b>		
DRAWING		VERSION	STATUS	REVISION
		00	RE	F
				SHEET 2 OF 2

© 2024 CommScope, Inc. Confidential

4

3

2

1