

- 1.0 GENERAL NOTES
 1.1 ALL METRIC DIMENSIONS ARE IN BRACKETS [X.X]
 1.2 FOR PATENT INFO: <https://www.cs-pat.com>
 2.0 DESIGN NOTES
 3.0 MANUFACTURING/SPECIAL REQUIREMENTS
 3.1 TIGHTEN ALL BOLTS SECURING FLAT PLATES BY THE TURN-OF-NUT METHOD. TIGHTEN ALL U-BOLTS USING TURN-OF-NUT METHOD WITH ATTENTION TO LEAVE EQUAL DISTANCE AND EQUAL FORCE ON EACH LEG OF THE U-BOLT.
 3.2 3 BOLTS AT EACH PANEL CONNECTION.
 3.3 MINIMUM 45 FT-LBS OF TORQUE ON CABLE CLIPS.
 3.4 MUST HAVE ALL 7 GUY CABLE LOCATIONS.
 3.5 BRACKETS ARE MODEL DEPENDENT. BRACKETS CAN BE MOUNTED TO SIDES OR REAR.
 4.0 TEST
 5.0 PACKAGING
 5.1 PACKAGING SHALL MEET COMMScope REQUIREMENTS PER DOCUMENT IS-PL-3005
 5.2 PRINTED DOCUMENT TO BE PLACED INSIDE POLYBAG AND THEN IN SHIPPING CONTAINER
 5.3 EXTRA HARDWARE MAY BE SUPPLIED, BAGGED AND SHIPPED

REVISIONS			
REV.	DESCRIPTION	DATE	APPROVED
K	INITIAL RELEASE	MSM 01OCT14	TP
L	REDRAWN IN SW	YX1027 08AUG24	BA1025 40202084CMO

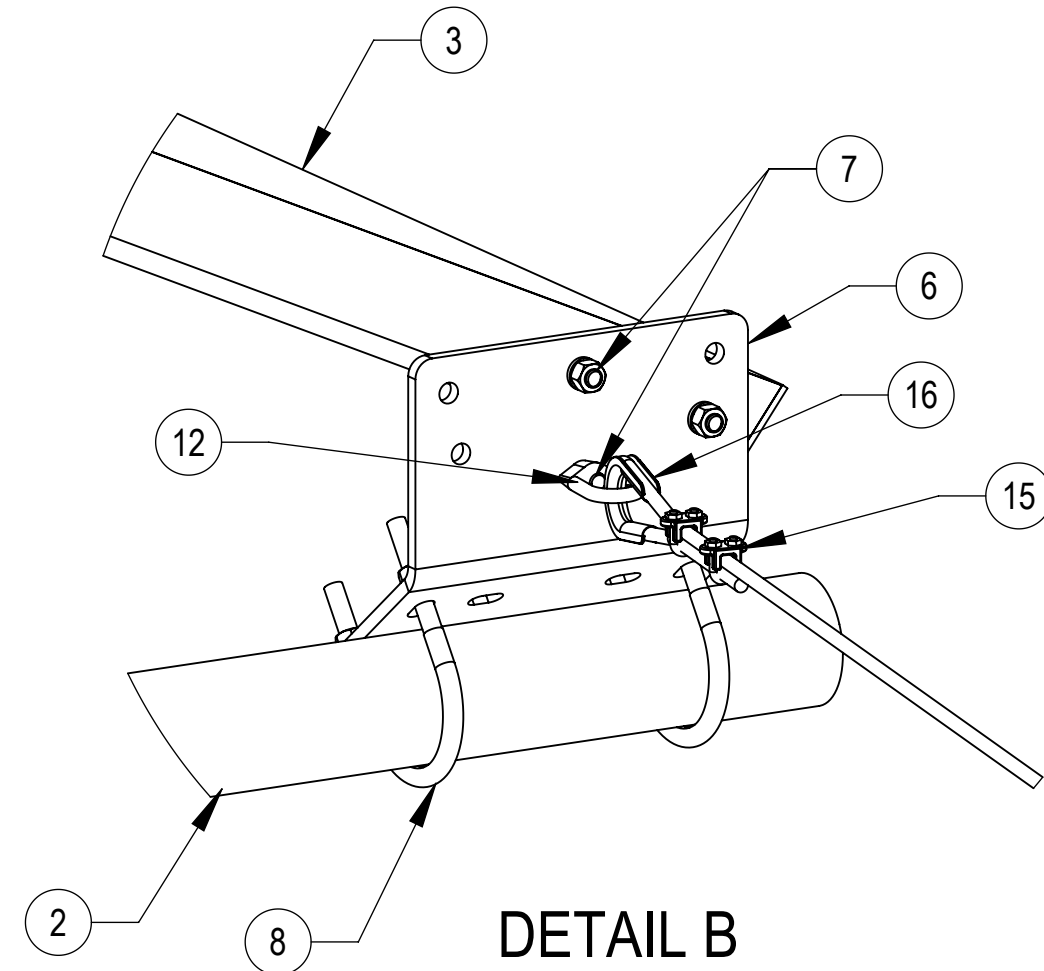

DETAIL B
SCALE 1 : 5

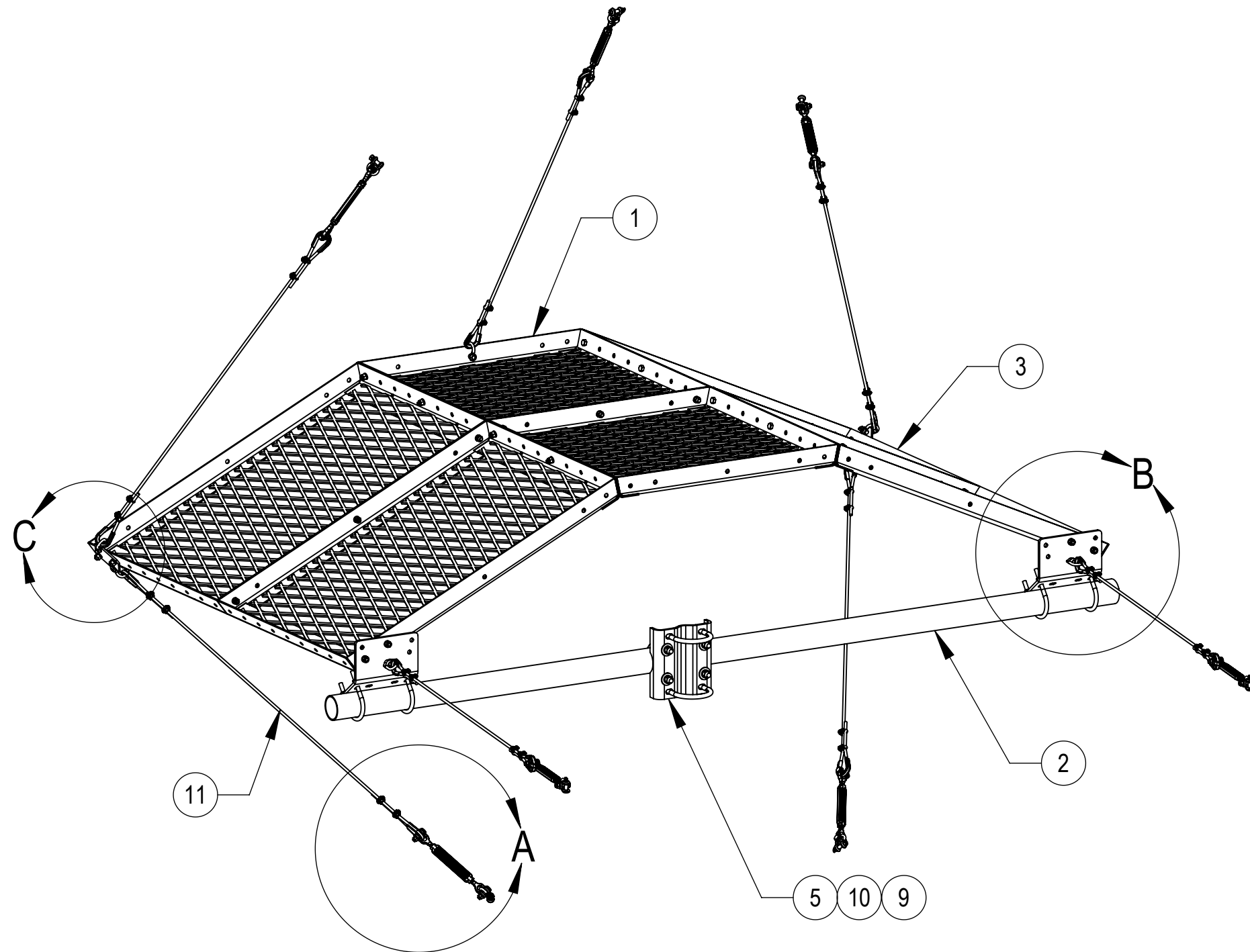
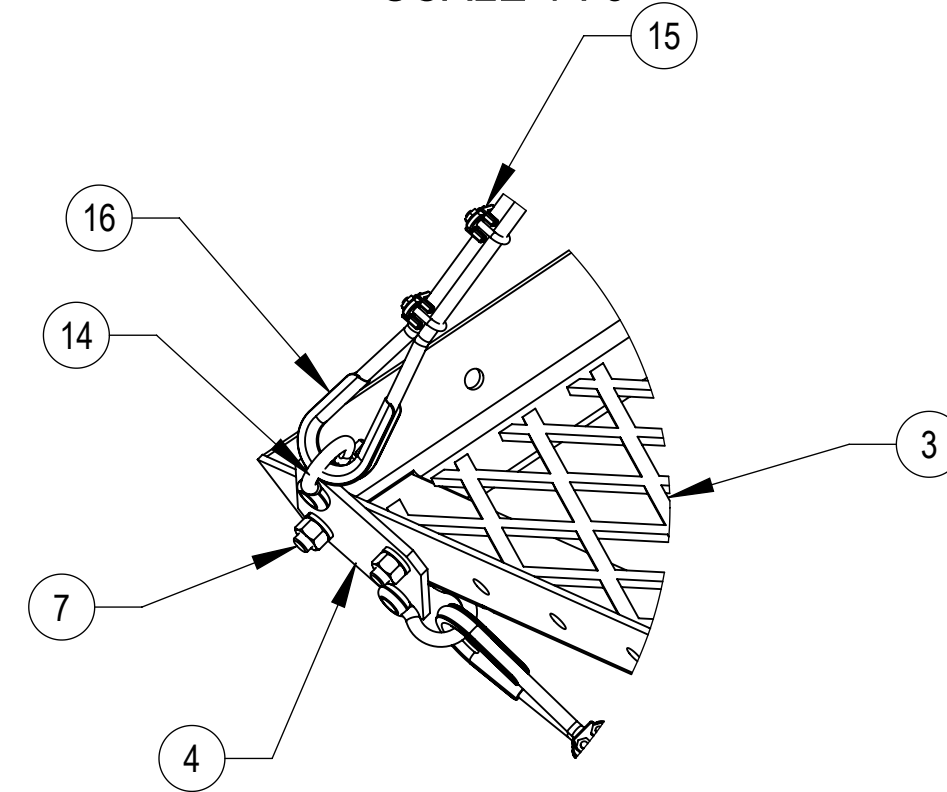

DETAIL C
SCALE 1 : 5

COMPONENT PART NUMBERS PROVIDED FOR ASSEMBLY PURPOSES;
 INDIVIDUAL COMPONENTS MAY BE SHIPPED AS PARTS WITHIN AN INCLUDED KIT.

ITEM	PART NO.	DESCRIPTION	QTY.	WEIGHT	NOTE NO.
1	MDS01	3' X 3' PANEL	2	69.40 LBS	
2	MT-547-126	3.5" O.D. X 126" PIPE	1	61.93 LBS	
3	MDS03	48" X 36" PANEL	4	87.02 LBS	
4	MDS17	SHACKLE PLATE	2	1.32 LBS	
5	MT21613	CENTER BRACKET	1	11.80 LBS	
6	MDS21	CENTER PLATE	2	13.14 LBS	3.5
7	GB-04125	1/2" X 1-1/4" GALV BOLT KIT	31	0.12 LBS	
8	GUB-4356	1/2" X 3-5/8" X 6" GALV U-BOLT KIT	4	0.88 LBS	
9	GUB-53560	5/8" X 3-5/8" X 6" GALV U-BOLT	2	1.30 LBS	
10	GUB-5456	5/8" X 4-5/8" X 6 1/2" GALV U-BOLT	2	1.43 LBS	
11	MT-297	7 X19 3/8 (200 FOOT) WIRE ROPE	1	2.46 LBS	
12	MT-309	EYE NUT 3/8" WITH 1/2" THREAD	2	0.26 LBS	
13	MT-320	1/2" X 6" LONG JAW-JAW TURNBUCKLE	7	1.788 LBS	
14	MT-345	3/8 SHACKLE	12	0.33 LBS	
15	MT-326	3/8" CABLE CLIP	28	0.08 LBS	
16	MT-303	3/8" OPEN THIMBLE GALV	14	0.12 LBS	

DENSITY		lbs/in ³
MASS	644.04	lbs
VOLUME	2272.97	in ³
SURFACE AREA	25992.61	in ²
HEIGHT	124.43"	
LENGTH	132.70"	
WIDTH	145.49"	

© 2024 CommScope, Inc. Confidential



COMMScope, INC. OF NORTH CAROLINA									
TOLERANCES					SAP MATERIAL MASTER				
1 PLACE .X[X] ± 0.12[3.0]			3 PLACE .XXX[X] ± 0.03[0.8]		MD-S8				
2 PLACE .XX[X] ± 0.06[1.5]			ANGLES ± 2°						
FINISH					MATERIAL				
UNLESS OTHERWISE SPECIFIED DIMENSIONS ARE IN INCHES INTERPRET PER ANSI Y 14.5M-1994		NAME	DATE	TITLE					
CE	MSM	01OCT14	MICROWAVE DISH SHIELD, 8' ANTENNA						
RW	YMENG	08/15/2024							
AD	BA1025	08/16/2024							
RE	YX1027	08/16/2024							
ECN 40202084CMO			SCALE	DOCUMENT NO.					
			1:36	MD-S8					
SIZE	Auth Group	INSL	MODEL			DRAWING			
C			VERSION	STATUS	REVISION	VERSION	STATUS	REVISION	SHEET
			01	RE	M	01	RE	L	1 OF 3

NOTES:

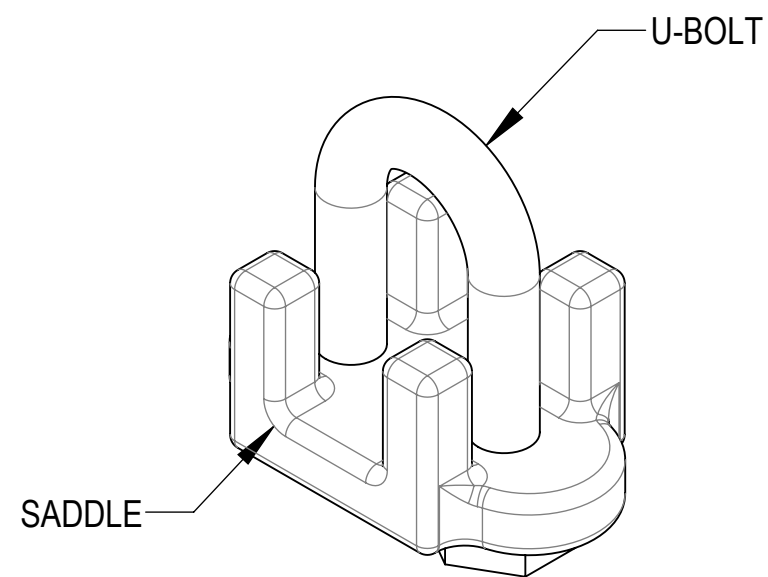
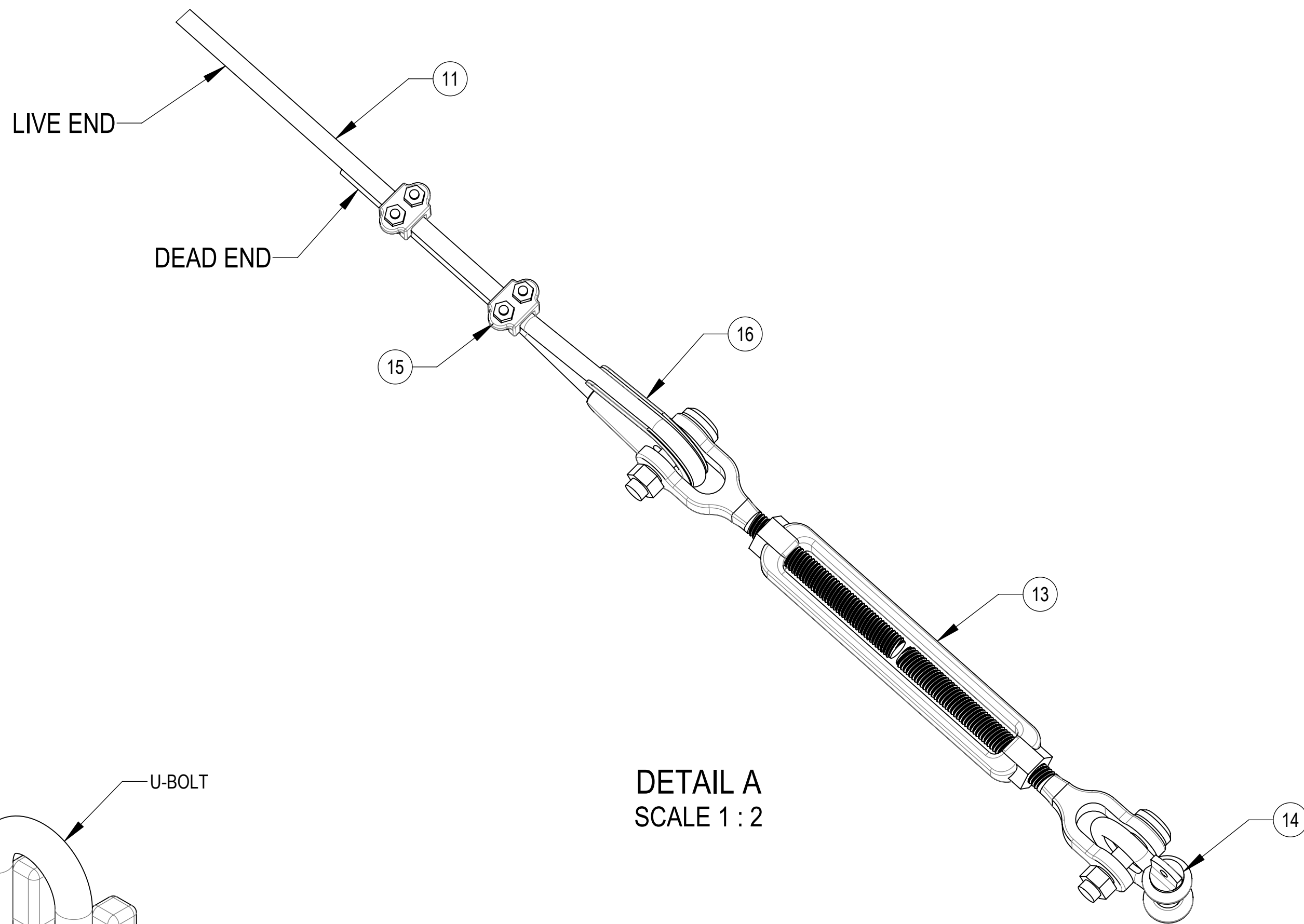
- 1. WIRE ROPE TURN-BACK SHOULD BE 6 1/2" MINIMUM
- 2. APPLY CABLE CLAMP AS SHOWN (SADDLE ON LIVE END OF CABLE)
- 3. USE TORQUE WRENCH TO TIGHTEN U-BOLT EVENLY TO 45LB/FT.
- 4. CABLE CLIPS SHOULD BE 1" FROM END AND 1" FROM THIMBLE.



DETAIL A
SCALE 1 : 2

COMMSCOPE, INC. OF NORTH CAROLINA					
TITLE MICROWAVE DISH SHIELD, 8' ANTENNA					
SIZE C	SCALE 1:36	DOCUMENT NO. MD-S8			
 		DRAWING			SHEET 2 OF 3
		VERSION 01	STATUS RE	REVISION L	

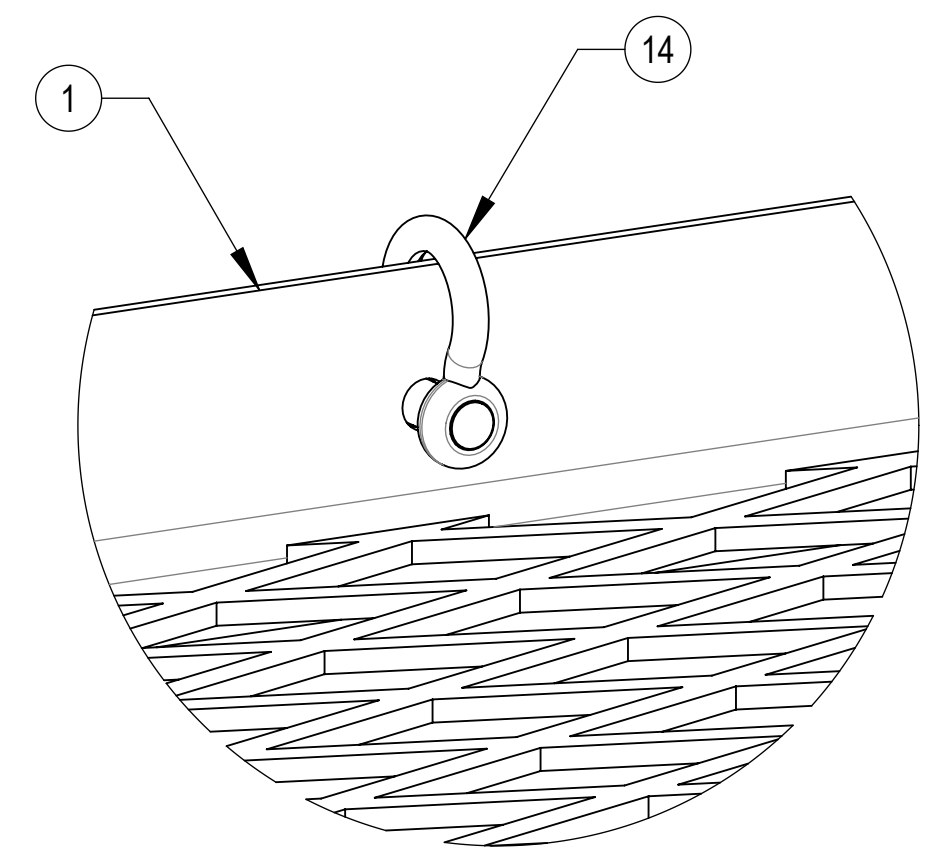
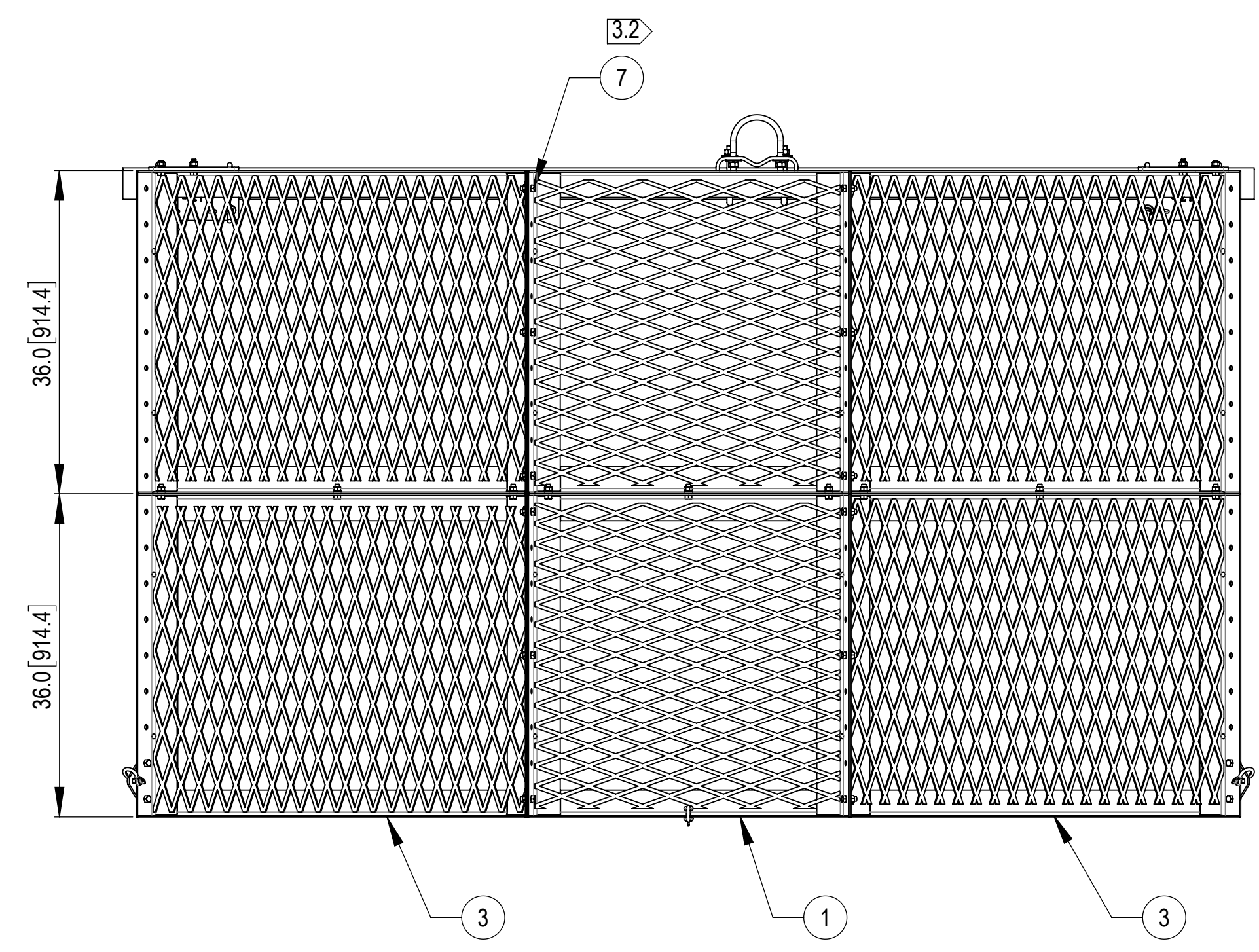
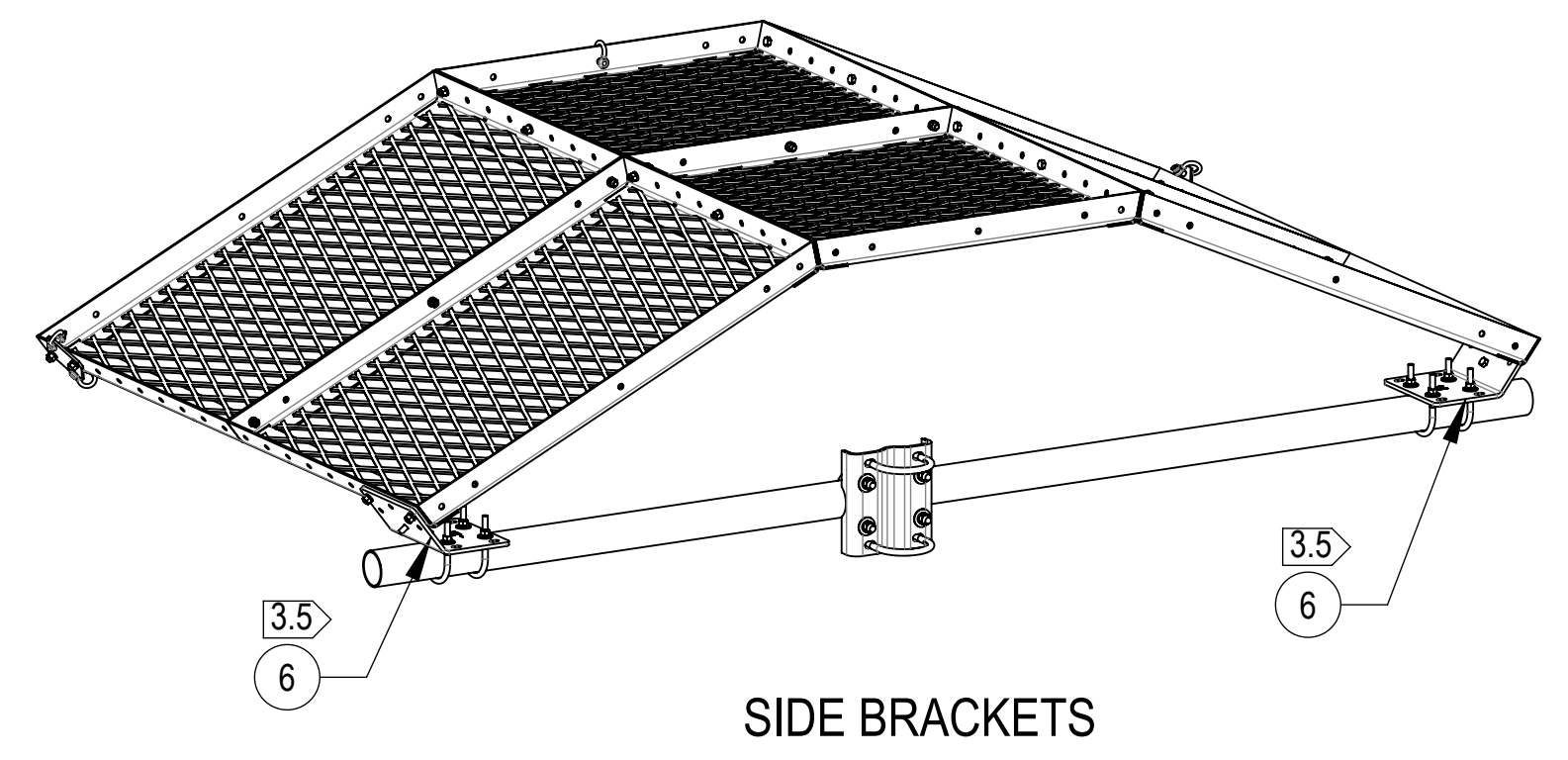
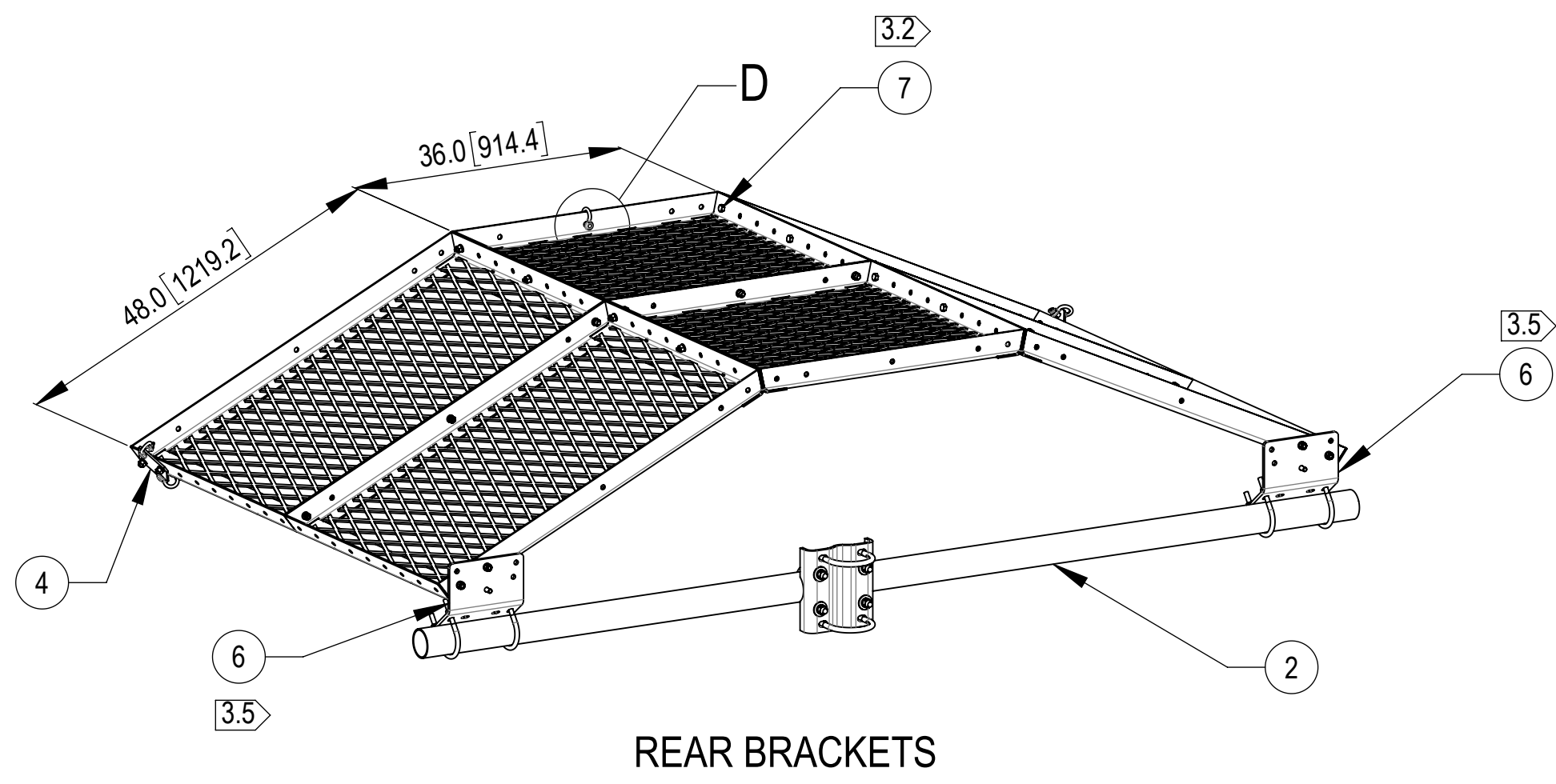

COMMSCOPE, INC. OF NORTH CAROLINA				
TITLE MICROWAVE DISH SHIELD, 8' ANTENNA				
SIZE C	SCALE 1:50	DOCUMENT NO. MD-S8		
		DRAWING		SHEET
		VERSION	STATUS	REVISION
		01	RE	L
				3 OF 3