

VHLP1-80-DET/A

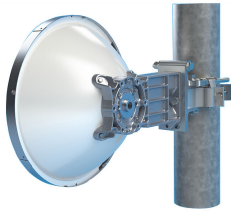

1 ft ValuLine® High Performance Low Profile Antenna, single-polarized, 71.0–86.0 GHz, OEM custom flange, OEM custom colour

Product Classification

Product Type	Microwave antenna
Product Brand	ValuLine®

General Specifications

Antenna Type	VHLP - ValuLine® High Performance Low Profile Antenna, single-polarized
Polarization	Single
Antenna Input	Custom
Antenna Color	Custom
Reflector Construction	One-piece reflector
Radome Color	Custom
Radome Material	Polymer
Flash Included	No
Side Struts, Included	0
Side Struts, Optional	0

Dimensions

Diameter, nominal	0.3 m 1 ft
--------------------------	--------------

Electrical Specifications

Operating Frequency Band	71.000 – 86.000 GHz
Gain, Low Band	43 dBi
Gain, Mid Band	43.5 dBi
Gain, Top Band	44 dBi
Boresite Cross Polarization Discrimination (XPD)	25 dB
Front-to-Back Ratio	61 dB
Beamwidth, Horizontal	0.9 °

VHLP1-80-DET/A

Beamwidth, Vertical	0.9 °
Return Loss	14 dB
VSWR	1.5
Radiation Pattern Envelope Reference (RPE)	7287A
Electrical Compliance	ETSI 302 217 Class 3 US FCC Part 101.115

Mechanical Specifications

Compatible Mounting Pipe Diameter	50 mm–115 mm 2.0 in–4.5 in
Fine Azimuth Adjustment Range	±15°
Fine Elevation Adjustment Range	±15°
Wind Speed, operational	180 km/h 111.847 mph
Wind Speed, survival	250 km/h 155.343 mph

VHLP1-80-DET/A

Antenna Dimensions and Mounting Information

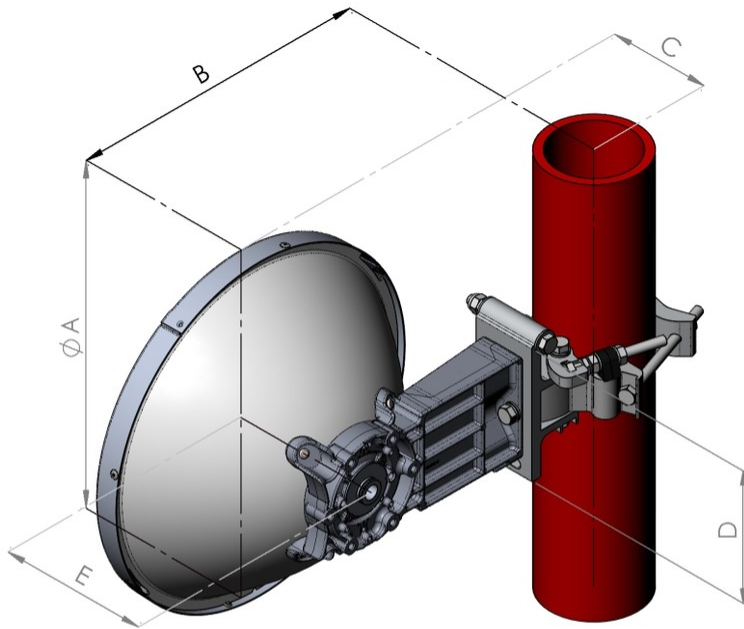

Dimensions in inches (mm)					
Antenna size, ft (m)	A	B	C	D	E
1 (0.3)	15(382)	12.7(323)	6(151)	6.1(155)	7(177)

Wind Forces at Wind Velocity Survival Rating

Axial Force (FA)	445 N 100.04 lbf
Side Force (FS)	200 N 44.962 lbf
Twisting Moment (MT)	144 N-m 1,274.507 in lb
Zcg without Ice	28 mm 1.102 in
Zcg with 1/2 in (12 mm) Radial Ice	54 mm 2.126 in
Weight with 1/2 in (12 mm) Radial Ice	13 kg 28.66 lb

VHLP1-80-DET/A

Wind Forces at Wind Velocity Survival Rating Image



Packaging and Weights

Height, packed	350 mm 13.78 in
Width, packed	400 mm 15.748 in
Length, packed	400 mm 15.748 in
Packaging Type	Standard pack
Volume	0.6 m ³ 21.189 ft ³
Weight, gross	6.2 kg 13.669 lb
Weight, net	4.7 kg 10.362 lb

Regulatory Compliance/Certifications

VHLP1-80-DET/A

Agency

ISO 9001:2015

Classification

Designed, manufactured and/or distributed under this quality management system

* Footnotes

Operating Frequency Band

Bands correspond with CCIR recommendations or common allocations used throughout the world. Other ranges can be accommodated on special order.

Gain, Mid Band

For a given frequency band, gain is primarily a function of antenna size. The gain of Andrew antennas is determined by either gain by comparison or by computer integration of the measured antenna patterns.

Boresite Cross Polarization Discrimination (XPD)

The difference between the peak of the co-polarized main beam and the maximum cross-polarized signal over an angle twice the 3 dB beamwidth of the co-polarized main beam.

Front-to-Back Ratio

Denotes highest radiation relative to the main beam, at $180^\circ \pm 40^\circ$, across the band. Production antennas do not exceed rated values by more than 2 dB unless stated otherwise.

Return Loss

The figure that indicates the proportion of radio waves incident upon the antenna that are rejected as a ratio of those that are accepted.

VSWR

Maximum; is the guaranteed Peak Voltage-Standing-Wave-Ratio within the operating band.

Radiation Pattern Envelope Reference (RPE)

Radiation patterns define an antenna's ability to discriminate against unwanted signals. Under still dry conditions, production antennas will not have any peak exceeding the current RPE by more than 3dB, maintaining an angular accuracy of $\pm 1^\circ$ throughout

Wind Speed, operational

For VHLP(X), SHP(X), HX and USX antennas, the wind speed where the maximum antenna deflection is 0.3 x the 3 dB beam width of the antenna. For other antennas, it is defined as a deflection is equal to or less than 0.1 degrees.

Wind Speed, survival

The maximum wind speed the antenna, including mounts and radomes, where applicable, will withstand without permanent deformation. Realignment may be required. This wind speed is applicable to antenna with the specified amount of radial ice.

Axial Force (FA)

Maximum forces exerted on a supporting structure as a result of wind from the most critical direction for this parameter. The individual maximums specified may not occur simultaneously. All forces are referenced to the mounting pipe.

Side Force (FS)

Maximum side force exerted on the mounting pipe as a result of wind from the most critical direction for this parameter. The individual maximums specified may not occur simultaneously. All forces are referenced to the

VHLP1-80-DET/A

mounting pipe.

Twisting Moment (MT)

Maximum forces exerted on a supporting structure as a result of wind from the most critical direction for this parameter. The individual maximums specified may not occur simultaneously. All forces are referenced to the mounting pipe.

Packaging Type

Andrew standard packing is suitable for export. Antennas are shipped as standard in totally recyclable cardboard or wire-bound crates (dependent on product). For your convenience, Andrew offers heavy duty export packing options.