



HR150 SERIES DEHYDRATOR USER MANUAL

Bulletin AE01B-A0595-001

Rev: A

© 2014 CommScope, Inc. All rights reserved

(06/14)



Contents

Section 1	General Information.....	3
1.1	Introduction.....	3
Section 2	Safety Information	3
Section 3	Equipment.....	4
3.1	Supplied Equipment	5
Section 4	Description.....	6
Section 5	Installation	6
5.1	Unpacking.....	6
5.2	Mounting.....	7
5.2.1	19" Rack Mounting.....	7
5.2.2	Wall Mounting.....	7
5.3	Electrical Connections	7
5.3.1	Power Connections.....	7
5.3.2	Power Connections.....	8
5.4	Pneumatic Connections.....	8
5.4	Operation	8
5.6	Alarms.....	8
Section 6	Corrective Maintenance and Spare Parts	9
Section 7	Outline	10
Section 8	Customer Service	11
8.0	Introduction.....	11
8.1	In Case of Trouble.....	11
8.2	Initial Steps by CommScope	11
8.3	Repair Center Process	11

Section 1 General Information

1.1 Introduction

The HR150 is a heat regenerative air dryer. It utilizes redundant compressors and drying canisters to insure a reliable flow of dry air for pressurization of air cable. The canisters automatically regenerate, eliminating the maintenance associated with typical desiccant dryers.

The HR150 must be located such that only authorized personnel have access.

CAUTION: The HR150 utilizes heat to regenerate the drying canisters. Mount the HR150 at the top of the equipment rack if possible. Should be placed in the top of the equipment rack with nothing mounted above it.



Section 2 Safety Information

Make sure that the information in this document has been understood by the persons performing the procedures:

- Electrical Hazard! Unplug power cord before servicing unit.
- Let unit cool before removing cover.

Section 3 Equipment

Output Pressure	3 kPa (.44 psig), nominal
Maximum Flow Rate	150 lph (5.3 scfh)
Safety Valve	7 kPa (1.0 psig)
Output Air Dew Point	-45°C (-50°F) , nominal
Desiccant Regeneration	Automatic by heat
Regeneration Phase Interval	2 hours heat / 5 hours operation
Alarms	low pressure, high pressure, high humidity (optional)
Low Pressure Alarm	1.5 kPa (0.22 psig)
High Pressure Alarm	4.5 kPa (0.65 psig)
High Humidity Alarm	10% RH
LED Indications	Power on, Alarm codes
Acoustic Noise	50 dBA
Enclosure Degree of Protection	IP20
Operating Temperature	-5°C to +50°C (+23°F to + 122°F)
Storage Temperature	-40°C to +70°C (-40°F to +158°F)
Power Supply Std.	-48 / -60 V DC
Power Consumption	<45 W
Dimensions	2 RU (428 mm x 87 mm x 234 mm) (16.85 in x 3.43 in x 9.21 in)
European Community Directives	CE
Safety Normative	ETSI EN 60950-1 ANSI/UL 60950-1 CAN/CSA-C22.2 No. 60950-1-07
Electromagnetic Compatibility Normative	ETSI EN 301 489-1 ANSI CFR 47 Part 15
Quality Assurance Std.	ISO 9001
Weight	4.8 kg (10.58 lbs)
Output Pneumatic Connector	4 each 3/8" Compression Fittings

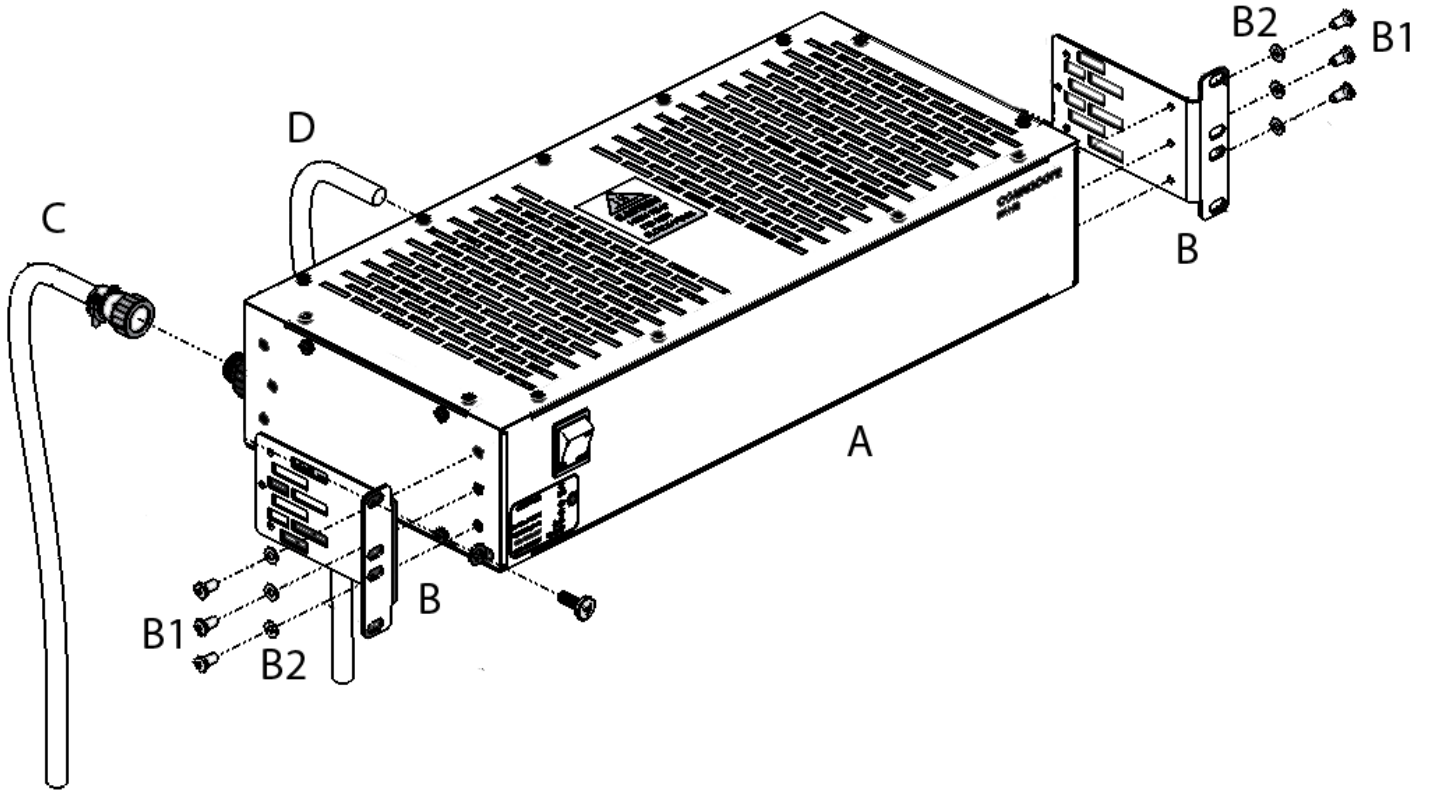

3.1 Supplied Equipment

Item	QTY	Description
A	1	HR150 Dehydrator
B	2	Mounting Brackets
B1	6	M4x10 PPH Screws, SST, Pass
B2	6	M4 Flat Washer, SST, Pass
C	1	Power Cable
D	30.5 m 100 ft	9.5 mm (3/8") Output Tubing

Additional Accessories ([sold separately](#))

HR150-KIT-ETSI
HR150-KIT-ACDC

HR150 ETSI N3 RACK BRACKETS KIT
HR150 AC TO 48 V DC POWER CONVERTER KIT

Section 4 Description

The HR150 dehydrator system is designed for continuous automatic operation. It is a heat regenerative desiccant dehydrator designed to operate on -48 / -60 V DC. The desiccant automatically regenerates by periodic heating and requires no scheduled maintenance. It will supply up to 150 liters per hour (5.3 scfh) of air with a dew point of better than -45°C (-49°F) at a nominal pressure of 3 kPa (0.44 psig).

The HR150 is designed for mount in a standard 19" equipment rack and has an option for ETSI N3 rack-mounting with adapter plates (sold separately). The HR150 requires 2 rack units to mount.

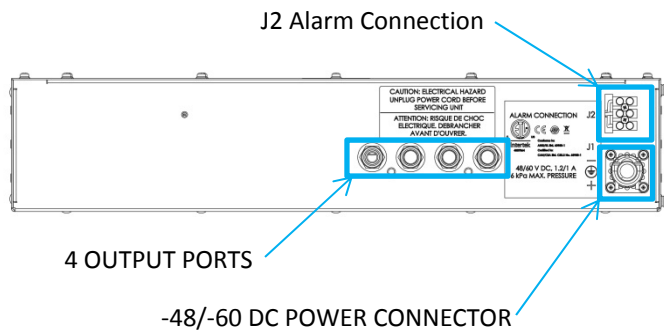

Dry air is supplied to the transmission lines by four independent outlets located on the rear of the chassis.

Ambient air is drawn through desiccant beds by two low power diaphragm compressors. The adsorbent material in the desiccant canisters removes moisture from the ambient air prior to passing it through the internal manifold where the system pressure and humidity level (optional) is monitored.

System pressure dictates demand and the HR150 will respond by changing the speed of the compressors allowing the dehydrator to function without pressure switches or regulators. This increases compressor life and overall unit reliability.

Section 5 Installation

5.1 Unpacking

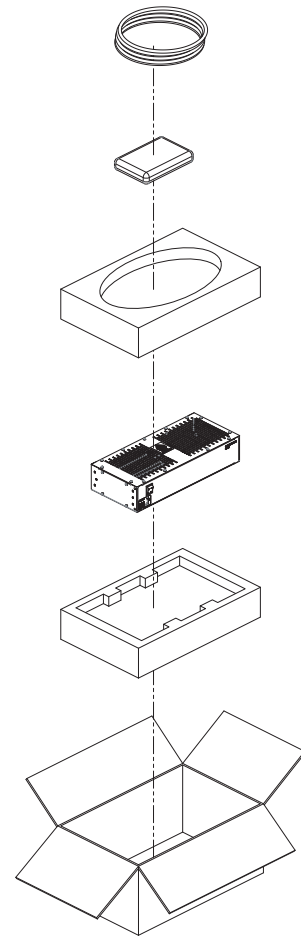

The HR150 includes all necessary brackets and electrical terminations to successfully install the unit in a site.

Installation of the HR150 requires the following tools:

- #1 and #2 Phillips head screw drivers
- Wire cutters and wire strippers for alarm terminations

5.2 Mounting

CAUTION: The HR150 utilizes heat to regenerate the drying canisters. Mount the HR150 at the top of the equipment rack. The heat created by the HR150 is dissipated out of the top and side of the dehydrator. DO NOT mount any equipment above the HR150.

5.2.1 19" Rack Mounting

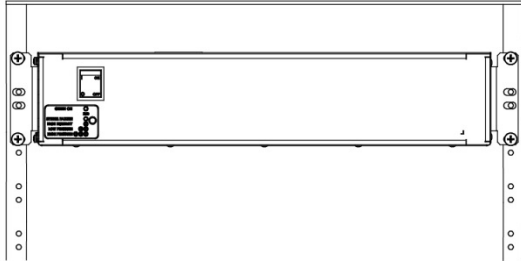

Attach the supplied rack brackets with the included screws to the front mounting holes for installation in a standard 19" equipment rack as illustrated below. The hardware necessary for mounting to the equipment rack is not included

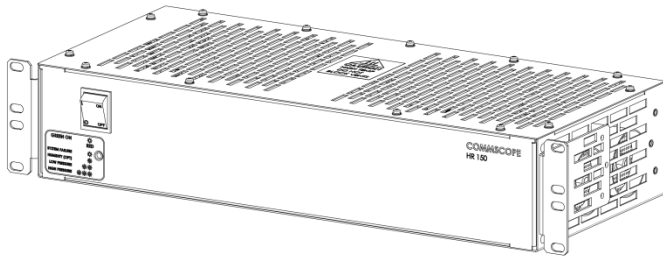

5.2.2 Wall Mounting

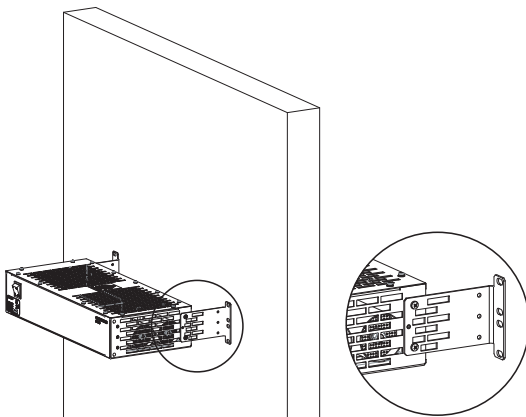

Install the standard 19" rack brackets on the rear of the chassis with the included screws as illustrated below. The brackets will provide

enough clearance for the tubing and electrical connections.

Secure the unit to the wall using appropriate fasteners for the wall material. The hardware for mounting to the wall is not included.

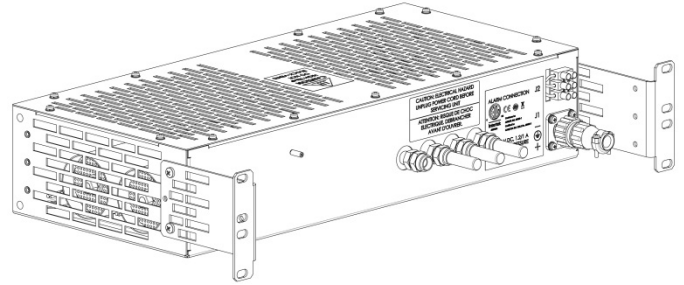

5.3 Electrical Connections

Caution: The ON/OFF switch on the front must be switched off prior to disconnecting the dehydrator from the power supply prior to servicing.

A protective earth terminal is available through the power connector J1 and is marked by the Earth Ground symbol.



Additionally, there is an external ground stud that can be used for additional electrical protection.

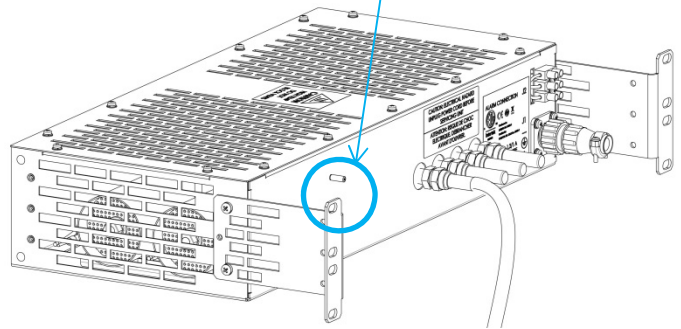

5.3.1 Power Connections

Verify that the power supply is the correct type and rated voltage prior to connecting the HR150. See power ratings label on rear side of the dehydrator.

The power cable comes pre-terminated for connection to J1 on the rear of the dehydrator. The HR150 incorporates reverse polarity protection. If the unit does not power up when connected to the DC supply, verify polarity and correct if necessary. The supply end of the

power cable is left un-terminated to accommodate any type of power supply.

If the proper DC power supply voltage is connected to the dehydrator and the power switch is turned on but the unit fails to operate, verify the polarity. If the polarity is incorrect, have it reversed and then re-connect to the dehydrator. The HR dehydrators are equipped with reverse polarity protection, but will not operate under reverse polarity.

Polarity for the power cable is:

- Red – Positive
- Black – Negative
- White - Ground

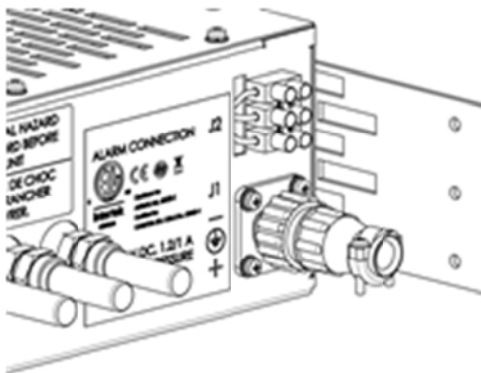

5.3.2 Alarm Connections

Alarm wiring will need to be provided by the customer at the installation site.

5.4 Pneumatic Connections

The HR150 has a quantity of four 9.5 mm (3/8 in) compression fittings located on the rear of the chassis. The dehydrator is shipped with one port open to ambient air. The other three ports are plugged with pressure caps in order to prevent air from escaping from these ports when not in use. In order to use these additional ports, simply remove the pressure caps.

5.4 Operation

Connect the included tubing to an open port on the rear of the unit. All unused ports must be plugged with pressure caps. Turn on the power switch located on the front face. The LED will illuminate.

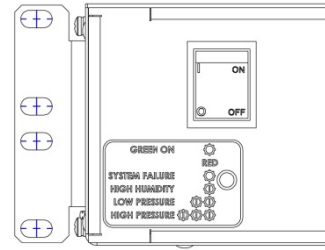

The first compressor will start and air will begin flowing to the transmission line(s).

If this is a new installation, the transmission lines must be purged by creating a small leak at the far end of the transmission lines and allowing the dehydrator to pump dry air through them.

A minimum of three air volume exchanges is required. If the installation is located in a very humid area, up to twelve air exchanges may be necessary to properly purge the transmission line. The time, in hours, necessary to exchange the air one time is based on the total air volume (V) of the waveguide and antenna system.

Purging time (hours) = (3 x V) / 150, where V is line volume in liters

At the conclusion of the purging cycle, close the far end of the transmission lines.

5.6 Alarms

The HR150 is equipped with an LED on the front panel for a visual indication of alarm conditions. A green LED indicates all is well with the dehydrator. A solid or blinking amber LED indicates a problem with the dehydrator.

HR150 SERIES DEHYDRATOR USER MANUAL

Blinks	Alarm	Description
Solid Amber	System Failure	Indicates a failure of the controller. Replacement will be necessary.
1	High Humidity (optional)	Indicates output air is above 10% RH. This can be caused by long storage periods and should clear in the first 24 hours of operation.
2	Low Pressure	Indicates a system pressure lower than alarm threshold.
3	High Pressure	Indicates a system pressure higher than alarm threshold.

Section 6 Corrective Maintenance and Spare Parts

The HR150 is designed to be maintenance free. If you experience any issues with the HR150, please contact CommScope. See Section 8 for additional information.

If multiple alarms exist at the same time, they will blink in sequence with approximately two seconds between.

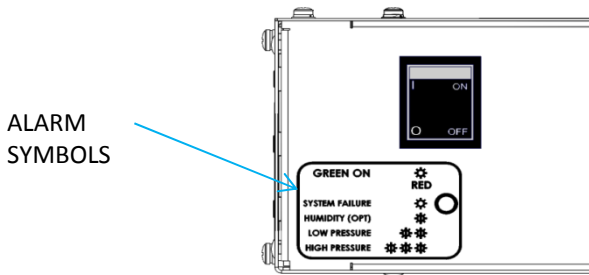

Front of Chassis

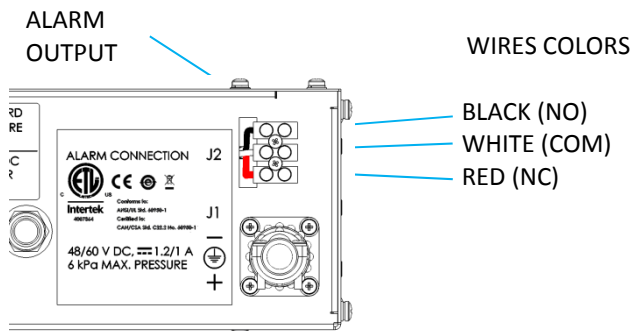

Rear of Chassis

Section 7 Outline

Outline without mounting brackets

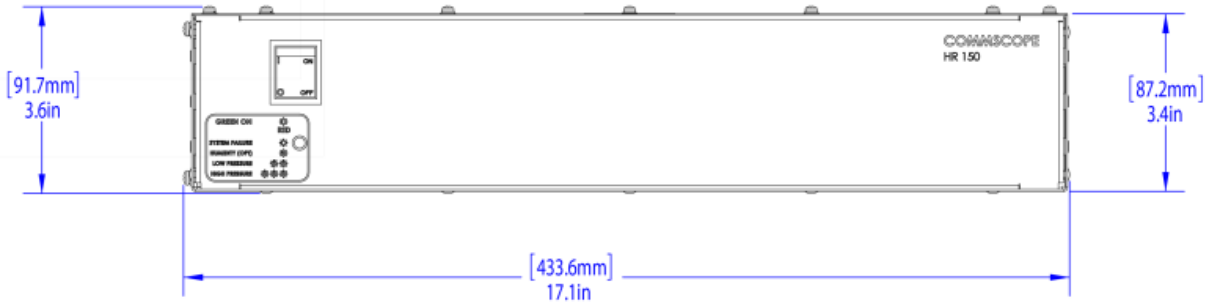

Outline for 19" rack and wall mounting

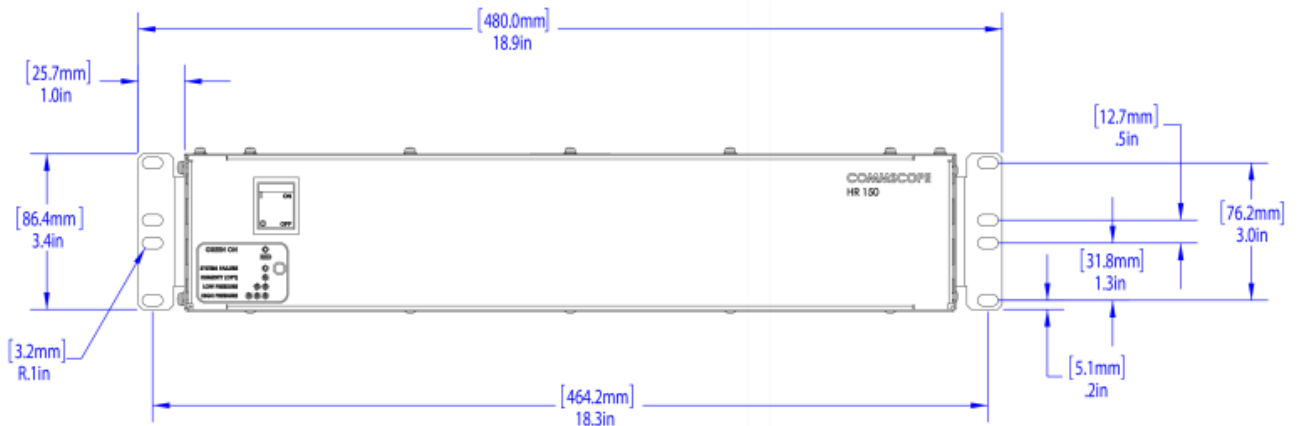

Outline side view

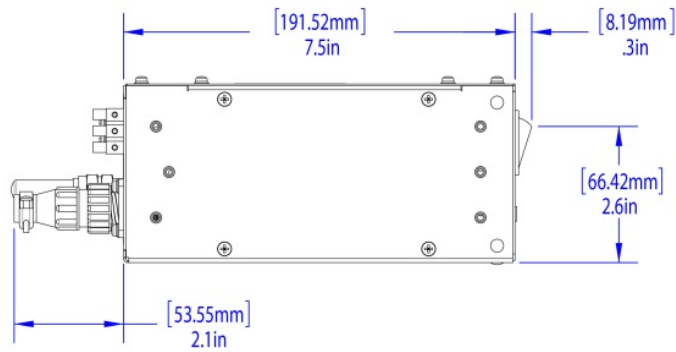

Outline side view wall mounting

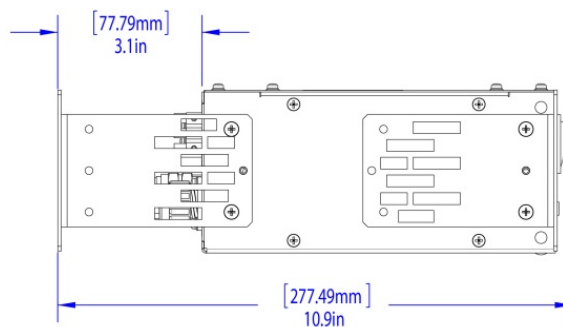

Section 8 Customer Service

8.0 Introduction

CommScope provides in-warranty and out-of-warranty repairs as well as dehydrator and compressor overhauls from several Repair Centers. Coordination of these services is provided through the nearest Sales Office or Customer Service Center. The Center is also prepared to help you with the following:

- Technical Assistance
- Troubleshooting
- Repairs
- Loaner Units
- Spare Parts
- Installation Materials
- System Accessories

8.1 In Case of Trouble

The first step you should take if trouble develops using a dehydrator is to read the operators manual and follow the trouble shooting procedures given in it.

Symptom	Potential Solution
Pump Not Running	Cycle power of the unit
	Verify pumps are connected to PCB
	Open output port and verify pump speed increases
Low Pressure Alarm	Unused output port not capped
	Transmission line open/leaking
	Internal tubing disconnected / leaking
High Pressure Alarm	Very small system volume; allow unit pressure to settle over 20 minutes
High Humidity Alarm	Leaking desiccant canister end plate
	Insufficient system purge
Unit Will Not Power Up	DC Power polarity may be reversed
	Loose or disconnected wire inside of the unit

If the steps in the manual do not identify and remedy the problem, then contact a CommScope Customer Service Center for 24-hour telephone assistance. Record the Model Number (e.g. HR150) and Serial Number from the product label, as you will be asked for these when you call. Two main locations are currently available to help:



From North America

- Telephone: 1-800-255-1479
- Fax (U.S.A.): 1-800-349-5444

International

- Telephone: +1-779-435-6500
- Fax Number: +1-779-435-8579

Web Access

- Internet: www.commscope.com
- email: #prc@commscope.com

8.2 Initial Steps by CommScope

When your call or fax communication is received, the CommScope staff will work with you to pinpoint the possible cause of trouble. If the pressurization equipment is suspect, they will:

- ask for your unit Model Number and Serial Number
- check the warranty status of the unit
- advise the availability of a loaner unit
- provide an estimate of the cost for inspection and repairs, if the unit is out-of-warranty
- fax a Return Material Authorization Sheet to you

8.3 Repair Center Process

A method of Payment must be provided prior to issuing of RMA regardless of warranty status.

IN-WARRANTY REPAIR: This CommScope pressurization product carries a warranty of one year. Warranty details are available on our web page. If your unit falls within its warranty period, inspection and repairs will be performed at no charge and the unit will be promptly returned to you. If a warranty unit is deemed no problem found an inspection fee and freight will be charged to the customer.

OUT-OF-WARRANTY REPAIR: We will inform you with the cost of repair and obtain your approval to proceed with repairs or, if you elect not to have the unit repaired, your instructions on disposition of your unit. When repairs are complete, we will return your unit and invoice you for the inspection charge, materials used for the repair and labor applied to complete the repair. If you elected not to repair the unit, we

will invoice you for the inspection and freight charge if unit is to be returned.

LOANER UNITS: Loaner units may be available from the repair center to maintain your system while repairs are being performed. If you feel you need a loaner, please contact us at one of the contact numbers. If a loaner unit is available, a P.O. for the full value of the unit must be issued prior to shipment. Also contact us when the loaner is ready to be returned so that we can issue a NEW RMA number to identify your return and create the appropriate credit to your account. Damages to loaner will be deducted from the P.O.

PACKING INSTRUCTIONS: Pack your unit securely for shipment to the Repair Center. If you received a loaner unit, we suggest you use the box and packing materials to return your unit. Otherwise we have factory packing materials available for a nominal fee. Enclose a completed copy of this form inside the box and clearly mark your Company Name and RMA: XXXXXXX on outside of the box. Address the box to the following Ship-To Address:

CommScope Pressurization Service Center
RMA# XXXXXXX
11312 S. PIPELINE RD.
EULESS, TX. 76040-6629

Please note, Units received with Biological/animal contamination will be returned unrepared or scrapped after notification and you will be invoiced for inspection and freight.

CONTACT NUMBERS: If you have any questions about the repair process or status of your unit, please contact us directly through one of the following methods – Telephone (below)

TEL: 817-864-4150
817-864-4155

FAX: 817-864-4179

8.4 RoHS Inquiries

For inquiries on RoHS please contact the following:

CommScope Inc.
Corke Abbey, Bray Co.,
Dublin, Ireland
Attn: Legal Department

