

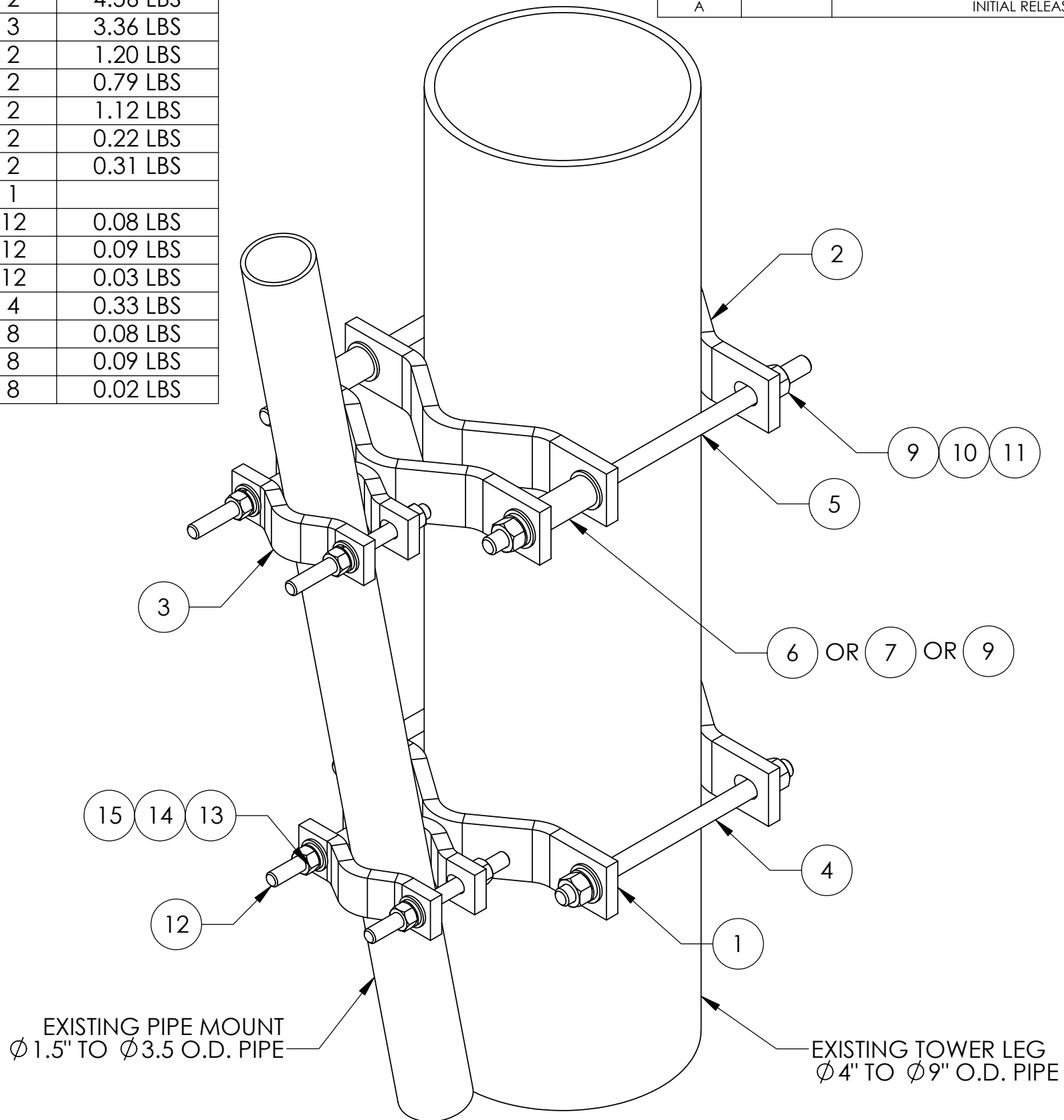

ITEM	PART NO.	DESCRIPTION	QTY.	WEIGHT
1	MSA	MEDIUM TO SMALL PIPE ADAPTER	2	4.56 LBS
2	MCP10	MEDIUM CLAMP HALF	3	3.36 LBS
3	SCP10	SMALL DISH CLAMP HALF	2	1.20 LBS
4	MT-381-10	5/8" X 10" THREADED ROD	2	0.79 LBS
5	MT-382-14	5/8" X 14" THREADED ROD	2	1.12 LBS
6	OS234	3/4" X 2-1/4" OFFSET SLEEVE	2	0.22 LBS
7	OS334	3/4" X 3-1/4" OFFSET SLEEVE	2	0.31 LBS
8	HB5812	HARDWARE KIT (ITEMS 9-11)	1	
9	GN05A	5/8" GALV HEX NUT (A325)	12	0.08 LBS
10	GWL-05	5/8" GALV LOCK WASHER	12	0.09 LBS
11	GWF05A	5/8" GALV FLAT WASHER (A325)	12	0.03 LBS
12	MT-379-6	1/2" X 6" GALV THREADED ROD	4	0.33 LBS
13	GN04A	1/2" GALV HEX NUT (A325)	8	0.08 LBS
14	GWL-04	1/2" GALV LOCK WASHER	8	0.09 LBS
15	GWF04A	1/2" GALV FLAT WASHER (A325)	8	0.02 LBS

REVISIONS				
REV.	ZONE	DESCRIPTION	BY	DATE
A		INITIAL RELEASE	JTS	04/06/01



NOTE:
 1. INCLUDED SLEEVES (ITEMS 6 & 7) & NUT (ITEM 9) TO BE INSERTED IF REQUIRED FOR TOWER TAPER.
 2. OFFSET SLEEVES MAY BE CUT FOR DIFFERENT TAPER.

<small>These drawings and specifications are the proprietary property of ANDREW CORPORATION and may be used only for the specific purpose authorized in writing by Andrew Corporation.</small> <small>ALL DIMENSIONS ARE IN INCHES U.O.S.</small> <small>TOLERANCES UNLESS OTHERWISE SPECIFIED:</small> .X = ± .06 ANGLES ±2° .XX = ± .03 FRACTIONS ±1/32 .XXX = ± .010 <small>REMOVE BURRS AND BREAK EDGES .005</small> DO NOT SCALE THIS PRINT	<small>DRAWN BY:</small> ACG	<small>SHEET:</small> 1 of 1	<small>PART NUMBER:</small> MS-100-SSH
	<small>CHECKED BY:</small> TP	<small>SCALE:</small> NTS	<small>DESCRIPTION:</small> TAPERED PIPE ADAPTER CLAMP SET
	<small>DATE:</small> 10/17/05	<small>MATERIAL:</small> A36	<small>DRAWING TYPE:</small> ASSEMBLY DRAWING
	<small>REVISION:</small> A	<small>FINISH:</small> GALV A123 <small>WEIGHT:</small> 30.05 LBS	 ORLAND PARK, IL. 60462 U.S.A.