

## Closure

### Contents

<b>1 Introduction</b>	<b>5 Installation of the OPGW cable in the closure</b>
<b>2 General</b>	<b>6 Installation of plastic sheathed FO cable</b>
2.1 Kit content	6.1 Closure preparation
2.2 Tools	6.2 Cable preparation
2.3 Capacity	6.3 Cable sealing
<b>3 Preparation of the closure</b>	<b>7 Organizing fibers in the splicing trays</b>
<b>4 Installation of optical grounding wires (OPGW)</b>	<b>8 Dome installation and closing the closure</b>
4.1 Cable preparation	<b>9 Adjusting the pole bracket for installation on the pole or tower</b>
4.2 Installation of the cable clamp cylinders	<b>10 Installation of metal protection cover (optional)</b>
4.3 Installation of the transportation tubes	
4.4 Installation of the multiple tube sealing kit	
4.5 Installation of the built up tubes	

## 1 Introduction

The FOSC-OPGW is a single-ended closure system specially developed for use on the optical grounding wires of overhead electrical power lines. The closure is suitable for use above ground; it can be attached to high voltage towers, poles, walls or other support structures. One model can be used for track and spur joint applications.

The FOSC-OPGW closure system has the following functions and features.

It permits the termination and sealing of

- 2 OPGW cables
- 2 ADSS or conventional buried fiber optic cables
- Single-ended design with valve
- A galvanized steel mounting frame holds the thermoplastic dome and base and the OPGW cable clamps
- A pole mounting kit is included which allows the closure to be mounted on a traverse strut of a high voltage tower without the need to drill holes in the metal construction
- A stainless steel shot-gun protection enclosure is optionally available.
- Cable seals are manufactured from heat-shrinkable material.
- Internal storage utilises FOSC splice trays which are hinged for access to any splice without disturbing other trays.

Follow all local safety regulations related to optical fiber plant elements.

## 2 General

### 2.1 Kit content (for the installation of 2 cables)

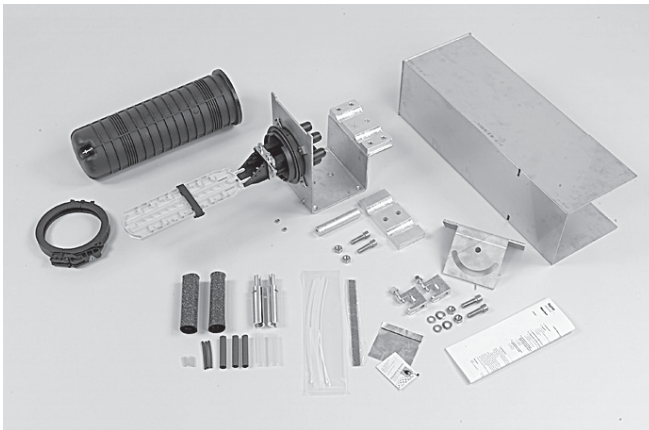

- FOSC closure dome with valve
- FOSC base preinstalled on metal base with pre-installed tray(s)
- Dome to base closing clamp
- O-ring
- 1 OPGW cable clamp (can hold 2 cables)
- 1 metal cable plug in case one OPGW cable is used
- Adjustable pole mounting bracket (with C clamps)
- Screws, nuts and washers for bracket installation
- Metal outer protection cap (optional)
- Silica gel
- Abrasive strip
- Cleaning tissue
- 2 cable sealing kits
- Sealing kit for use with multiple tubes cable
- Tube building up kit
- A set transportation tubes
- Installation instruction

### 2.2 Tools

Besides the standard tools necessary to install fiber optic closures, following tools are recommended :

- FACC-TUBE-CUTTER-01 to cut FOPT
- FACC-TUBE-STRIPPER-02 to strip non metallic loose tube
- FACC-HEAT-GUN-220V to shrink cable seals
- OPGW tube cutter to cut OPGW tube to length
- Allen key nr 10 mm for securing and adjusting the closure bracket on the pole to terminate the OPGW cable in the closure bracket

### 2.3 Capacity

Cable capacity is 4 cables (OPGW and/or FO cable)

	Diameter (mm)	
	Min.	Max.
OPGW	9	18
FO-cable	5	19

The fiber capacity depends upon the type of cable used and must therefore be determined on a case-by-case basis.

Maximum quantity of splices that can be stored is 72 for A-size and 144 for B-size.

## 3 Preparation of the closure

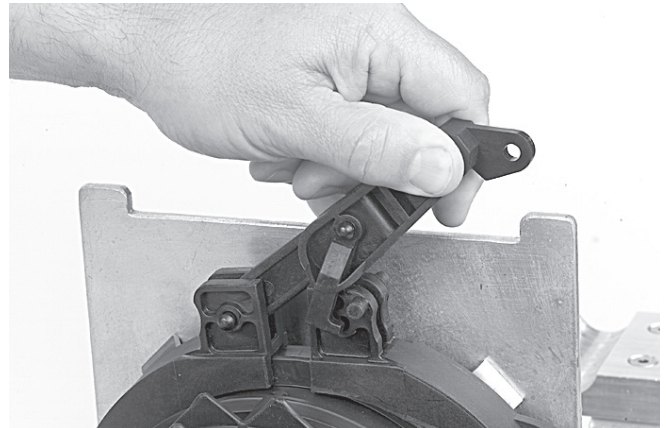

3.1 Open the mechanical dome to base clamp and remove the dome and O-ring.

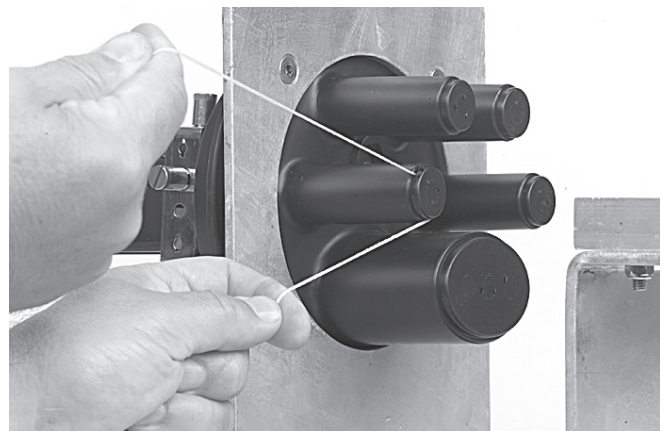

3.2 Position the closure on a mounting table and open by use of a cutting wire the cable ports that will be occupied.

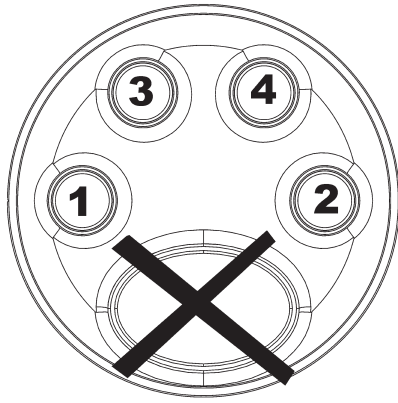

3.3 Port 1 & 2 can be used for OPGW cables only and Port 3 & 4 should be used for standard polymer fiber optic cables.

**Note:** the oval outlet will not be used in the FOSC OPGW closure.

## 4 Preparation of optical grounding wires (OPGW)

### 4.1 Cable preparation

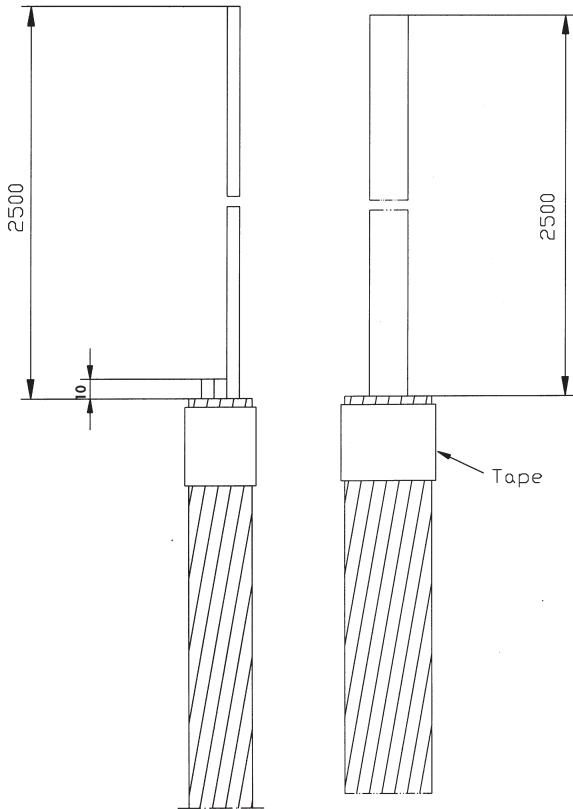

**OPGW with  
1 up to 3 metal  
loose tubes**

**OPGW with  
inner jacket and  
plastic loose  
tubes**

4.1.1 Straighten the cable over a minimum length of 2.5 meter.

4.1.2 Mark the cable at 2.5 meter and wrap tape around the cable at the marking point.

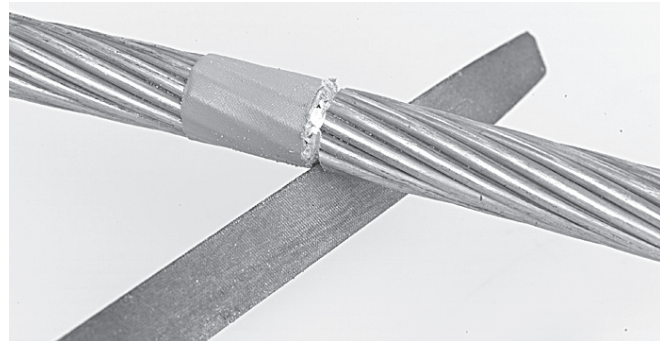

4.1.3 Make a circumferential incision in the cable at the marking point by using a saw or triangle file.

4.1.4 Remove the aluminum cable strands starting from the cable end.

4.1.5 Break the strands and remove the sharp edges with a file.

**Note:** in case of a cable with central core tube continue with the cable clamp cylinder installation as described from point # 4.2.

4.1.6 Separate the metal loose tubes from the steel strands.

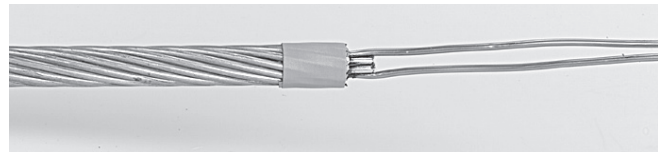

4.1.7 Remove the central steel strands according to above drawing leaving 10 mm from the outer strands. Remove sharp edges with a file. Attention: put a metal plate between metal loose tubes and steel strands during removal. Check metal loose tubes for damage after removal of steel strands and filing.

### 4.2 Installation of a cable clamp cylinder

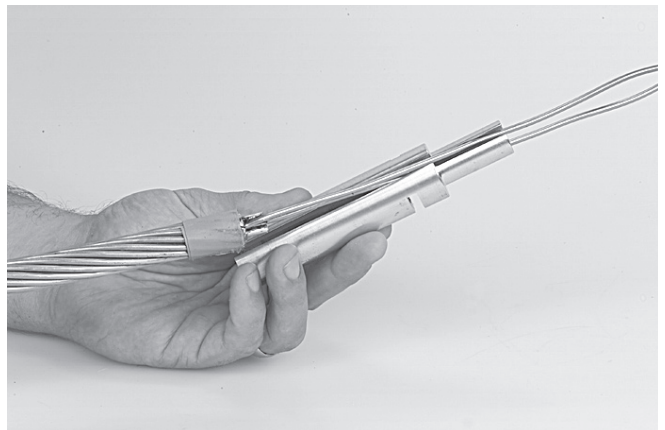

4.2.1 Slide the metal loose tubes or the central tube through the slit of the cable clamp cylinder.

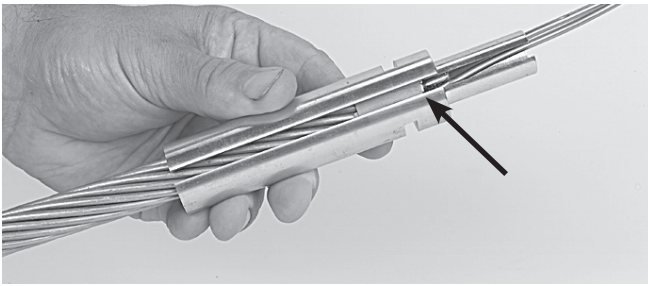

4.2.2 Position the cable clamp cylinder completely over the cable strings till the strings are butted in the end of the cylinder (see picture).

### 4.3 installation of the transportation tubes

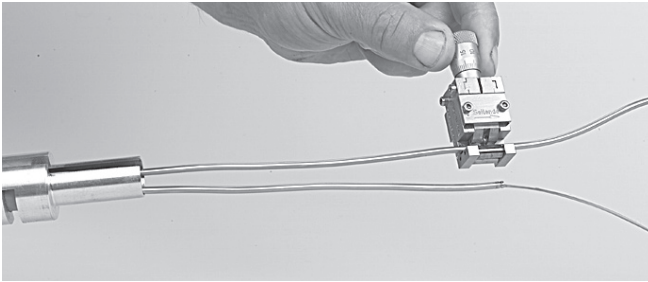

4.3.1 Make a circular cut in the metal loose tubes at 150 mm from the cable cylinder clamp end.

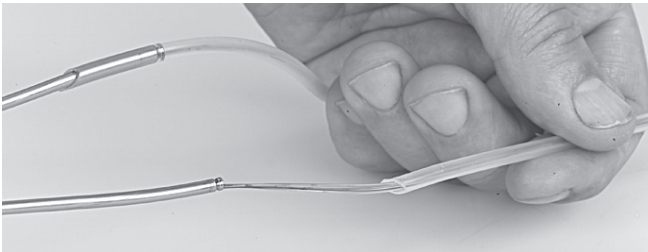

4.3.2 Feed the fibers through a transportation tube depending on the diameter of the metal loose tubes use the appropriate size of tube. Slide the tube  $\pm$  50 mm over the metal loose tube.

### 4.4 Installation of the multiple tube sealing kit

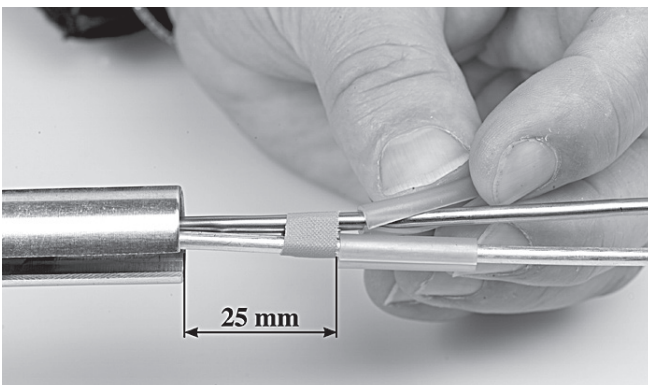

4.4.1 Install the adhesive slit tube over each of the metal cleaned loose tubes and position with some small tape the sealant tube at 25 mm from the cable cylinder clamp end.

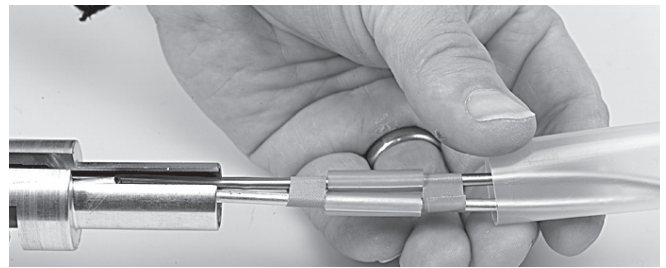

4.4.2 Slide the transparent blocking tube over all the metal loose tubes and the adhesive slit tubes up till the cable cylinder clamp.

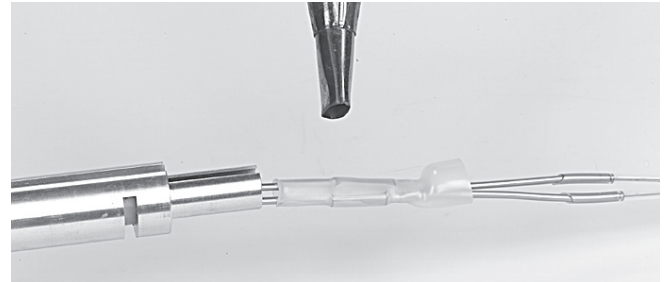

4.4.3 Shrink down the transparent blocking tube with a hot air gun , continue heating till the adhesive slit tubes are melted and seal between the metal loose tubes.

### 4.5 Installation of the built up tubes

4.5.1 Table of built up (dimensions in mm)

Diam. tubes	built up 1st sleeve	built up 2nd sleeve	built up 3rd sleeve
1.7	3.5	4.5	6.5
3.1	4.3	6.3	
3.6	4.7	6.4	

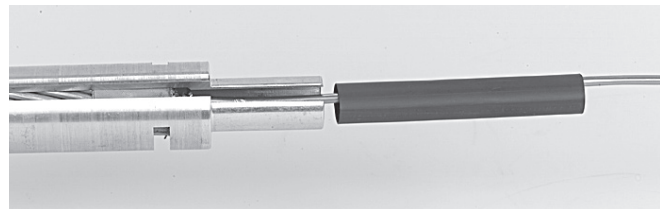

4.5.2 In case of a single metal loose tube position a small built up tube over the cleaned metal loose tube up till the end of the cable cylinder clamp.

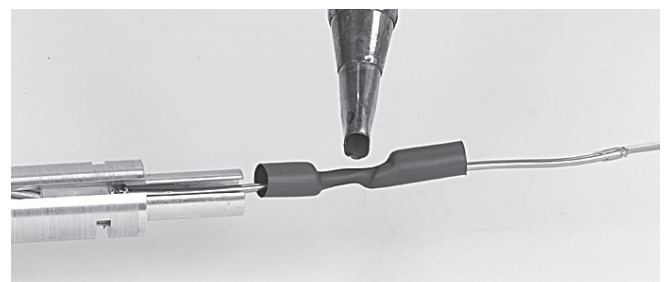

4.5.3 Shrink down the built up tube with a hot air gun, start heating from the middle of the tubing towards the ends.

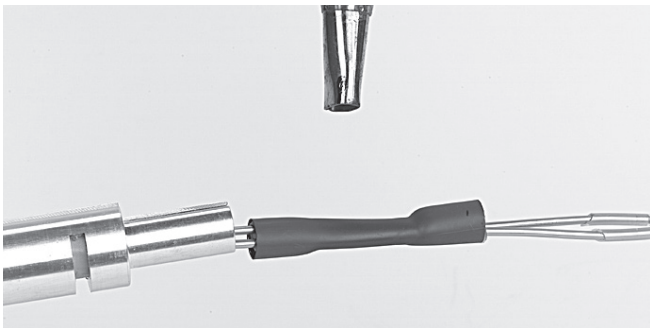

4.5.4 In case there are multiple loose tubes, position a built up tube over the cleaned transparent sealing tube up till the cable cylinder clamp and heat the built up tube starting from the middle of the tubing.



4.5.5 When the loose tube diameter including the built up tube or the transparent sealing tube is smaller than 5 mm continue installing extra heat shrinkable sleeves till the correct diameter is reached (see table # 4.5.1.). Always clean previous installed heatshrink tube.

## 5 Installation of OPGW cable in closure



5.1 Slide the cable to base seal over the cable end and the cable cylinder clamp. The arrow on the sleeve should point towards the cable end and closure.

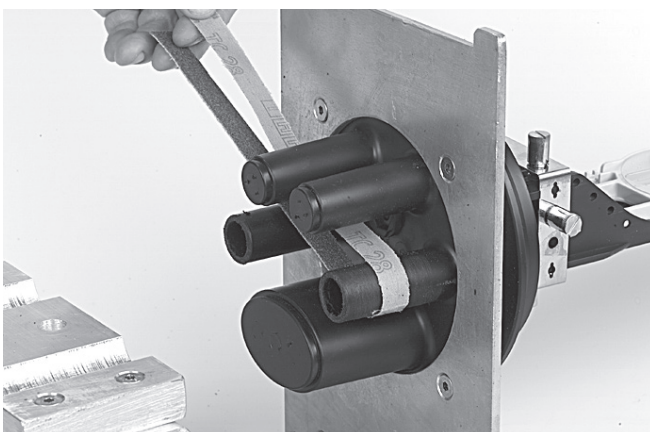

5.2 Clean and abrade the cable cylinder clamp and the cable port of the closure with the supplied material.

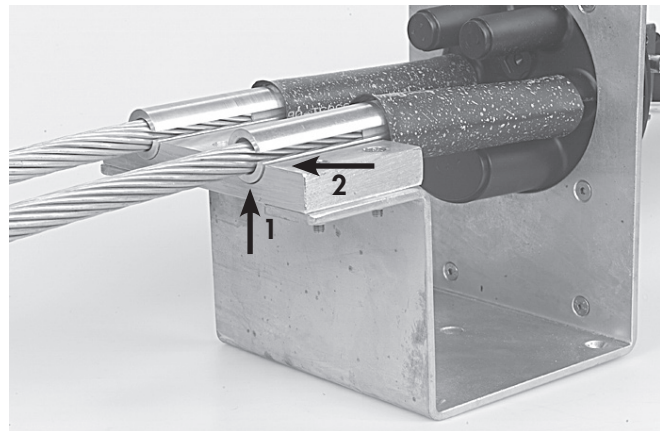

5.3 Feed the cables through the cable ports and position the heat shrink sleeve onto the cable ports. Position the cable cylinder clamp ends to the cable support so that they are in the same plane as the support end (1), and the longitudinal slits are parallel to the support (2).

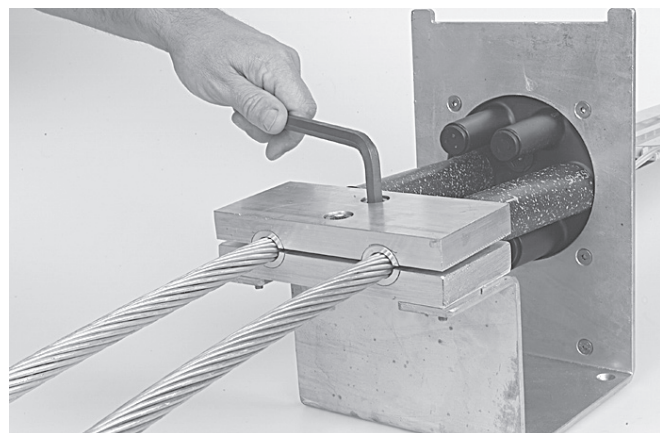

5.4 Install the second half of the cable clamp and tighten bolts with an Allan key .

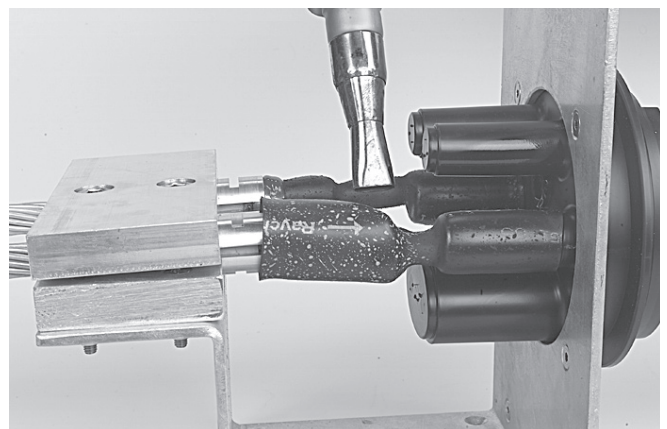

5.5 Shrink the heat shrink cable seals to the cable port and cable cylinder clamp ,starting from the closure cable port towards the cable. Continue heating till all the green thermo indicating paint has changed to black.

## 6 Installation of plastic sheathed FO cable

The following steps of the installation instruction are based on the standard FOSC installation with the FOSC installation bracket, which is not required.

### 6.1 Closure preparation

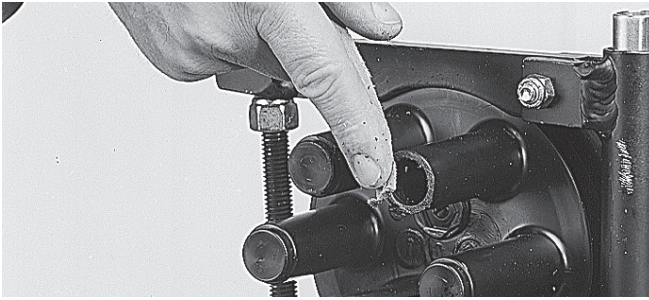

6.1.1 Open the port for cable entry by cutting the port at the ridge with the cutting wire. Deburr the inner edge of the port opening with abrasive strip.



6.1.2 Remove any dirt, mud or other contaminants from the cable sheath for approximately 2 meters with a clean cloth. Take the cable seal sleeve from the kit FOSC-B/D-CSEAL-1-NT and slide it over the cable. The non-coated edge of the sleeve and the arrows should be pointed to the base of the closure.

### 6.2 Cable preparation

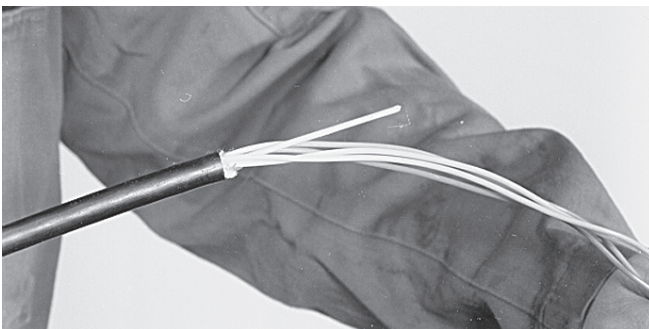

6.2.1 Remove the cable sheath (and shield if present) over a length as required by locally approved practice (e.g. 1,2 meters). 1.1 m is the maximum allowed length if the ribbon (6R4) or high capacity trays (S24) are used. Clean filling compound from fiber tubes and cut central strength member at a distance of 75 mm from outer jacket.

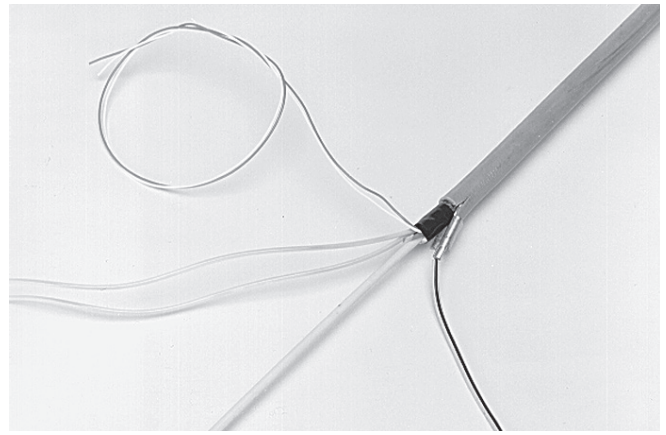

6.2.2 If a shield continuity is required, cut cable sheath axially for 25 mm from cable ring cut. Crimp shield clip on cable sheath with pair of pliers. Protect the clip with self adhering tape.

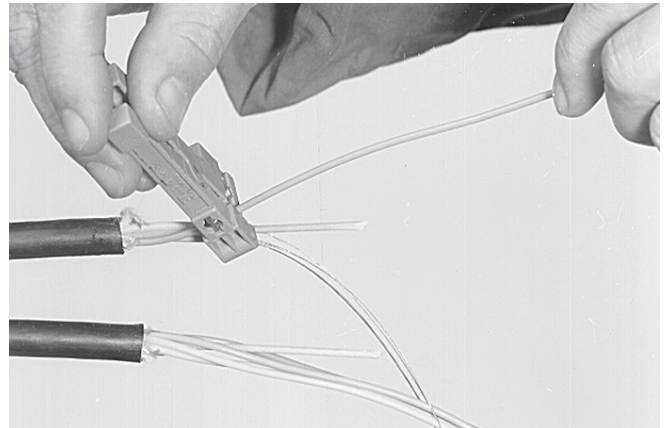

6.2.3 Cut the loose tube, at a distance of 35 mm from the cable ring cut and remove and degrease fiber bundle. Select a transportation tube which fits over the loose tube. Slip transportation tube over fibers and the loose tube.

**Note:** for slotted core cable: use an appropriate kit which converts the slotted cable construction into a loose tube construction.

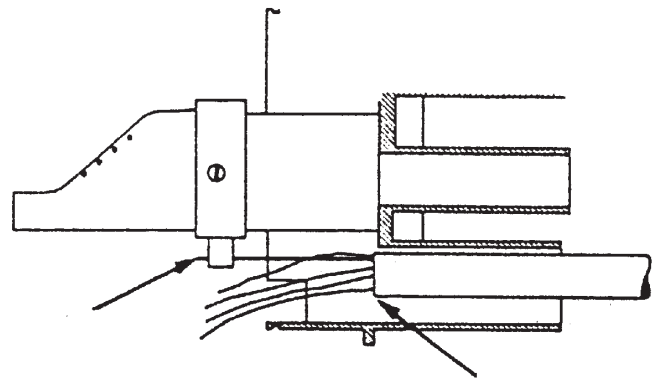

6.2.4 Align cable ring cuts with edge of base.

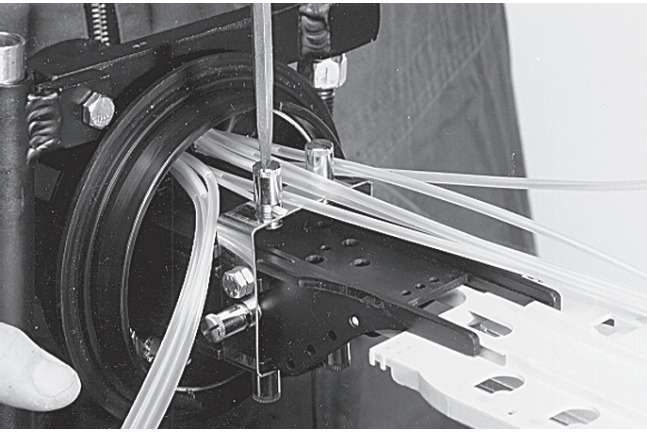

6.2.5 Slide strength members into clamps and tighten. Cut away the excess length of strength member.

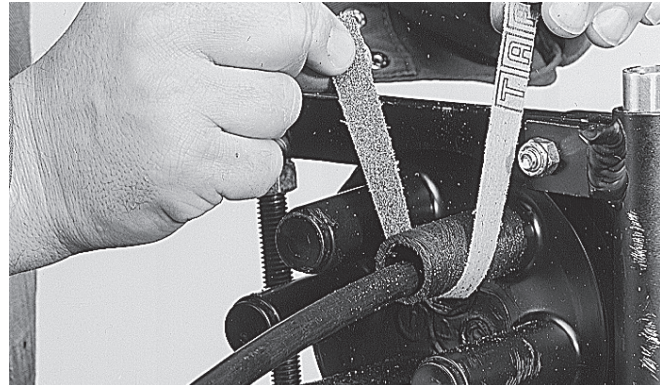

6.3.2 Abrade port and cable sheath circumferentially on the cleaned area with the abrasive strip. Remove any abraded material with a clean cloth.

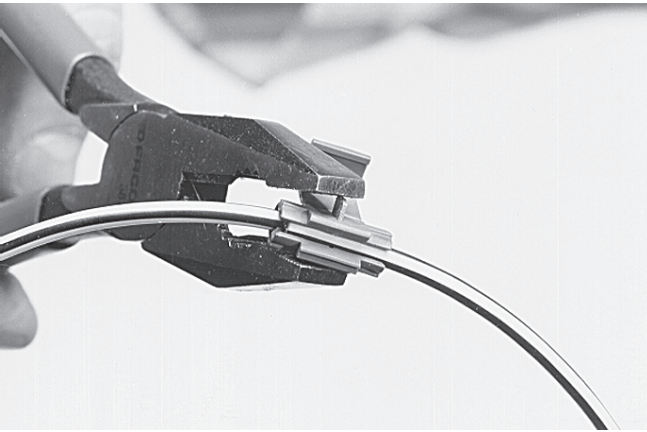

6.2.6 If required, connect shield continuity wire of both cables with shield continuity clip. Talk pairs, if present, will be connected together according to the local procedures.

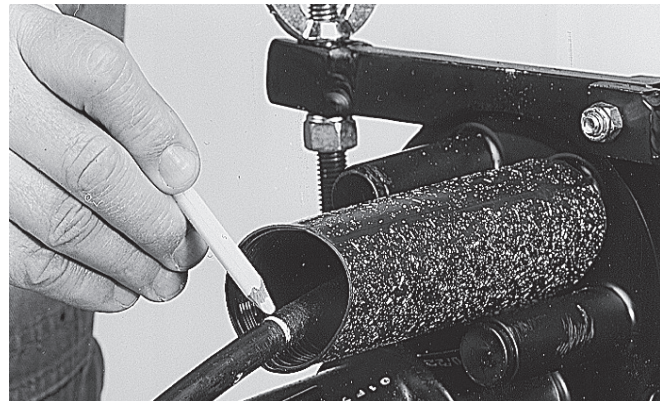

6.3.3 Place cable seal over the drop outlet of FOOSC base. When cable seal butts against the base, mark the sleeve length on cable sheath.

### 6.3 Cable sealing

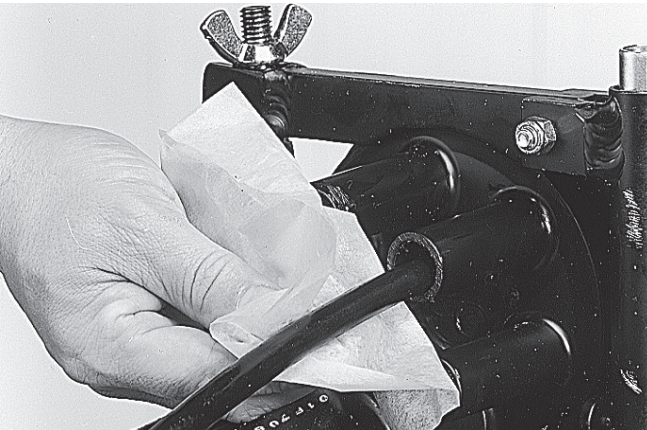

6.3.1 Thoroughly clean port and cable sheath with the cleaning tissue over a distance of 100 mm from the edge of the port.

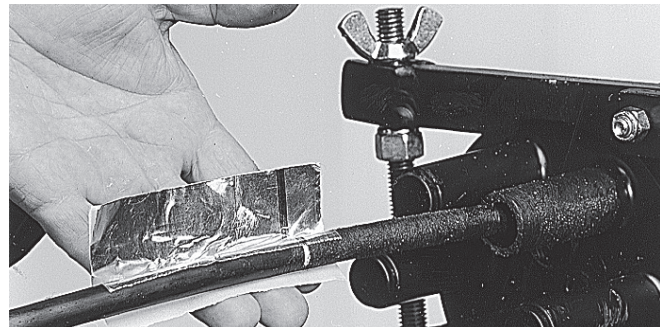

6.3.4 Match the blue line of the aluminium cable protection foil with the marks on the cables. Wrap the aluminium cable protection foil around cable.

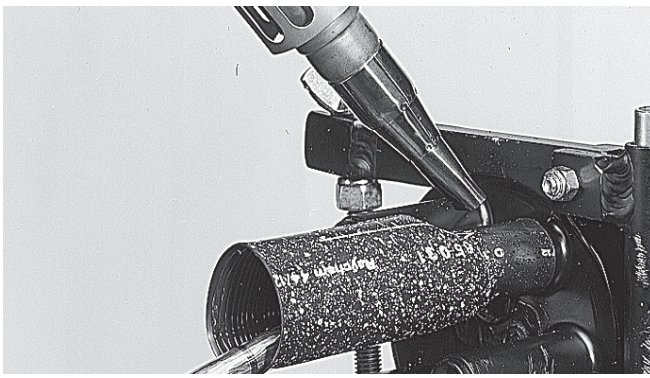

6.3.5 Slide the cable seal over the port. Shrink the cable sleeve on the base side with the recommended hot air gun device. Use the reflector to ensure heat distribution around the outlet. Shrink sleeve until the green thermo-indicating paint is converted to black.

**Note:** setting of the thermogun: FACC-HEAT-GUN-220V in position 10. Minimum hot air temperature should be 350°C.

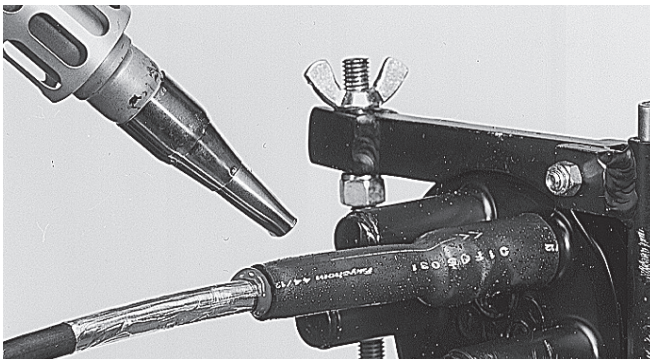

6.3.6 Shrink down the end of the sleeve on the cable side. Heat till the sleeve shrinks down onto the cable and the green thermoindicating paint is converted to black. A ring of red adhesive should be visible at the cable on the end of the sleeve.



6.3.7 Wait until the sleeve is cool to the touch before moving the cables.

## 7 Organising fibers in the splicing trays

### 7.1 If a FOSC-B-TRAY-S12-1 is use Tray for up to 12 splices

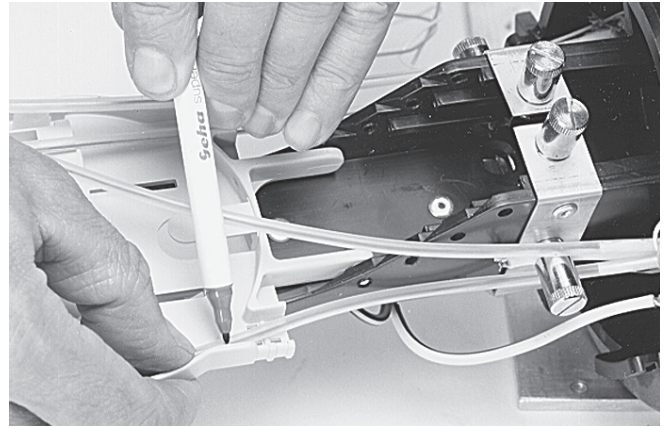

7.1.1 Each splice tray accommodates 12 fiber splices maximum and each side of the tray holds a maximum of 4 big transportation tubes or 6 small transportation tubes. Position the transportation tubes on bottom tray and align the tubes along the tray. Place a mark on each tube on tray side at 15 mm from tray edge.

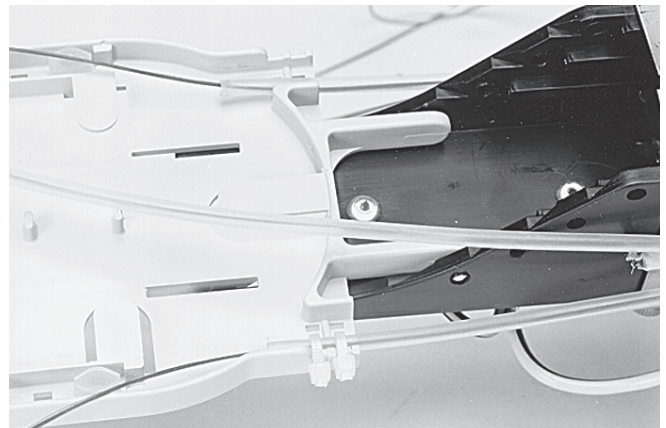

7.1.2 Carefully cut the transportation tubes at the mark and secure to splice tray with two tie wraps. The transportation tube may not be in contact with fibers stored in the organizer. Other tubes should be laid out of the way of the bottom tray. Alternatively, additional trays may be installed to store the fibers (see section 7.5). Cut the transportation tubes in the organiser/tray. Always place transparent cover over tray.

7.1.3 Position the FOSC-400B2&B4 by the splicing machine in a convenient location, and secure the closure.

7.1.4 Slide the heat-shrinkable splice protection over one fiber and fuse fibers according to local recommendations and procedures. After the fusion splice is made, install the heat-shrinkable splice protection (e.g. SMOUV) with appropriate heating source. Allow the splice protection to cool down to ambient temperature.



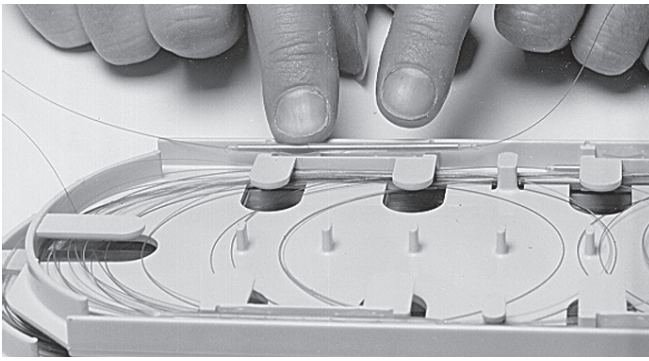

7.1.5 After each splice is made, the splice should be stored in the splice holder. Do not deform the splice protector during insertion. The fiber slack should be coiled into the tray.

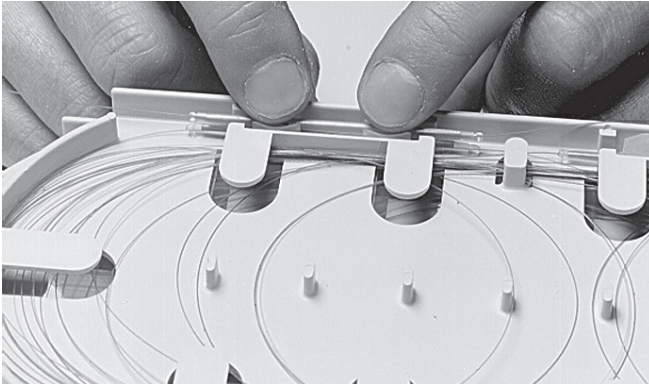

7.1.6 For 12 fiber capacity tray, two fusion protection sleeves should be installed on top of one another in one splice holder.



7.1.7 Upon completion of splicing, install the clear protective cover on the tray. Secure cover by installing the hook and loop fastener strip around the trays and cover.

**7.2 If a FOSC-B-TRAY-S24-1 is used.  
Tray for up to 24 short fusion splice protectors**

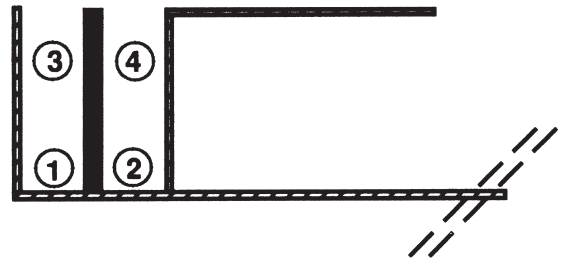

7.2.1 The tray organiser has 6 positions to store splice protectors. Each position can hold maximum 4 fusion splice protectors of type SMOUV 1120-02 (length = 45 mm, installed outer diameter is 2,4 mm) or equivalent. Each side of the tray holds a maximum of 4 big or 6 small transportation tubes, see 7.1.1. Make sure the cable has been stripped to a maximum length of 1.1 m.

7.2.2 After each splice is made, the splice should be stored as indicated on the drawing (see 7.2.1.). First protector in position 1, the second in position 2. Continue for other fibers. Fiber n°5 will be in position 1 of next location. Coil the excess length of fiber each time you have positioned the splice protector.

**7.3 If a FOSC-B-TRAY-6R4-1 is used.  
Tray for up to 6 ribbons of 4 fibers**

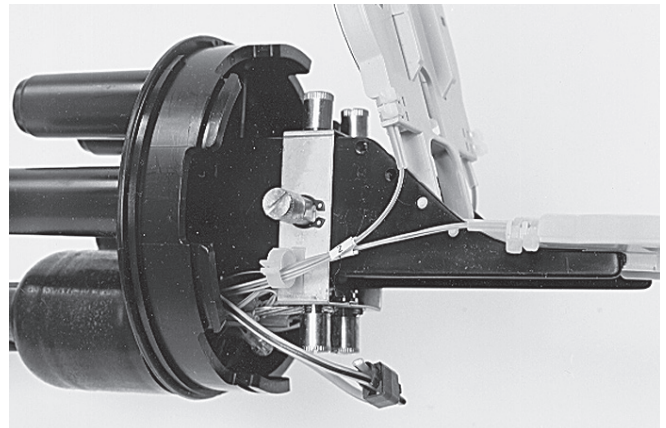

7.3.1 The tray organiser has 6 locations in which spliced ribbon fiber (max. 4 fibers per ribbon) can be held. The base of the ribbon closure has ribbon fiber guiding clips which allow the ribbon to be directed to the organizer tray without touching the brackets of the strength member. Use the appropriate splice protection for ribbon construction (length = 40 mm) e.g. fiber protection sleeve FPS-5 Sumitomo, Fujikura FP-5 or equivalent. Make sure the ribbon cable has been stripped over a maximum length of 1.1 m. Guide the ribbon fibers through the fiber guiding clips and close the clips. Make sure the ribbons are not squeezed off while closing the clips.

7.3.2 Group max. 6 ribbons per tray and slide the transportation tube over the ribbons (max. 3 ribbons/tube). Identify the group of fibers per cable.

7.3.3 Carefully secure the transportation tube to splice tray and secure with two tie-wraps per tray entrance. Temporarily store the ribbons into the tray. Proceed for all groups of ribbons.

7.3.4 Use appropriate fusion splice protector and slide it over one ribbon fiber. Splice and install splice protector according to the local procedure.



7.3.5 After cooling, the splice protector should be stored in the splice holder. The ribbon slack should be coiled into the tray. To minimize the torsion of the ribbon after coiling it into the tray, it is recommended to precoil the ribbon before splicing. Two complete turns is the maximum.

#### 7.4 Intertray jumpers

7.4.1 When it is necessary to splice fibers that are placed on different splice organizer trays an intertray jumper may be used to route one or more fibers to the desired tray.

7.4.2 Secure one end of intertray jumper tube to the splice tray and secure with two tie-wraps.

7.4.3 Define the length of intertray jumper tube and mark. Proceed in the same way as per point 7.

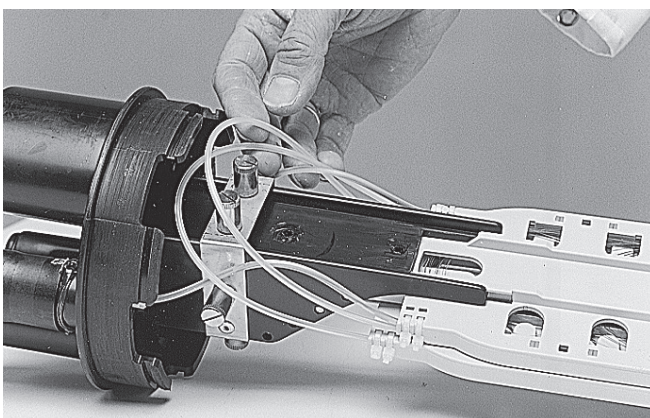

7.4.4 Route the fibers in the jumper tube.

7.4.5 Carefully bend the intertray jumper tube to the appropriate tray and secure to the splice tray with two tie-wraps.

7.4.6 The fibers may now be spliced or stored.

#### 7.5 Tray kit

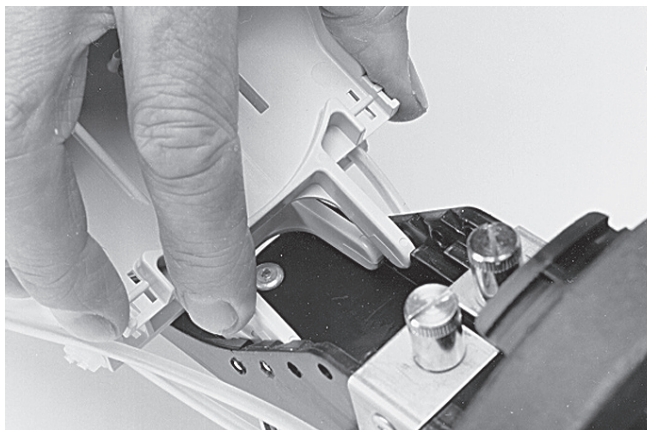

7.5.1 If additional trays are to be used, align the tray pins with the holes on base bracket. Squeeze tray pins and slip tray into bracket.

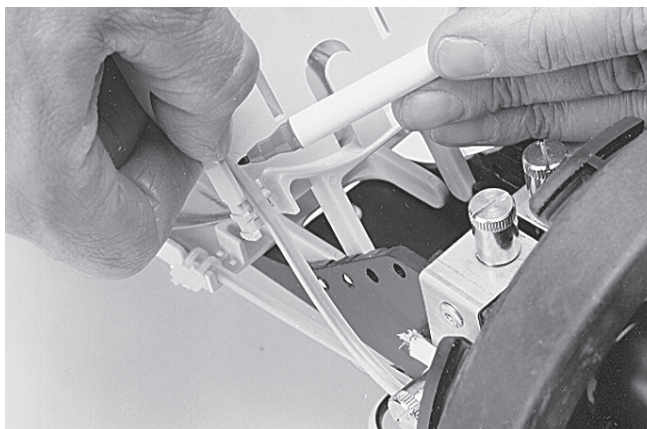

7.5.2 Proceed for fiber splicing as described from point 7. However, provide enough slack on transportation tube such that no severe bending or kinking of tube may occur during hinging.

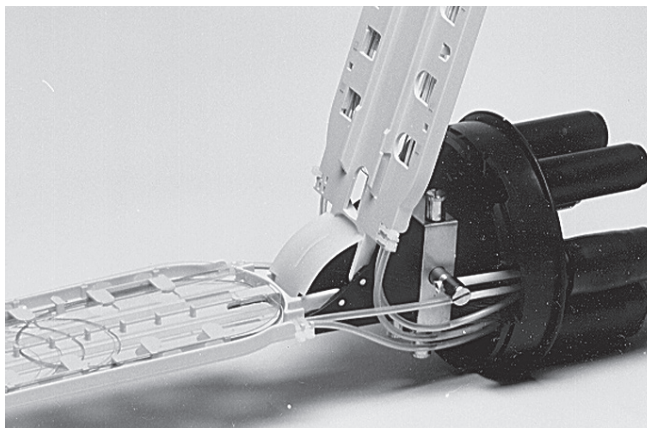

7.5.3 Use tray wedge to keep the tray in upward position.

## 8 Dome installation and closing the closure

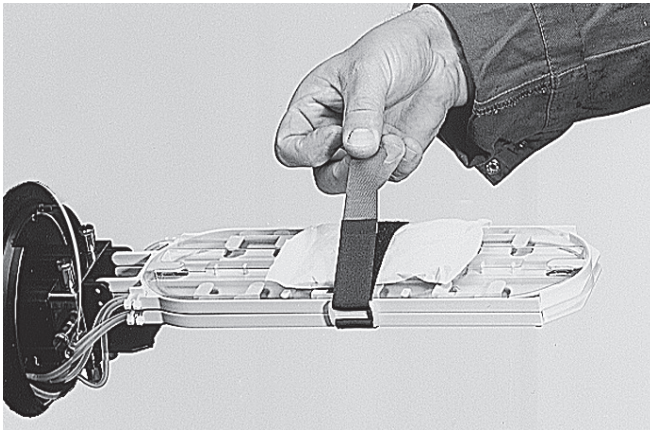

8.1 Open and remove the desiccant bag from its package and place the desiccant bag on the upper tray. Secure the trays and the desiccant bag with the hook and loop fastener strap.

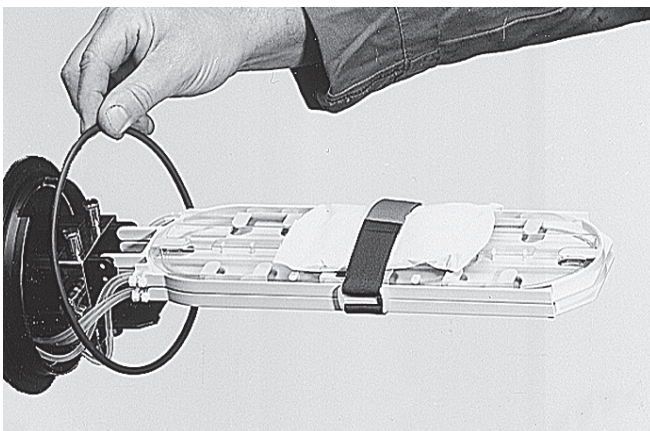

8.2 Ensure seal areas and sealing ring are clean and sealing ring is in place at the base.

**Important.** Make sure the sealing ring is well positioned.

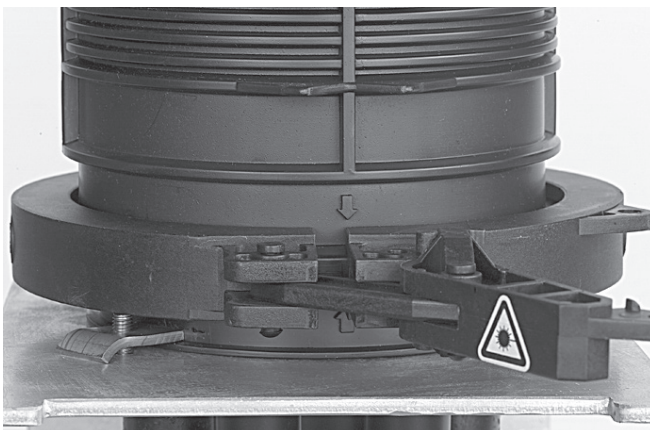

8.3 Place the dome over the closure base, the small flashes matching each other, and the closing handle of the locking ring should be in front on the position of the flashes.

## 9 Adjusting the pole bracket for installation on the pole or tower

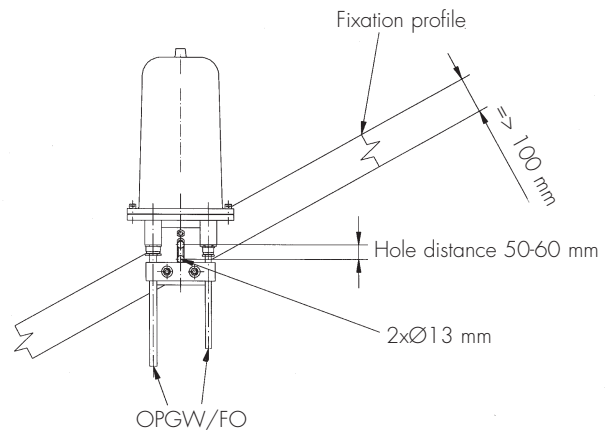

9.1 Determine the position of the closure for attachment to high voltage towers, poles, walls or other support structures.

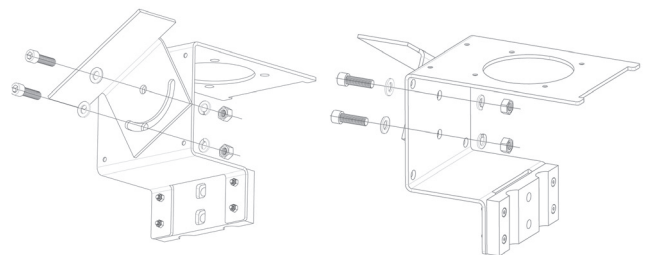
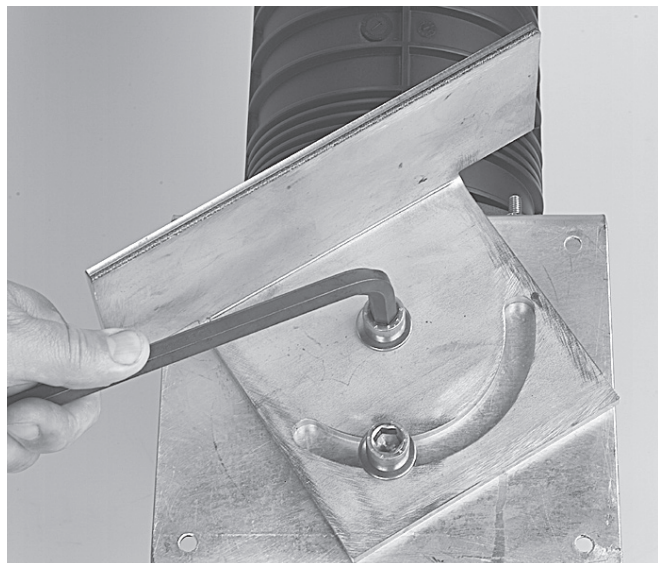

9.2 Tilt the closure till it is in vertical position and tighten the bolts of the support bracket (see picture and drawing).

## 10 Installation of the metal protection cover



10.1 Slide the metal cover over the closure and hook the front of the closure bracket in the slots on the front of the cover.

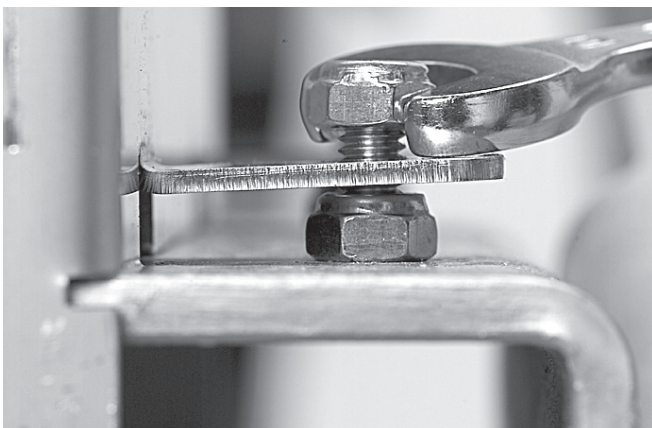

10.2 Position the backside of the cover over the two terminations bolts and tighten the nuts.

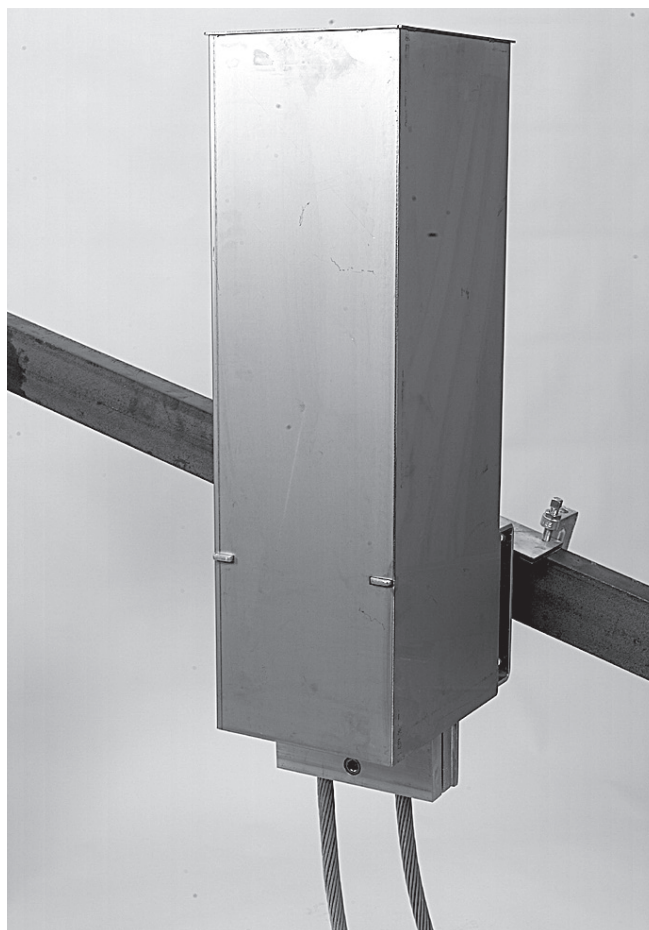

10.3 Install the closure on the proper position in the pole or power tower.