

AL7E78-PS



7/8 in EIA Flange Positive Stop™ for 1-5/8 in AVA7-50, AL7-50 and LDF7-50A coaxial cable

Product Classification

Product Type	Wireless and radiating connector
Product Brand	HELIAX®

General Specifications

Body Style	Straight
Cable Family	AL7-50 AVA7-50 LDF7-50A
Inner Contact Attachment Method	Captivated
Inner Contact Plating	Silver
Interface	7/8 in EIA Flange
Mounting Angle	Straight
Outer Contact Attachment Method	Ring-flare
Outer Contact Plating	Trimetal
Pressurizable	No

Dimensions

Length	134.11 mm 5.28 in
Diameter	62.74 mm 2.47 in
Nominal Size	1-5/8 in

Outline Drawing

AL7E78-PS

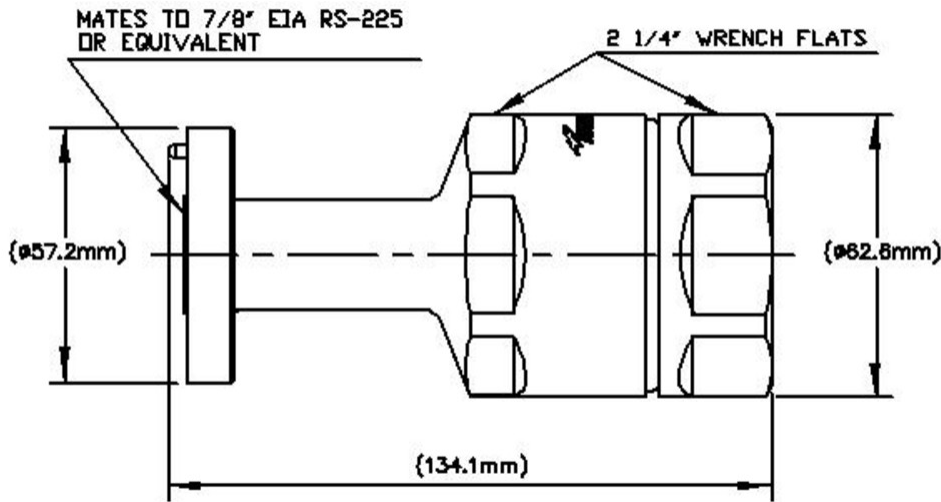

Electrical Specifications

3rd Order IMD at Frequency	-120 dBm @ 1800 MHz
3rd Order IMD Test Method	Two +43 dBm carriers
Insertion Loss Coefficient, typical	0.05
Average Power at Frequency	2.3 kW @ 900 MHz
Cable Impedance	50 ohm
Connector Impedance	50 ohm
dc Test Voltage	6000 V
Inner Contact Resistance, maximum	1.5 mOhm
Insulation Resistance, minimum	5000 MOhm
Operating Frequency Band	0 – 2500 MHz
Outer Contact Resistance, maximum	1.5 mOhm
Peak Power, maximum	90 kW
RF Operating Voltage, maximum (vrms)	2120 V
Shielding Effectiveness	-130 dB

VSWR/Return Loss

Frequency Band	VSWR	Return Loss (dB)
45–1000 MHz	1.036	35.05

AL7E78-PS

1010–2200 MHz	1.036	35.05
2210–2500 MHz	1.065	30.04

Mechanical Specifications

Attachment Durability	25 cycles
Connector Retention Tensile Force	2,224.11 N 500 lbf
Connector Retention Torque	13.56 N-m 119.998 in lb
Interface Durability	50 cycles
Mechanical Shock Test Method	MIL-STD-202, Method 213, Test Condition I

Environmental Specifications

Operating Temperature	-55 °C to +85 °C (-67 °F to +185 °F)
Storage Temperature	-55 °C to +85 °C (-67 °F to +185 °F)
Attenuation, Ambient Temperature	20 °C 68 °F
Average Power, Ambient Temperature	40 °C 104 °F
Corrosion Test Method	MIL-STD-1344A, Method 1001.1, Test Condition A
Immersion Depth	1 m
Immersion Test Mating	Mated
Immersion Test Method	IEC 60529:2001, IP68
Moisture Resistance Test Method	MIL-STD-202, Method 106
Thermal Shock Test Method	MIL-STD-202F, Method 107G, Test Condition A-1, Low Temperature -55 °C
Vibration Test Method	MIL-STD-202, Method 204, Test Condition B
Water Jetting Test Mating	Mated
Water Jetting Test Method	IEC 60529:2001, IP66

Packaging and Weights

Weight, net	1,097.4 g 2.419 lb
--------------------	----------------------

Regulatory Compliance/Certifications

Agency	Classification
ISO 9001:2015	Designed, manufactured and/or distributed under this quality management system



AL7E78-PS

* Footnotes

Insertion Loss Coefficient, typical $0.05\sqrt{\text{freq}}$ (GHz) (not applicable for elliptical waveguide)

Immersion Depth Immersion at specified depth for 24 hours