

CS-B-2



Cluster Support Bracket, u-bolt for 2-3/8 in OD round member attachment

Product Classification

Product Type Cluster Support Bracket

General Specifications

Cable Runs, quantity 7
Hole, quantity 7
Mounting Cluster support

Dimensions

Height 127 mm | 5 in
Width 228.6 mm | 9 in
Length 152.4 mm | 6 in
Pipe Outer Diameter 60.96 mm | 2.4 in
Hole Size 3/4 in | 7/16 in

CS-B-2

Outline Drawing

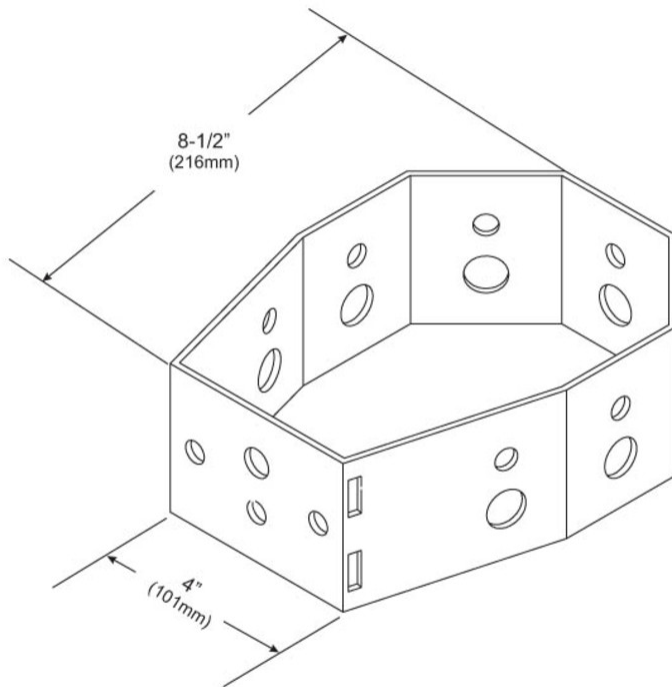

Material Specifications

Material Type Hot dip galvanized steel

Packaging and Weights

Included Brackets
Packaging quantity 1
Weight, net 1.8 kg | 3.968 lb

Regulatory Compliance/Certifications

Agency **Classification**

Included Products

- ACS-12 – Antenna and RRU Cable Support Bracket for up to 12 Cables
- CS-B – Cluster Support Bracket
- GUB-4240 – Galvanized U-bolt Assembly, 1/2 in x 2-1/2 in x 4 in
- PG-CS08 – PIM-Guard® Antenna and RRU Cable Support Bracket with 8 ports for stackable hangers (up to 3 per port). Install with torque wrench set at 10 to 15 ft-lb to meet carrier PIM requirements. For patents, see www.cs-pat.com
- PG-CS23 – PIM-Guard® Antenna and RRU Cable Support Bracket with 23 ports for stackable hangers (up to 3 per port). Install with torque wrench set at 10 to 15 ft-lb to meet carrier PIM requirements. For patents, see www.cs-pat.com
- PG-CSEB17 – PIM-Guard® Expansion Bracket - expands PG-CS08 Cable Support Bracket to 23 Ports. For patents, see www.cs-pat.com
- PG-RM06 – PIM-Guard® Round Member Cable Support Bracket 6 ports for stackable hangers (up to 3 per port). Install with torque wrench set at 5 to 7 ft-lb to meet carrier PIM requirements. For patents, see www.cs-pat.com
- PG-RMBH12 – PIM-Guard® Round Member Cable Support Bracket for Block Hangers - Two 3/8" stainless steel threaded rods for up to 12 hangers. Install with torque wrench set at 10 to 15 ft-lb to meet carrier PIM requirements.
- PG-RMBH12-BP – PIM-Guard® Round Member Cable Support Bracket for Block Hangers (pkg of 10) - Two 3/8" stainless steel threaded rods for up to 12 hangers. Install with torque wrench set at 10 to 15 ft-lb to meet carrier PIM requirements.

ACS-12

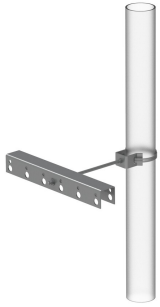

Antenna and RRU Cable Support Bracket for up to 12 Cables

Product Classification

Product Type Antenna/RRU Cable Support

General Specifications

Cable Runs, quantity 12

Hole, quantity 12

Dimensions

Width 419.1 mm | 16.5 in

Length 294.64 mm | 11.6 in

Mounting Diameter, maximum 50.8 mm | 2 in

Mounting Diameter, minimum 254 mm | 10 in

Hole Size 3/4 in | 7/16 in

Material Specifications

Material Type Hot dip galvanized steel

Packaging and Weights

Packaging quantity 1

Weight, net 2 kg | 4.409 lb

Regulatory Compliance/Certifications

Agency	Classification
CHINA-ROHS	Below maximum concentration value
ISO 9001:2015	Designed, manufactured and/or distributed under this quality management system
REACH-SVHC	Compliant as per SVHC revision on www.commscope.com/ProductCompliance

ACS-12

ROHS Compliant

UK-ROHS Compliant





Cluster Support Bracket

Product Classification

Product Type Cluster Support Bracket

General Specifications

Cable Runs, quantity 7

Hole, quantity 7

Mounting Cluster support

Dimensions

Height 127 mm | 5 in

Width 228.6 mm | 9 in

Length 152.4 mm | 6 in

Pipe Outer Diameter 60.96 mm | 2.4 in

Hole Size 3/4 in | 7/16 in

CS-B

Outline Drawing

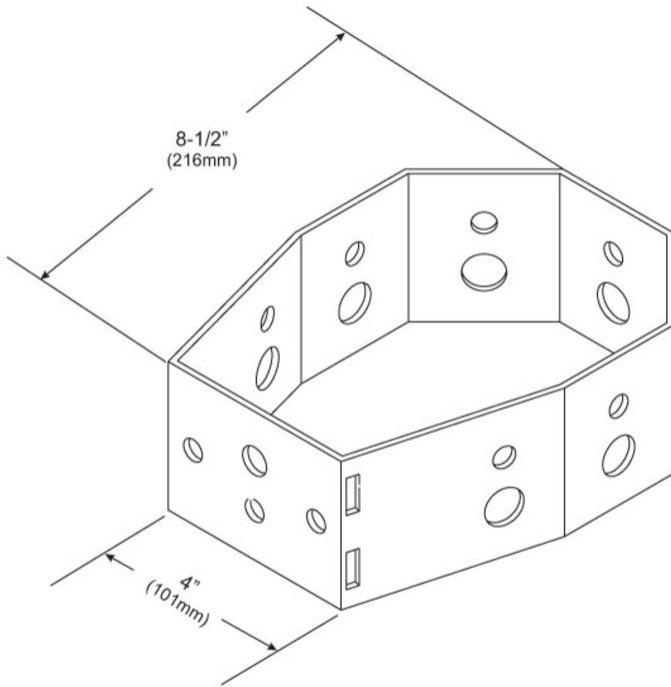

Material Specifications

Material Type Hot dip galvanized steel

Packaging and Weights

Included Brackets
Packaging quantity 1
Weight, net 1.4 kg | 3.086 lb

Regulatory Compliance/Certifications

Agency **Classification**

CS-B

ISO 9001:2015	Designed, manufactured and/or distributed under this quality management system
REACH-SVHC	Compliant as per SVHC revision on www.commscope.com/ProductCompliance
ROHS	Compliant
UK-ROHS	Compliant

GUB-4240

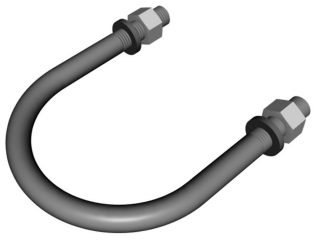

Galvanized U-bolt Assembly, 1/2 in x 2-1/2 in x 4 in

Product Classification

Product Type U-bolt

Dimensions

Height 101.6 mm | 4 in

Width 25.4 mm | 1 in

Length 101.6 mm | 4 in

Pipe Outer Diameter 12.7 mm | 0.5 in

Throat Dimension 63.5 mm | 2.5 in

Material Specifications

Material Type Hot dip galvanized steel

Packaging and Weights

Included Nuts | U-bolts | Washers

Packaging quantity 1

Weight, net 0.3 kg | 0.661 lb

Regulatory Compliance/Certifications

Agency	Classification
CHINA-ROHS	Below maximum concentration value
ISO 9001:2015	Designed, manufactured and/or distributed under this quality management system
REACH-SVHC	Compliant as per SVHC revision on www.commscope.com/ProductCompliance
ROHS	Compliant
UK-ROHS	Compliant



PG-CS08



PIM-Guard® Antenna and RRU Cable Support Bracket with 8 ports for stackable hangers (up to 3 per port). Install with torque wrench set at 10 to 15 ft-lb to meet carrier PIM requirements. For patents, see www.cs-pat.com

Product Classification

Product Type	Antenna/RRU Cable Support
Product Brand	PIM-Guard®

General Specifications

Cable Runs, quantity	8
Hole, quantity	8
Mounting	Pipe, 60.3–114.3 mm (2-3/8 in to 4-1/2 in) OD

Dimensions

Height	55.88 mm 2.2 in
Width	248.92 mm 9.8 in
Length	317.5 mm 12.5 in
Mounting Diameter, maximum	60.96 mm 2.4 in
Mounting Diameter, minimum	114.3 mm 4.5 in
Hole Size	3/4 in 7/16 in

Material Specifications

Material Type	Hot dip galvanized steel
----------------------	--------------------------

Packaging and Weights

Packaging quantity	1
Weight, net	4.1 kg 9.039 lb

Regulatory Compliance/Certifications

Agency	Classification
CHINA-ROHS	Below maximum concentration value
ISO 9001:2015	Designed, manufactured and/or distributed under this quality management system

PG-CS08

REACH-SVHC

Compliant as per SVHC revision on www.commscope.com/ProductCompliance

ROHS

Compliant

UK-ROHS

Compliant



PG-CS23

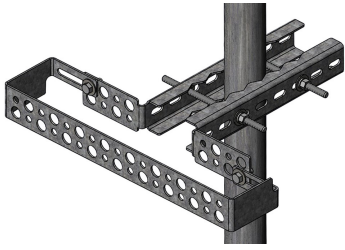

PIM-Guard® Antenna and RRU Cable Support Bracket with 23 ports for stackable hangers (up to 3 per port). Install with torque wrench set at 10 to 15 ft-lb to meet carrier PIM requirements. For patents, see www.cs-pat.com

Product Classification

Product Type	Antenna/RRU Cable Support
Product Brand	PIM-Guard®

General Specifications

Cable Runs, quantity	23
Hole, quantity	23
Mounting	Pipe, 60.3–114.3 mm (2-3/8 in to 4-1/2 in) OD

Dimensions

Height	55.88 mm 2.2 in
Width	457.2 mm 18 in
Length	419.1 mm 16.5 in
Mounting Diameter, maximum	60.96 mm 2.4 in
Mounting Diameter, minimum	114.3 mm 4.5 in
Hole Size	3/4 in 7/16 in

Material Specifications

Material Type	Hot dip galvanized steel
----------------------	--------------------------

Packaging and Weights

Packaging quantity	1
Weight, net	5.1 kg 11.244 lb

Regulatory Compliance/Certifications

Agency	Classification
CHINA-ROHS	Below maximum concentration value
ISO 9001:2015	Designed, manufactured and/or distributed under this quality management system

PG-CS23

REACH-SVHC

Compliant as per SVHC revision on www.commscope.com/ProductCompliance

ROHS

Compliant

UK-ROHS

Compliant



PG-CSEB17

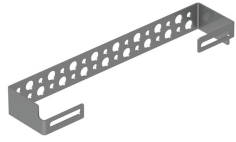

PIM-Guard® Expansion Bracket - expands PG-CS08 Cable Support Bracket to 23 Ports. For patents, see www.cs-pat.com

Product Classification

Product Type	Antenna/RRU Cable Support
Product Brand	PIM-Guard®

General Specifications

Cable Runs, quantity	17
Hole, quantity	17

Dimensions

Height	55.88 mm 2.2 in
Width	457.2 mm 18 in
Length	101.6 mm 4 in
Hole Size	3/4 in 7/16 in

Material Specifications

Material Type	Hot dip galvanized steel
----------------------	--------------------------

Packaging and Weights

Packaging quantity	1
Weight, net	0.8 kg 1.764 lb

Regulatory Compliance/Certifications

Agency	Classification
CHINA-ROHS	Below maximum concentration value
ISO 9001:2015	Designed, manufactured and/or distributed under this quality management system
REACH-SVHC	Compliant as per SVHC revision on www.commscope.com/ProductCompliance

PG-CSEB17

ROHS Compliant

UK-ROHS Compliant



PG-RM06

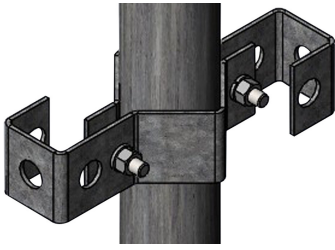

PIM-Guard® Round Member Cable Support Bracket 6 ports for stackable hangers (up to 3 per port). Install with torque wrench set at 5 to 7 ft-lb to meet carrier PIM requirements. For patents, see www.cs-pat.com

Product Classification

Product Type	Antenna/RRU Cable Support
Product Brand	PIM-Guard®

General Specifications

Cable Runs, quantity	6
Hole, quantity	6
Mounting	Pipe, 60.3–88.9 mm (2-3/8 in to 3-1/2 in) OD

Dimensions

Height	50.8 mm 2 in
Width	50.8 mm 2 in
Length	198.12 mm 7.8 in
Mounting Diameter, maximum	60.96 mm 2.4 in
Mounting Diameter, minimum	88.9 mm 3.5 in
Hole Size	3/4 in

Material Specifications

Material Type	Hot dip galvanized steel
----------------------	--------------------------

Packaging and Weights

Packaging quantity	1
Weight, net	2.3 kg 5.071 lb

Regulatory Compliance/Certifications

Agency	Classification
CHINA-ROHS	Below maximum concentration value
ISO 9001:2015	Designed, manufactured and/or distributed under this quality management system

PG-RM06

REACH-SVHC

Compliant as per SVHC revision on www.commscope.com/ProductCompliance

ROHS

Compliant

UK-ROHS

Compliant



PG-RMBH12



PIM-Guard® Round Member Cable Support Bracket for Block Hangers - Two 3/8" stainless steel threaded rods for up to 12 hangers. Install with torque wrench set at 10 to 15 ft-lb to meet carrier PIM requirements.

Product Classification

Product Type	Antenna/RRU Cable Support
Product Brand	PIM-Guard®

General Specifications

Cable Runs, quantity	12
Mounting	Pipe, 60.3–88.9 mm (2-3/8 in to 3-1/2 in) OD

Dimensions

Height	1.5 in 38.1 mm
Width	5.5 in 139.7 mm
Length	12 in 304.8 mm
Mounting Diameter, maximum	2.4 in 60.96 mm
Mounting Diameter, minimum	3.5 in 88.9 mm

Material Specifications

Material Type	Hot dip galvanized steel Stainless steel
----------------------	--

Packaging and Weights

Included	Attachment hardware Clamps Threaded rod
Packaging quantity	1
Weight, net	2.6 kg 5.732 lb

Regulatory Compliance/Certifications

Agency	Classification
ISO 9001:2015	Designed, manufactured and/or distributed under this quality management system

PG-RMBH12-BP



PIM-Guard® Round Member Cable Support Bracket for Block Hangers (pkg of 10)- Two 3/8" stainless steel threaded rods for up to 12 hangers. Install with torque wrench set at 10 to 15 ft-lb to meet carrier PIM requirements.

Product Classification

Product Type	Antenna/RRU Cable Support
Product Brand	PIM-Guard®

General Specifications

Cable Runs, quantity	12
Mounting	Pipe, 60.3–88.9 mm (2-3/8 in to 3-1/2 in) OD

Dimensions

Height	38.1 mm 1.5 in
Width	139.7 mm 5.5 in
Length	304.8 mm 12 in
Mounting Diameter, maximum	60.96 mm 2.4 in
Mounting Diameter, minimum	88.9 mm 3.5 in

Material Specifications

Material Type	Hot dip galvanized steel Stainless steel
----------------------	--

Packaging and Weights

Included	Attachment hardware Clamps Threaded rod
Packaging quantity	10
Weight, net	2.6 kg 5.732 lb

Regulatory Compliance/Certifications

Agency	Classification
ISO 9001:2015	Designed, manufactured and/or distributed under this quality management system