

- 1.0 GENERAL NOTES
 1.1 ALL IMPERIAL DIMENSIONS ARE IN BRACKETS [X.XX]
 1.2 MARK PART WITH IDENTIFICATION NUMBER
 2.0 DESIGN NOTES
 3.0 MANUFACTURING/SPECIAL REQUIREMENTS
 3.1 TIGHTEN ALL BOLTS SECURING FLAT PLATES BY THE TURN-OF-NUT METHOD. TIGHTEN ALL U-BOLTS USING TURN-OF-NUT METHOD WITH ATTENTION TO LEAVE EQUAL DISTANCE AND EQUAL FORCE ON EACH LEG OF THE U-BOLT.
 4.0 TEST
 5.0 PACKAGING
 5.1 PACKAGING SHALL MEET COMMScope REQUIREMENTS PER DOCUMENT IS-PL-3005
 5.2 PRINTED DOCUMENT TO BE PLACED INSIDE POLYBAG AND THEN IN SHIPPING CONTAINER
 5.3 EXTRA HARDWARE MAYBE SUPPLIED, BAGGED AND SHIPPED

REVISIONS			
REV.	DESCRIPTION	DATE	APPROVED
A	INITIAL RELEASE	JL1183 16MAR23	JAHAINES 40168212CMO

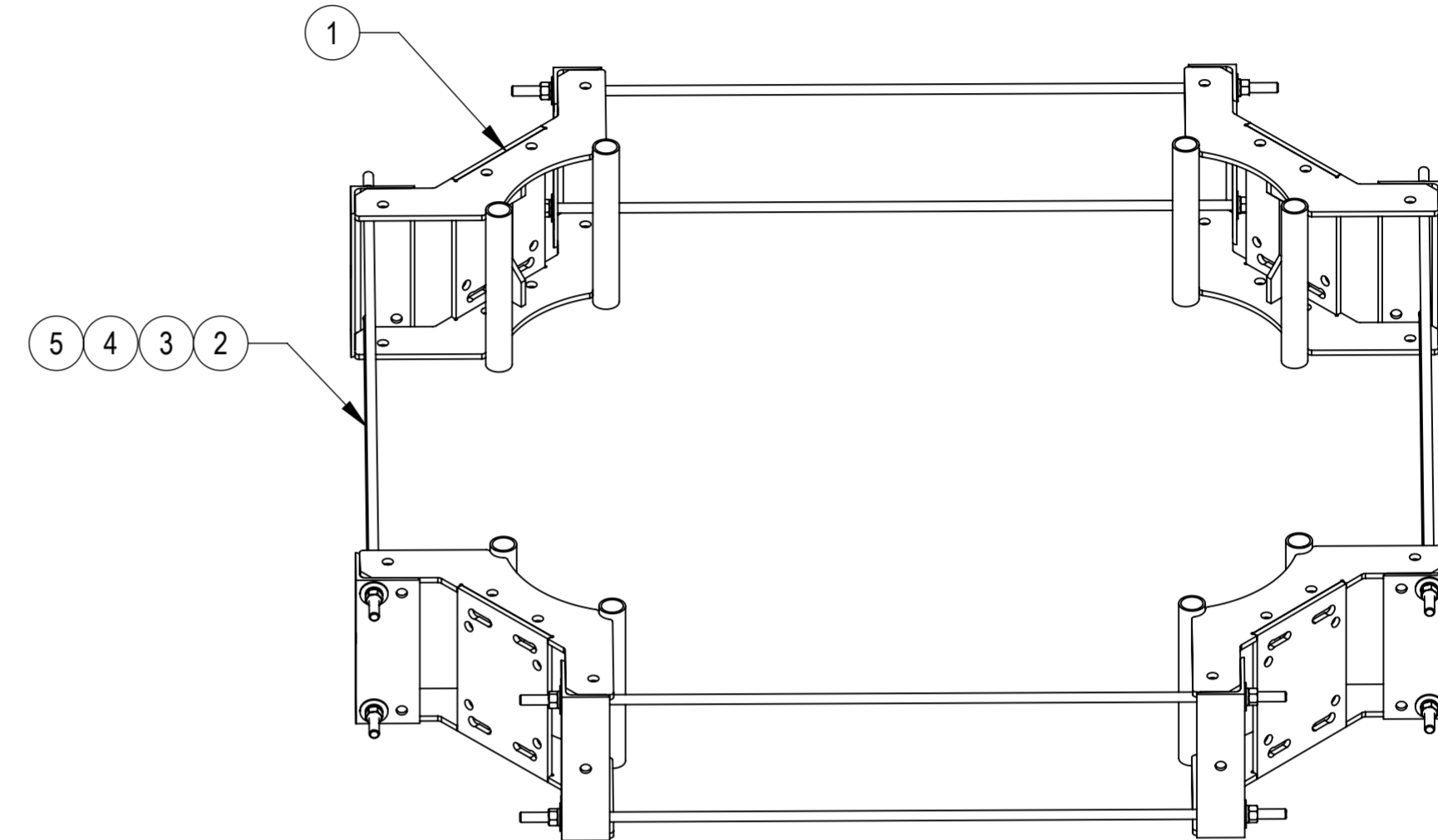
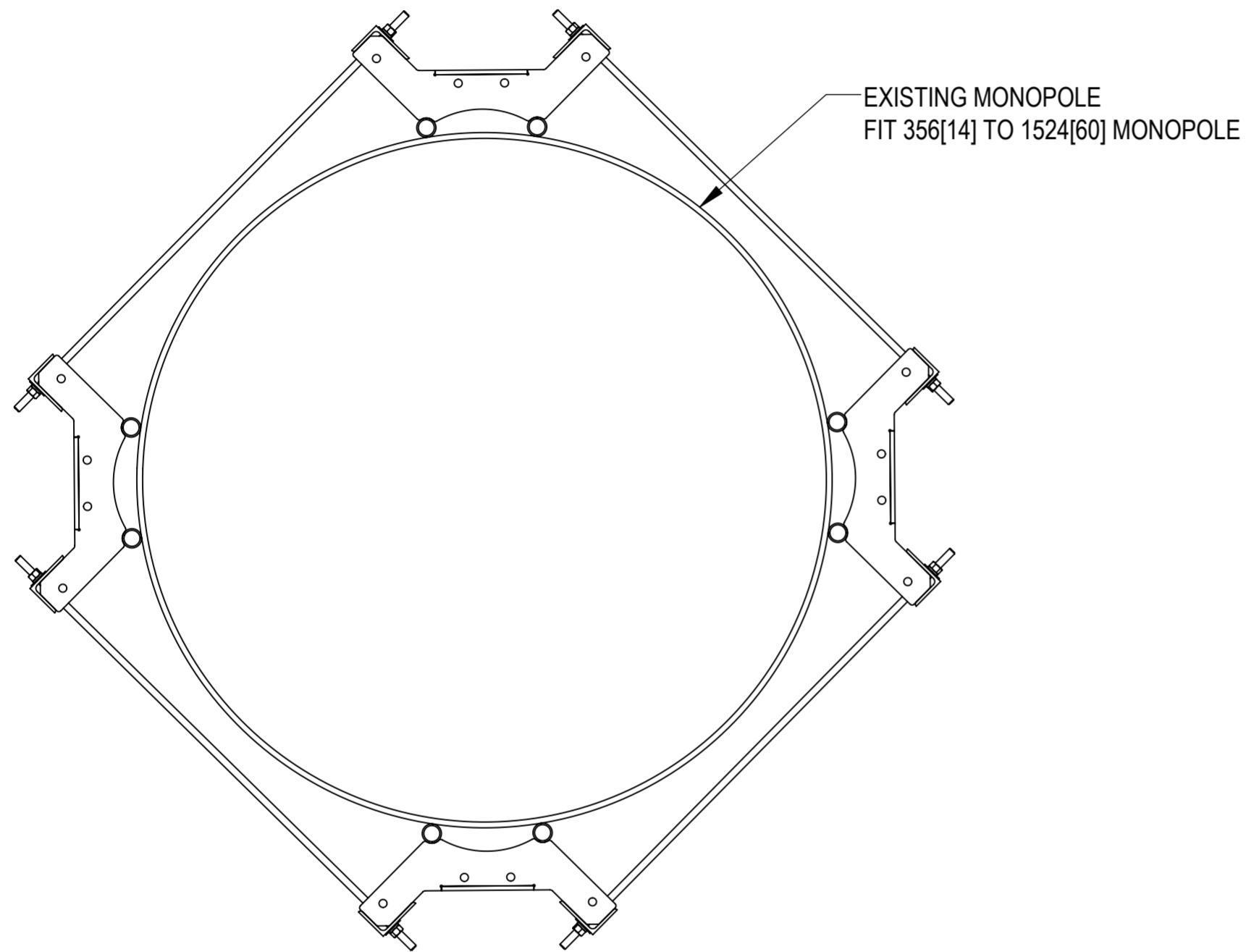

COMPONENT PART NUMBERS PROVIDED FOR ASSEMBLY PURPOSES;
 INDIVIDUAL COMPONENTS MAY BE SHIPPED AS PARTS WITHIN AN INCLUDED KIT.

ITEM NO.	PART NO.	DESCRIPTION	QTY.	NOTE NO.
1	CM-1460	WELDMENT, COLLAR MOUNT	4	
2	MT38248	5/8" X 48" GALV THREADED ROD	8	
3	GWF-05	5/8" GALV FLAT WASHER, 1.7OD	16	
4	GWL-05	5/8" GALV LOCK WASHER	4	
5	GN-05	5/8" GALV HEX NUT	16	
6	LOCK WASHER SPRING REGULAR_AI	LOCK WASHER, 1/4" SS (EA)	12	

COMMScope, INC. OF NORTH CAROLINA

TOLERANCES		SAP MATERIAL MASTER	
0 PLACE X[.X] ± 6[0.25]	2 PLACE .XX[.XXX] ± 1.50[0.06]	MUK-PLK7Q	
1 PLACE .X[.XX] ± 3.0[0.12]	ANGLES ± 2°		
FINISH		MATERIAL	
<small>UNLESS OTHERWISE SPECIFIED DIMENSIONS ARE IN MILLIMETERS INTERPRET PER ANSI Y 14.5M-1994</small>		NAME	DATE
		CE JL1183	16MAR23
		RW YMENG	03/24/2023
		AD YW1045	03/24/2023
TITLE		SCALE	
4-SIDED COLLAR MOUNT ASSEMBLY		1:10	
		DOCUMENT NO. MUK-PLK7Q	
ECN 40168212CMO	SIZE	Auth Group	INSL
HEIGHT (1737[68.4])	A2	MODEL	DRAWING
LENGTH (1737[68.4])		VERSION	STATUS
WIDTH 302[11.9]		01	RE
		REVISION	VERSION
		B	00
		REVISION	STATUS
		A	RE
		REVISION	STATUS
		A	RE
		REVISION	STATUS
		A	RE
		REVISION	STATUS
		A	RE
		REVISION	STATUS
		A	RE
		REVISION	STATUS
		A	RE