

- 1.0 GENERAL NOTES
 - 1.1 ALL METRIC DIMENSIONS ARE IN BRACKETS [X.X]
 - 1.2 FOR PATENT INFO: <https://www.cs-pat.com>
- 2.0 DESIGN NOTES
- 3.0 MANUFACTURING/SPECIAL REQUIREMENTS
 - 3.1 TIGHTEN ALL BOLTS SECURING FLAT PLATES BY THE TURN-OF-NUT METHOD. TIGHTEN ALL U-BOLTS USING TURN-OF-NUT METHOD WITH ATTENTION TO LEAVE EQUAL DISTANCE AND EQUAL FORCE ON EACH LEG OF THE U-BOLT.
- 4.0 TEST
- 5.0 PACKAGING
 - 5.1 PACKAGING SHALL MEET COMMSCOPE REQUIREMENTS PER DOCUMENT IS-PL-3005
 - 5.2 PRINTED DOCUMENT TO BE PLACED INSIDE POLYBAG AND THEN IN SHIPPING CONTAINER
 - 5.3 EXTRA HARDWARE MAY BE SUPPLIED, BAGGED AND SHIPPED

REVISIONS			
REV.	DESCRIPTION	DATE	APPROVED
A	INITIAL RELEASE	JL1183 01SEP22	VICENTE 40155958CMO
B	ADDED PACKAGE VIEW	LS1146 23MAY24	CR1091 40196241CMO

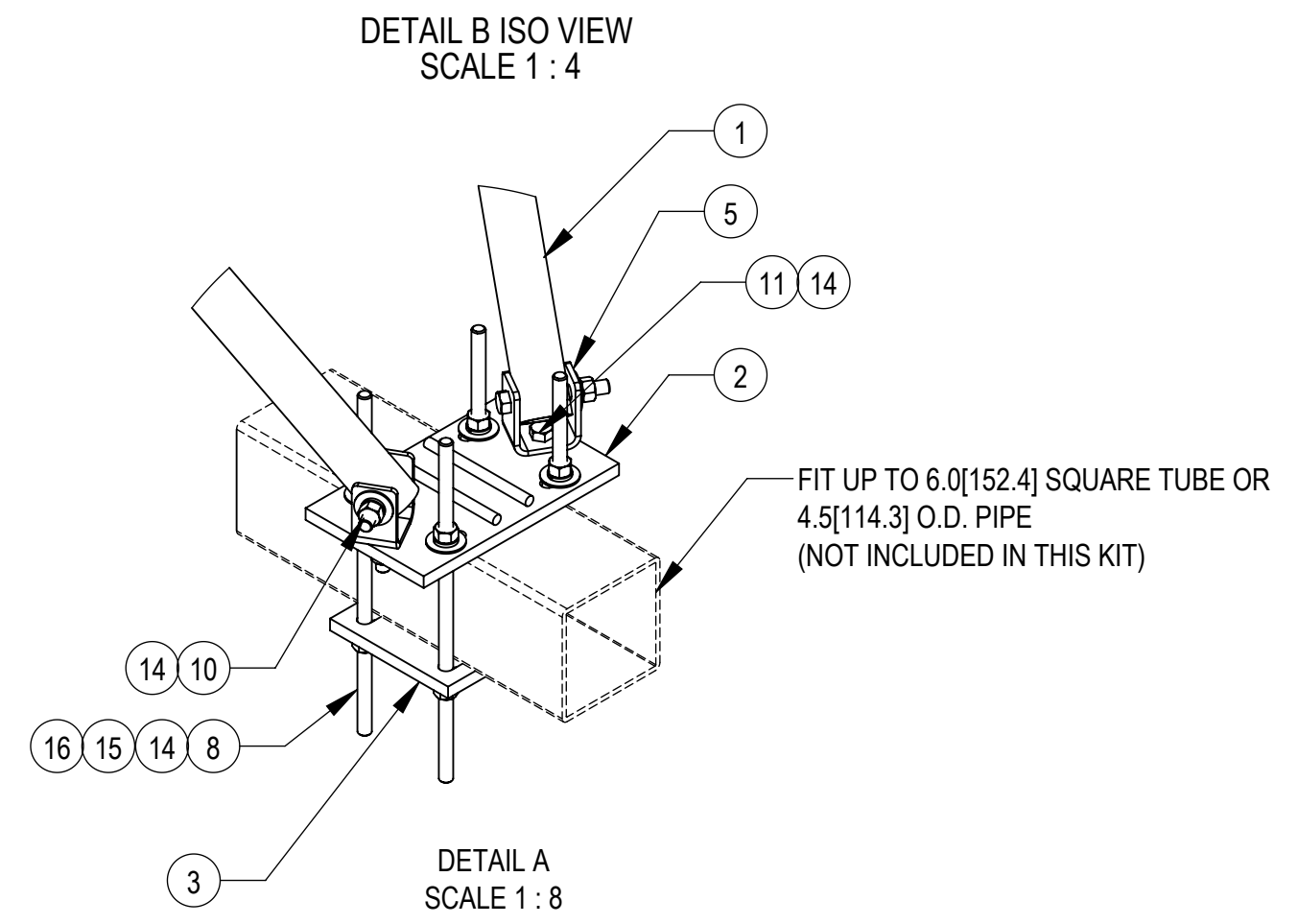
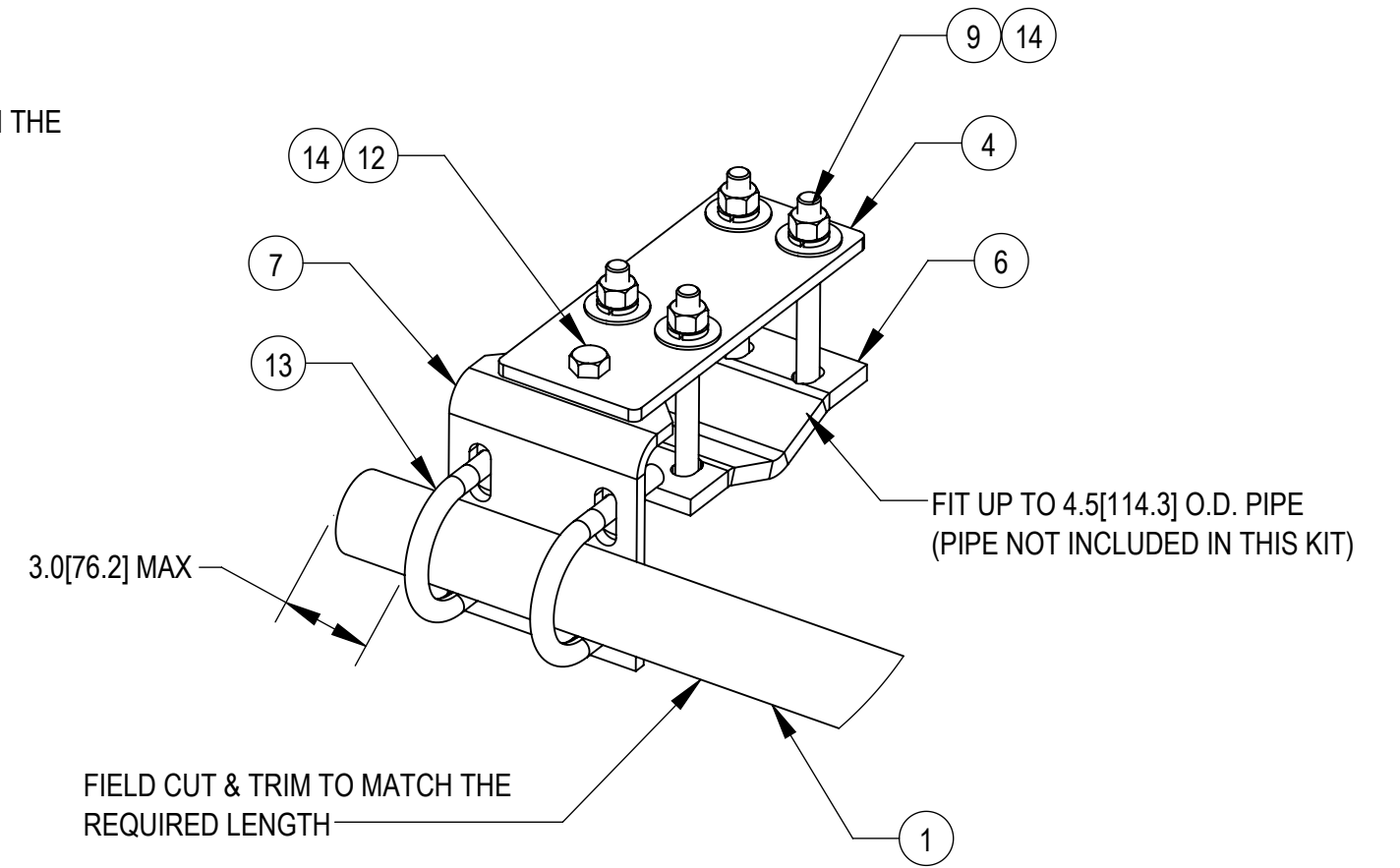
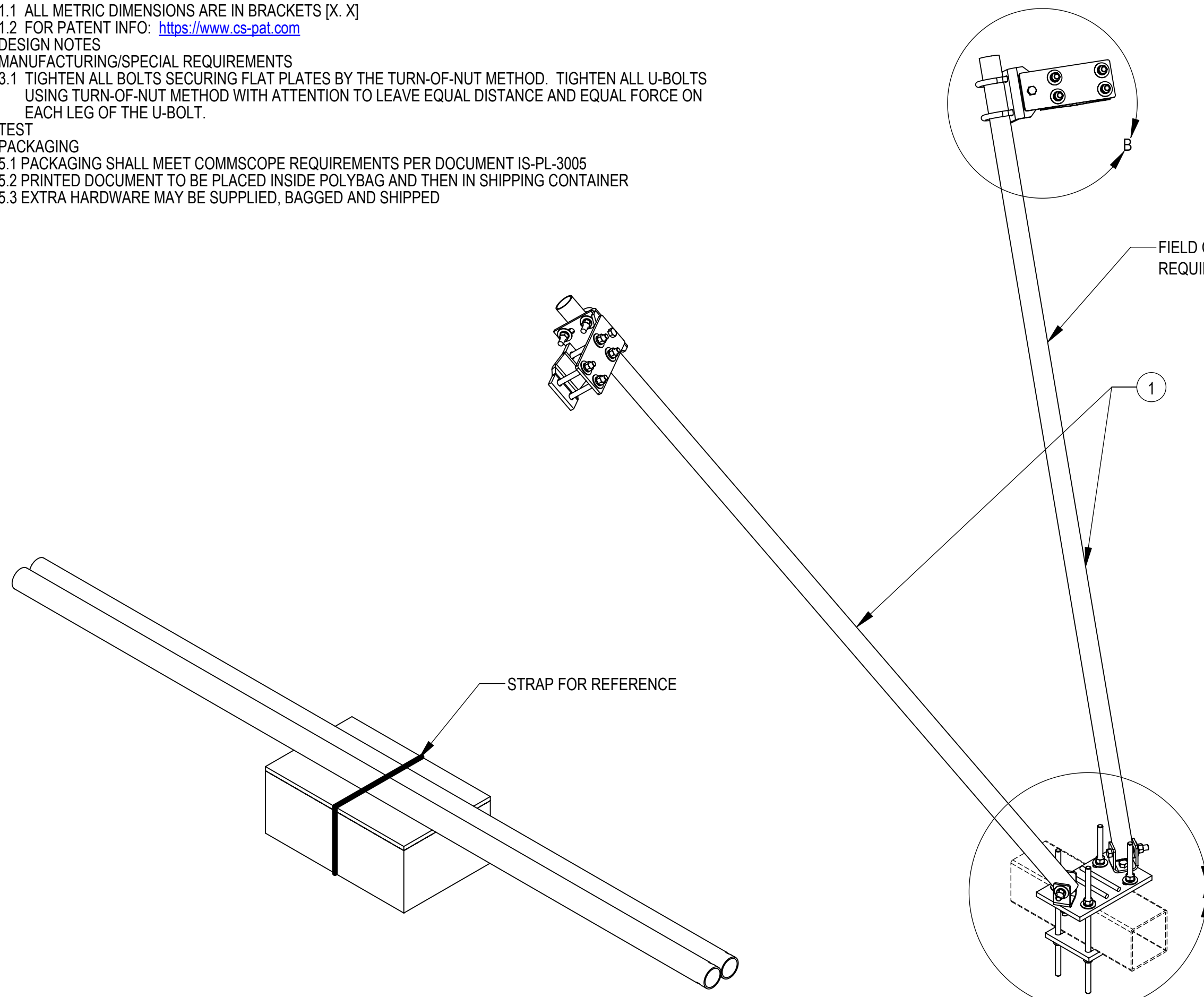

PACKING VIEW

COMPONENT PART NUMBERS PROVIDED FOR ASSEMBLY PURPOSES;
INDIVIDUAL COMPONENTS MAY BE SHIPPED AS PARTS WITHIN AN INCLUDED KIT.

ITEM	PART NO.	DESCRIPTION	QTY.	WEIGHT	NOTE NO.
1	P40-238X096	PIPE 2 SCH40 (2.375" OD x0.154" THK)	2	29.30 LBS	
2	PL625-72512	WELDMENT, TOP MOUNTING PLATE	1	15.39 LBS	
3	PLK8-F2-3	WELDMENT, BOTTOM MOUNTING PLATE	1	11.63 LBS	
4	PL375-4511	PLATE, TIE BACK MOUNTING	2	5.07 LBS	
5	MTC4104-0031	BENT PLATE	2	1.14 LBS	
6	V-CLAMP	CLAMP, 4 SLOT V	2	4.90 LBS	
7	MTC4104-0014	BENT PLATE, .375 X 6 X 6.88	2	5.24 LBS	
8	MT-382-18	5/8" X 18" GALV THREADED ROD	4	1.55 LBS	
9	GB-05605FT	5/8" X 6" GALV BOLT KIT FULL THREAD	8	0.59 LBS	INCLUDED BOLT, LOCK WASHER AND NUT
10	GB-0544A	5/8" X 4-1/2" GALV BOLT KIT	2	0.48 LBS	INCLUDED BOLT, LOCK WASHER AND NUT
11	GB-0522A	5/8" X 2-1/4" GALV BOLT KIT (A325)	2	0.28 LBS	INCLUDED BOLT, LOCK WASHER AND NUT
12	GB-0520A	5/8" X 2" GALV BOLT KIT (A325)	2	0.26 LBS	INCLUDED BOLT, LOCK WASHER AND NUT
13	GUB-53050	5/8" X 3" X 5" GALV U-BOLT KIT	4	1.09 LBS	INCLUDES U-BOLT, FLAT WASHERS, LOCK WASHERS AND NUTS
14	GWF-05	5/8" GALV FLAT WASHER, 1.7OD	22	0.06 LBS	
15	GWL-05	5/8" GALV LOCK WASHER	8	0.03 LBS	
16	GN-05	5/8" GALV HEX NUT	8	0.08 LBS	

DENSITY		lbs/in ³
MASS	138.37	lbs
VOLUME	495.44	in ³
SURFACE AREA	4513.04	in ²
HEIGHT	89.2"	
LENGTH	92.4"	
WIDTH	57.7"	

COMMSCOPE, INC. OF NORTH CAROLINA

TOLERANCES		SAP MATERIAL MASTER													
1 PLACE .X[X] ± 0.2[6.3]	3 PLACE .XXX[X] ± 0.060[1.5]	VZWSMART-PLK10													
2 PLACE .XX[X] ± 0.12[3.0]	ANGLES ± 2°														
FINISH		MATERIAL													
SUPPORT RAIL BRACING KIT															
UNLESS OTHERWISE SPECIFIED DIMENSIONS ARE IN INCHES INTERPRET PER ANSI Y 14.5M-1994		SCALE DOCUMENT NO.													
<table border="1" style="font-size: small;"> <thead> <tr> <th>NAME</th> <th>DATE</th> <th>TITLE</th> </tr> </thead> <tbody> <tr> <td>CE JL1183</td> <td>01SEP22</td> <td rowspan="4" style="text-align: center; vertical-align: middle;">VZWSMART-PLK10</td> </tr> <tr> <td>RW YMENG</td> <td>06/10/2024</td> </tr> <tr> <td>AD JL1183</td> <td>06/10/2024</td> </tr> <tr> <td>RE YMENG</td> <td>06/10/2024</td> </tr> </tbody> </table>		NAME	DATE	TITLE	CE JL1183	01SEP22	VZWSMART-PLK10	RW YMENG	06/10/2024	AD JL1183	06/10/2024	RE YMENG	06/10/2024	1:10	
NAME	DATE	TITLE													
CE JL1183	01SEP22	VZWSMART-PLK10													
RW YMENG	06/10/2024														
AD JL1183	06/10/2024														
RE YMENG	06/10/2024														
ECN 40196241CMO		DRAWING													
SIZE	Auth Group INSL	MODEL	VERSION STATUS REVISION												
C			00 RE A 01 RE B												
			SHEET 1 OF 1												