

4

3

2

1

- 1.0 GENERAL NOTES
 - 1.1 ALL METRIC DIMENSIONS ARE IN BRACKETS [X.X]
 - 1.2 FOR PATENT INFO: <https://www.cs-pat.com>

- 2.0 DESIGN NOTES
 - 2.1 ANY HAZARDS OR OBSTRUCTIONS TO THE CLIMBING FACILITY AND SAFETY CLIMB MUST BE IDENTIFIED PRIOR TO INSTALLING THE APPURTENANCE. ADDITIONAL PRODUCTS MAY BE REQUIRED TO MAINTAIN THE INTEGRITY OF THE SAFETY CLIMB. DURING INSTALLATION, TEMPORARY AND/OR PERMANENT PRECAUTIONARY MEASURES SHOULD BE TAKEN TO PRESERVE THE CLIMBING FACILITY AND/OR SAFETY CLIMB.
 - 2.2 UP TO 5.0° TAPER AVAILABLE ON MODELS THAT SUPPORT ADJUSTMENT

- 3.0 MANUFACTURING/SPECIAL REQUIREMENTS
 - 3.1 TIGHTEN ALL BOLTS SECURING FLAT PLATES BY THE TURN-OF-NUT METHOD. TIGHTEN ALL U-BOLTS USING TURN-OF-NUT METHOD WITH ATTENTION TO LEAVE EQUAL DISTANCE AND EQUAL FORCE ON EACH LEG OF THE U-BOLT.

- 4.0 TEST
- 5.0 PACKAGING
 - 5.1 PACKAGING SHALL MEET COMMSCOPE REQUIREMENTS PER DOCUMENT IS-PL-3005.
 - 5.2 PRINTED DOCUMENT TO BE PLACED INSIDE POLYBAG AND THEN IN SHIPPING CONTAINER.
 - 5.3 EXTRA HARDWARE MAYBE SUPPLIED, BAGGED AND SHIPPED.

REVISIONS			
REV.	DESCRIPTION	DATE	APPROVED
A	INITIAL RELEASE	YMENG 08OCT23	YW1047 40179448CMO

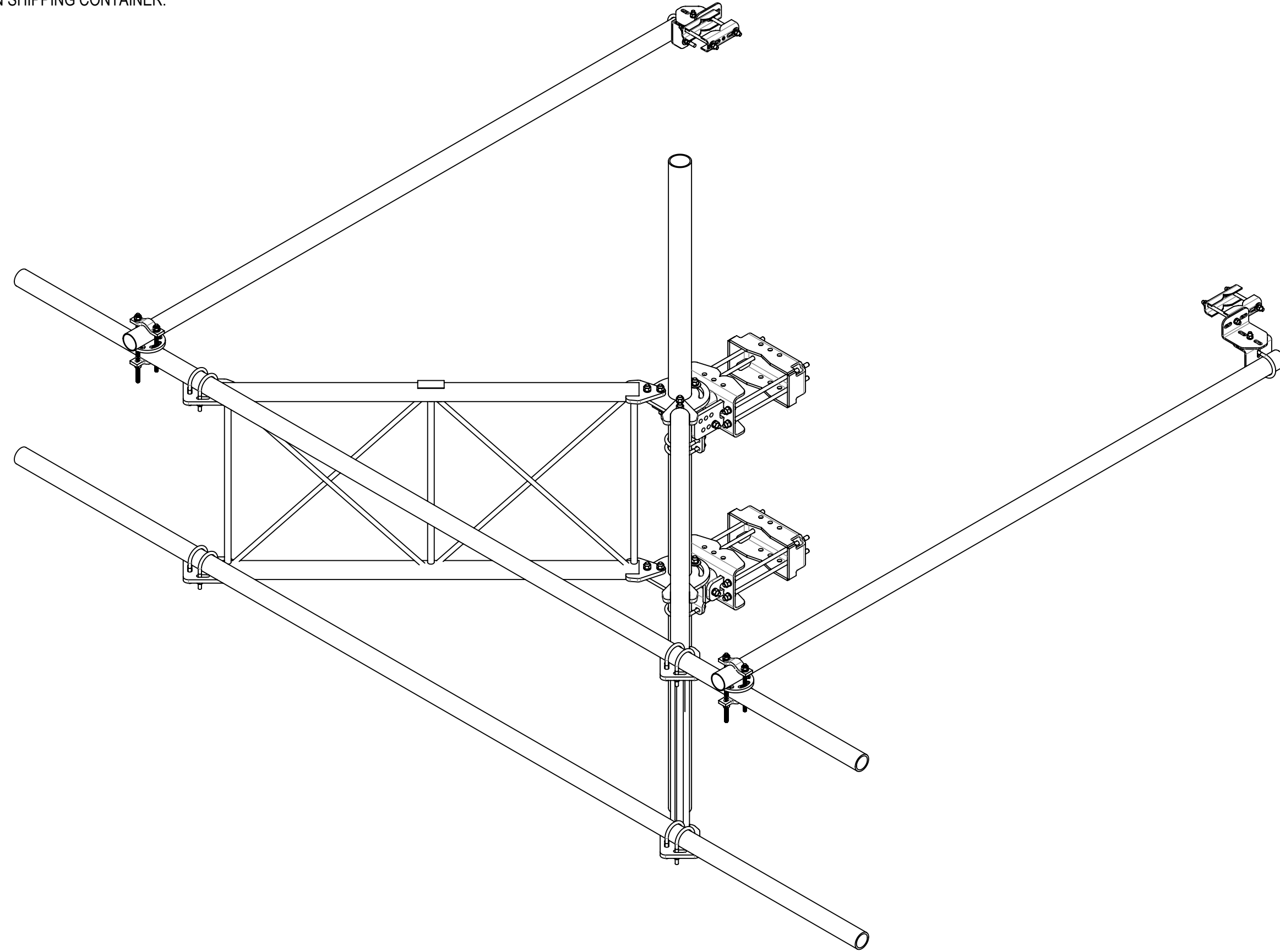

COMMSCOPE, INC. OF NORTH CAROLINA										
TOLERANCES					SAP MATERIAL MASTER					
1 PLACE .X[X] ± 0.2[6.3]		3 PLACE .XXX[X] ± 0.060[1.5]			SFG23RHDXL-15-B					
2 PLACE .XX[X] ± 0.12[3.0]		ANGLES ± 2°								
FINISH					MATERIAL					
SF, 15', BASE-KIT										
DENSITY		799.69		lbs/in ³						
MASS		799.69		lbs						
VOLUME		2821.67		in ³						
SURFACE AREA		23201.60		in ²						
HEIGHT		120"								
LENGTH		180"								
WIDTH		120"								
UNLESS OTHERWISE SPECIFIED DIMENSIONS ARE IN INCHES INTERPRET PER ANSI Y 14.5M-1994										
NAME		DATE		TITLE						
CE YMENG		08OCT23		SFG23RHDXL-15-B						
RW YMENG		10/18/2023								
AD YW1047		10/18/2023								
RE YMENG		10/18/2023								
ECN 40179448CMO										
SCALE		DOCUMENT NO.								
1:32		SFG23RHDXL-15-B								
SIZE		Auth Group		INSL		MODEL		DRAWING		SHEET
C		[Symbol]		[Symbol]		VERSION		STATUS		1 OF 5
		00		RE		A		00		RE A

4

3

2

1

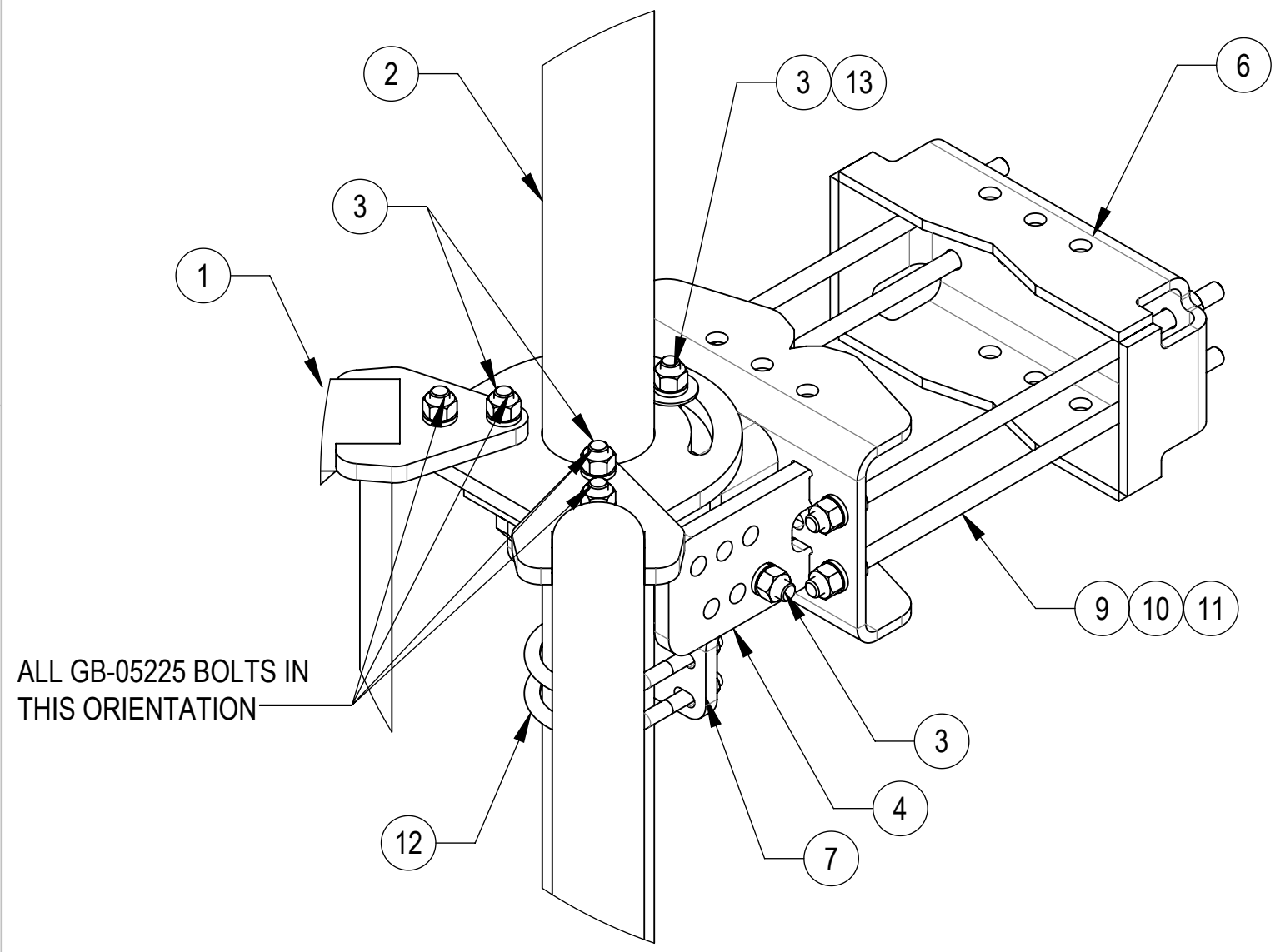

ALL GB-05225 BOLTS IN THIS ORIENTATION

DETAIL A
SCALE 1 : 5

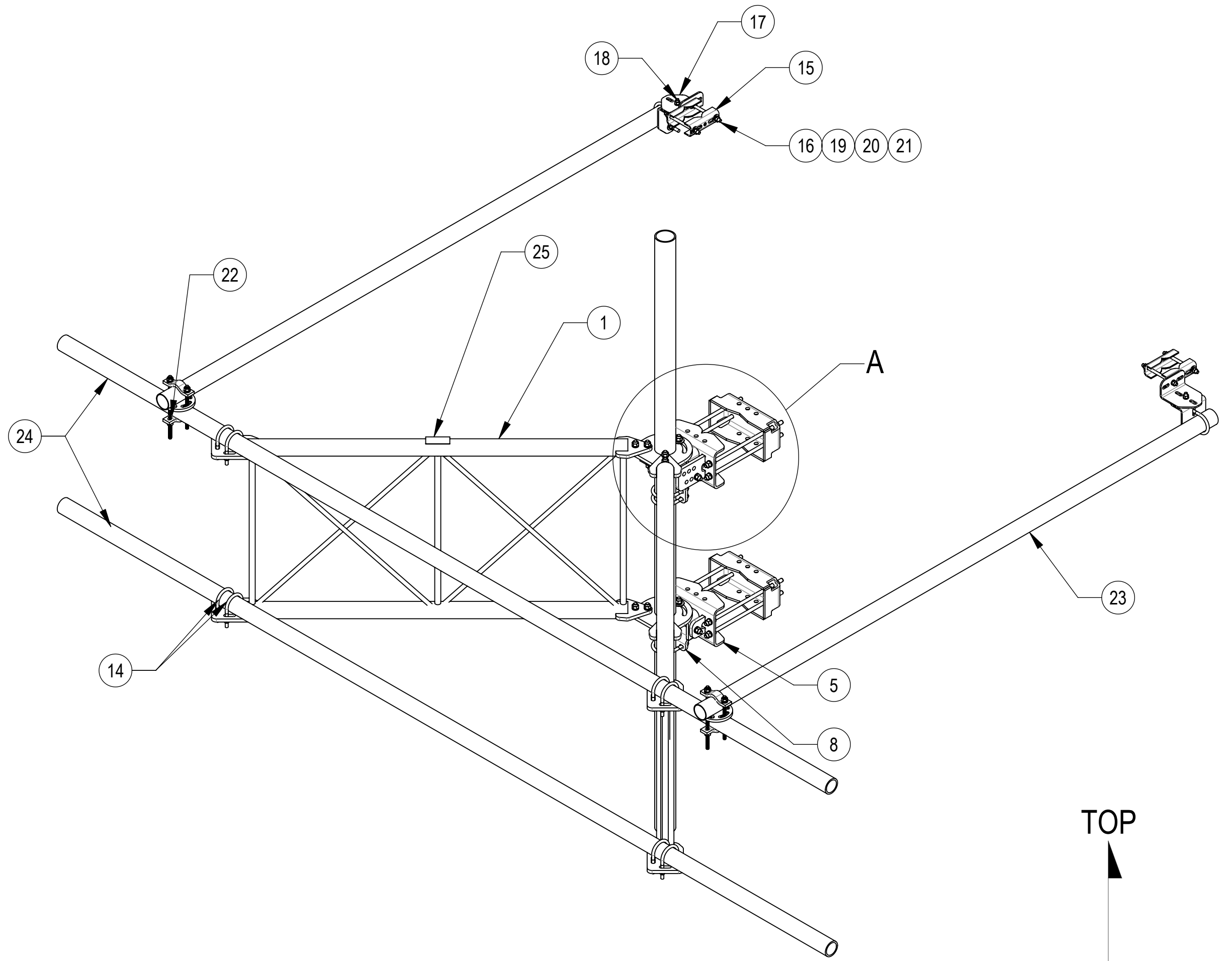

ALLOWABLE TIEBACK ANGLE

+15 DEGREES VERTICAL
+25 DEGREES HORIZONTAL

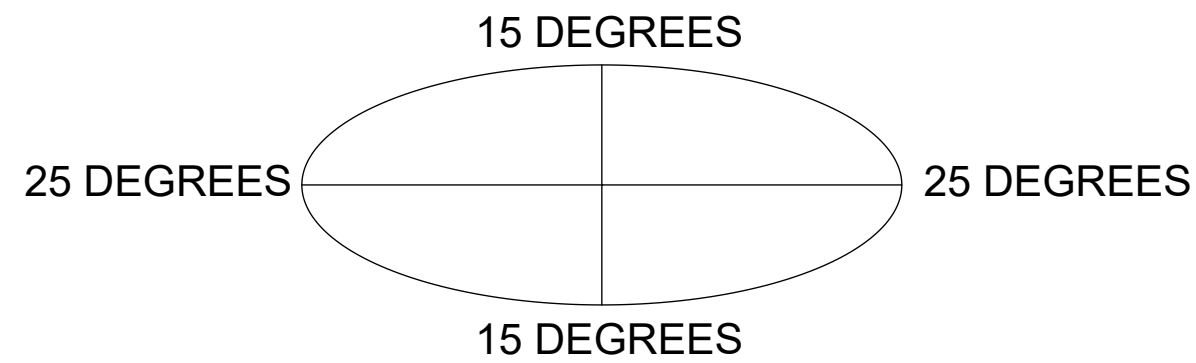

COMPONENT PART NUMBERS PROVIDED FOR ASSEMBLY PURPOSES;
INDIVIDUAL COMPONENTS MAY BE SHIPPED AS PARTS WITHIN AN INCLUDED KIT.

ITEM	PART NO.	DESCRIPTION	QTY.	WEIGHT	NOTE NO.
1	SFG23180-00	ARM, STANDOFF, SFG23	2	120.07 LBS	
2	SFG2204	WELDMENT, BACK VERTICAL ARM MOUNT	1	97.29 LBS	
3	GB-05225	5/8" X 2-1/4" GALV BOLT KIT	14	0.28 LBS	
4	SFG2380	WELDMENT, HD, TOP TAPER BRACKET	1	22.78 LBS	
5	SFG2381	WELDMENT, HD, LOWER TOWER LEG BRACKET	1	17.42 LBS	
6	SFG2289	G2 RRU BACK CLAMP, HD	2	18.65 LBS	
7	SFG2386	WELDMENT, SFG2 AZIMUTH BRACKET	1	10.69 LBS	
8	SFG2397-00	WELDMENT, G23 AZIMUTH BRACKET	1	8.56 LBS	
9	MT-382-18	5/8" X 18" THREADED ROD	8	1.43 LBS	
10	GWL-05	5/8" GALV LOCK WASHER	16	0.03 LBS	
11	GN-05	5/8" GALV HEX NUT	24	0.08 LBS	
12	GUB-4355	1/2" X 3-5/8" X 5" GALV U-BOLT	3	0.71 LBS	
13	GWF-05	5/8" GALV FLAT WASHER, 1.7OD	2	0.06 LBS	
14	GUB-4352	1/2" X 3" X 5-1/4" GALV U-BOLT	10	0.71 LBS	
15	SAB01	FORMED CLAMP	4	1.35 LBS	
16	MT-379-8	1/2" X 8" GALV THREADED ROD	4	0.45 LBS	
17	XAU01	ANGLE, CROSSOVER, 1.9-3.5" X 1.9-3.5" OD	4	2.98 LBS	
18	GB-04145	1/2" X 1-1/2" GALV BOLT KIT	2	0.13 LBS	
19	GWF-04	1/2" GALV FLAT WASHER	8	0.04 LBS	
20	GWL-04	1/2" GALV LOCK WASHER	10	0.01 LBS	
21	GN-04	1/2" GALV HEX NUT	10	0.04 LBS	
22	XP-R	CROSSOVER PLATE, ROUND, UP TO 3.5" OD	2	6.20 LBS	
23	MT546120120	PIPE, 2.875"OD X 120"	2	35.44 LBS	
24	MT546180276	PIPE, 2.875"OD X 180"	2	115.33 LBS	
25	SFG23100	LABEL, SFG23RHDXL	1	0.04 LBS	

COMMSCOPE, INC. OF NORTH CAROLINA

TITLE		SF,15',BASE-KIT		
SIZE	SCALE	DOCUMENT NO.		
C	1:16	SFG23RHDXL-15-B		
DRAWING		SHEET		
VERSION	STATUS	REVISION	2 OF 5	
00	RE	A		

© 2023 CommScope, Inc. Confidential

4

3

2

1

4

3

2

1

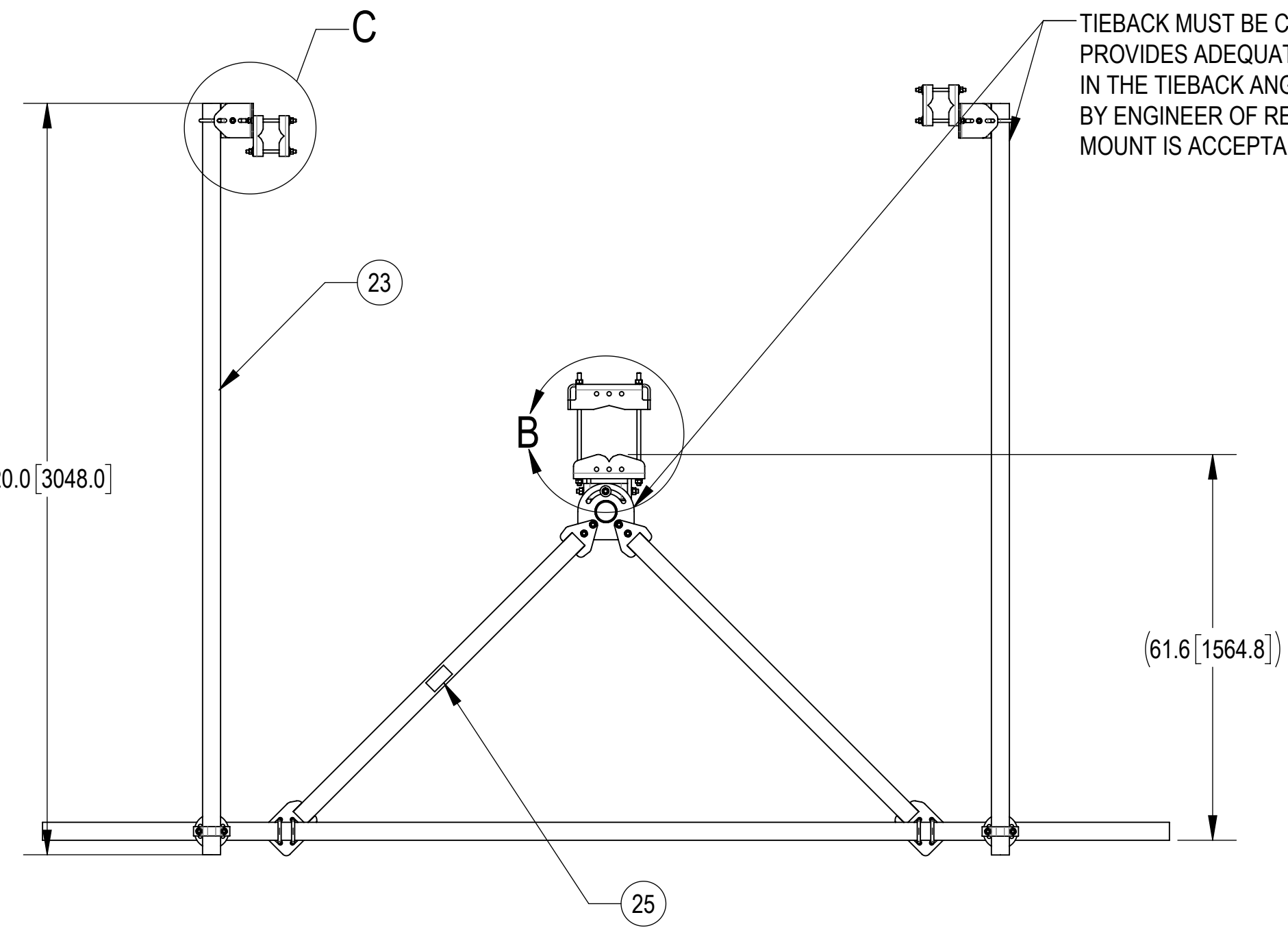

TIEBACK MUST BE CONNECTED TO A RIGID MEMBER THAT PROVIDES ADEQUATE SUPPORT WITHIN THE LIMITS NOTED IN THE TIEBACK ANGLE RANGE DETAIL. UNLESS APPROVED BY ENGINEER OF RECORD. SPINE STEM OF NEIGHBORING MOUNT IS ACCEPTABLE.

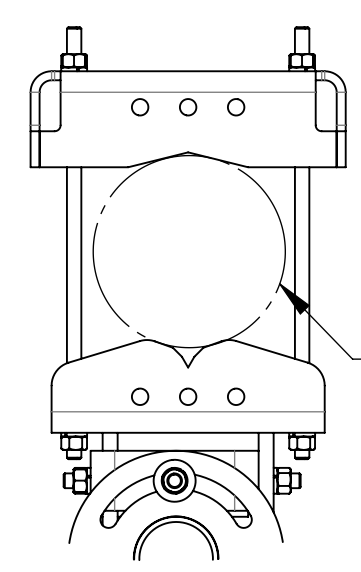

DETAIL B
SCALE 1 : 8

FOR POLES UP TO 8.0" IN DIAMETER

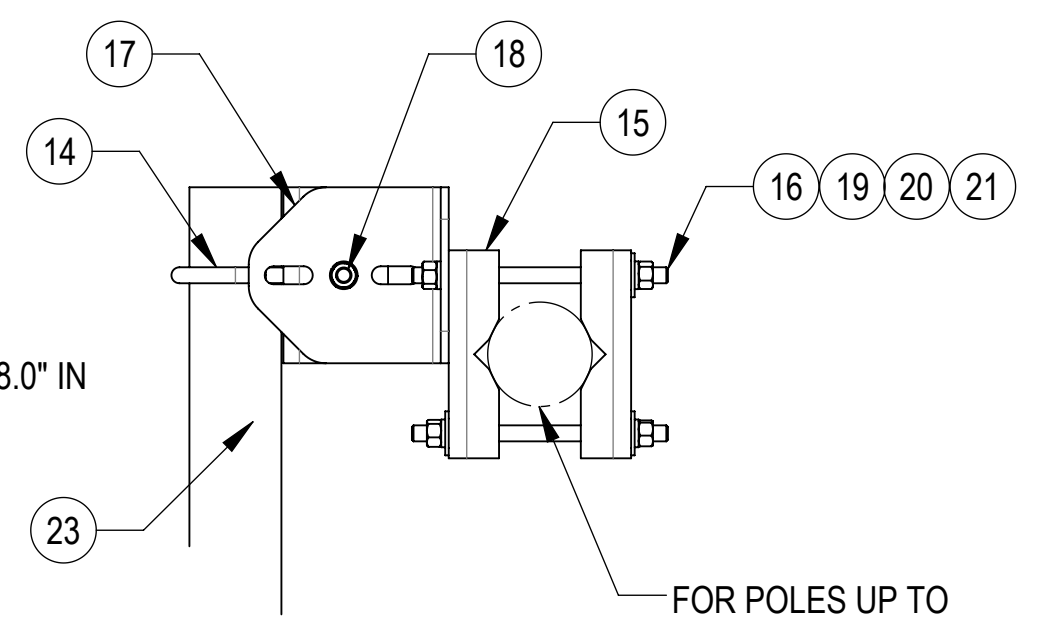

DETAIL C
SCALE 1 : 6

FOR POLES UP TO 3.25" IN DIAMETER

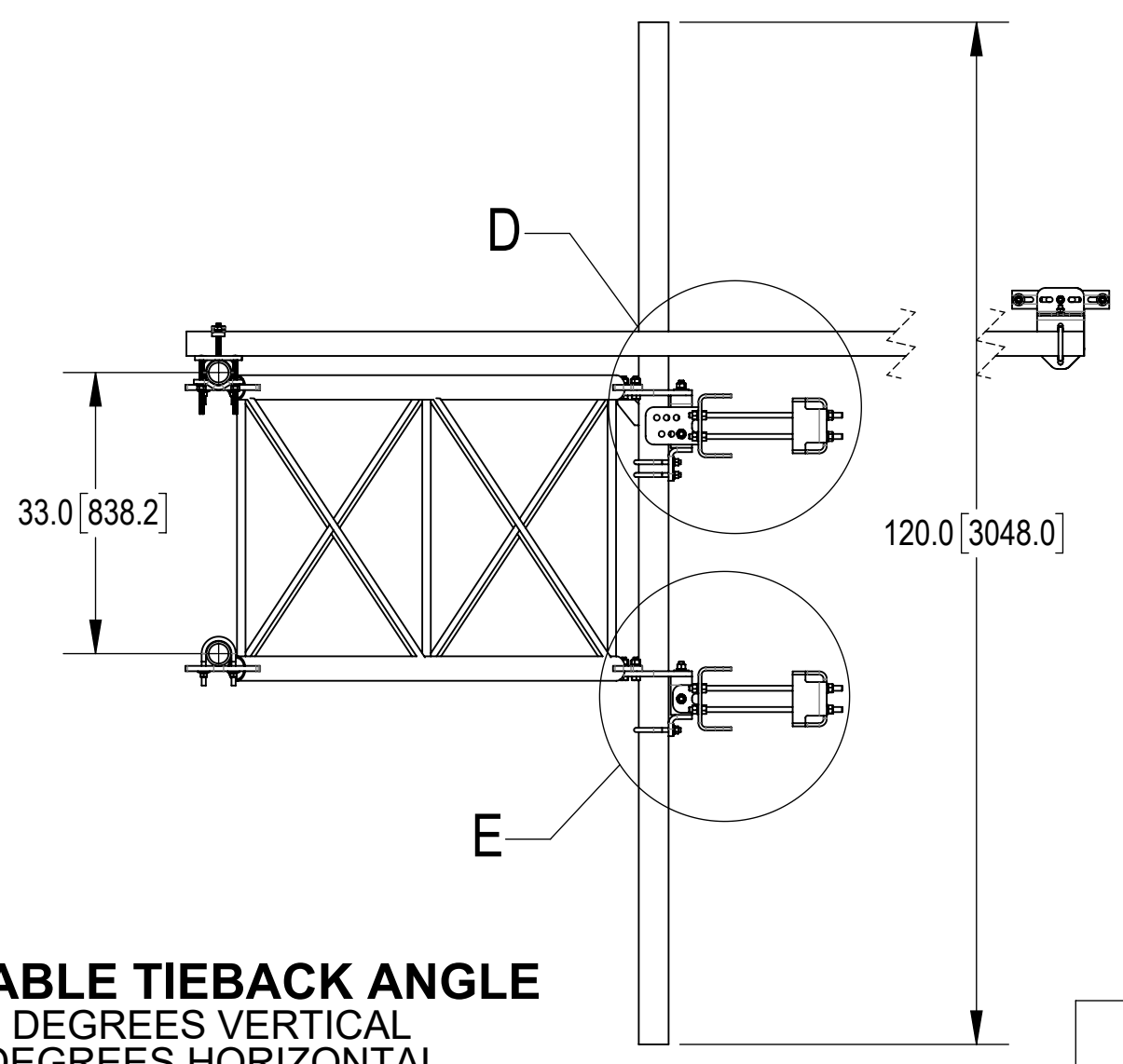
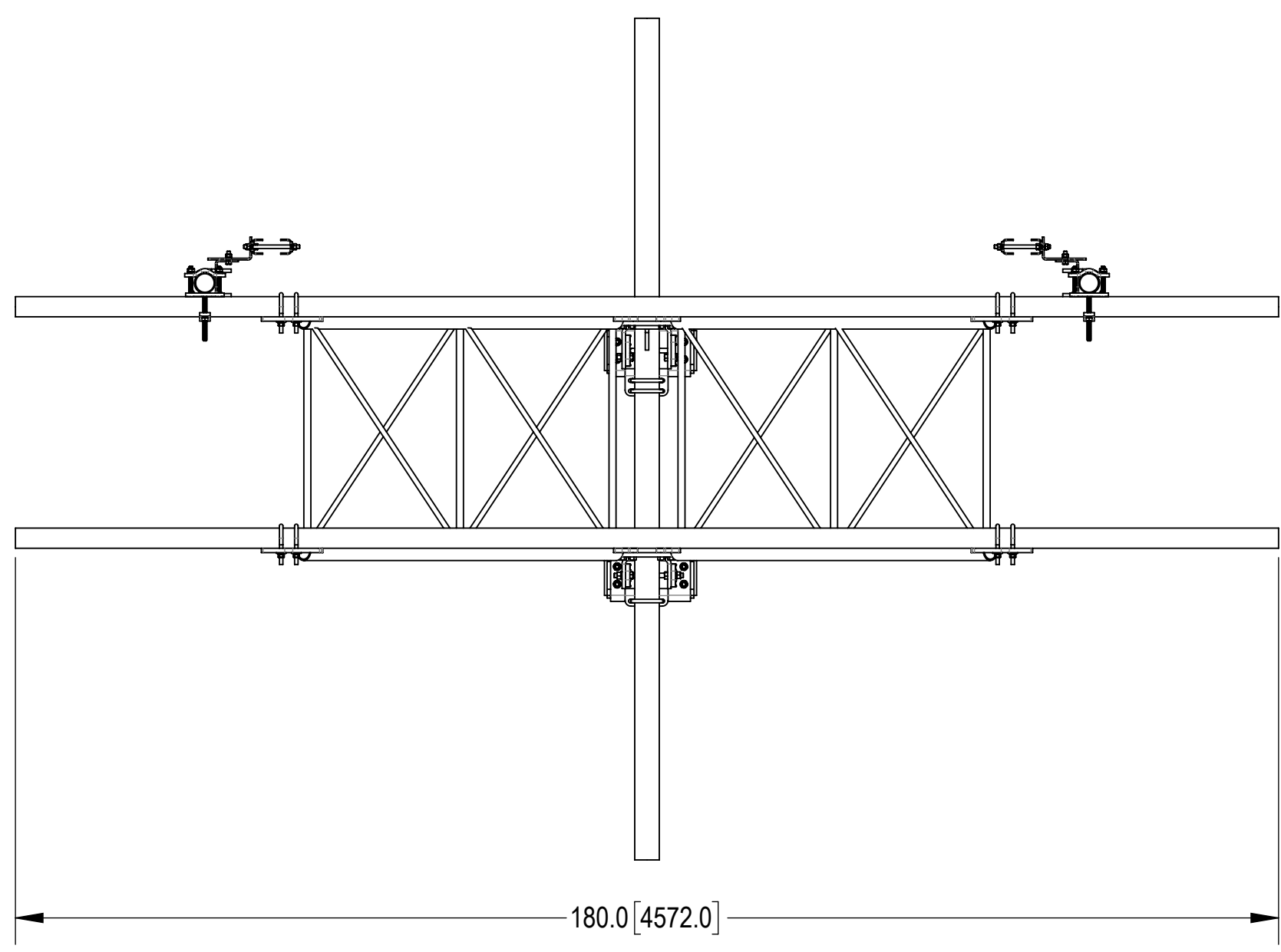

ALLOWABLE TIEBACK ANGLE
+15 DEGREES VERTICAL
±25 DEGREES HORIZONTAL

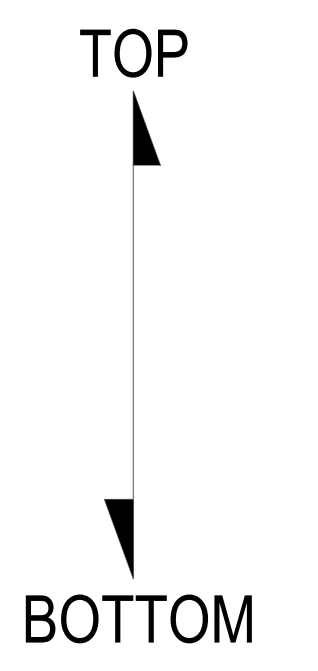
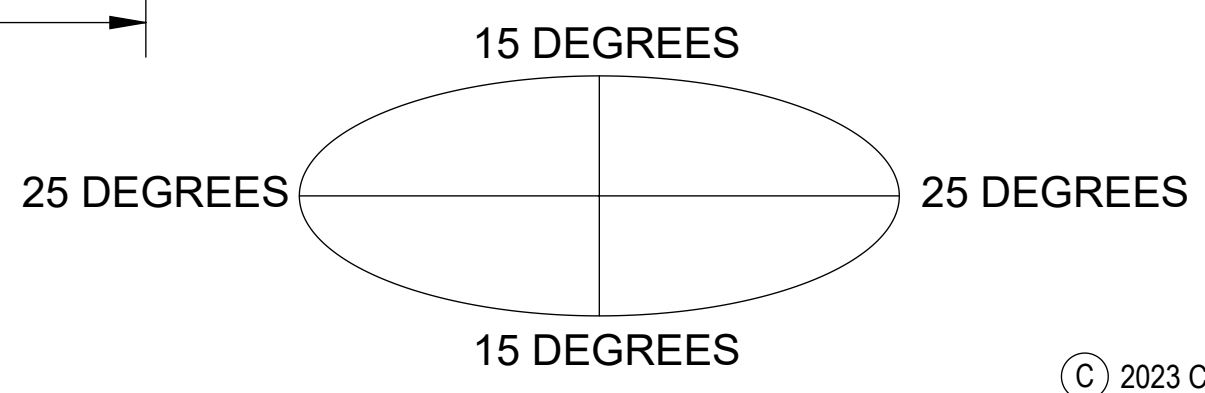

COMMSCOPE, INC. OF NORTH CAROLINA				
TITLE				
SF, 15', BASE-KIT				
SIZE	SCALE	DOCUMENT NO.		
C	1:21	SFG23RHDXL-15-B		
		DRAWING		SHEET
		VERSION	STATUS	REVISION
		00	RE	A
				3 OF 5

4

3

2

1

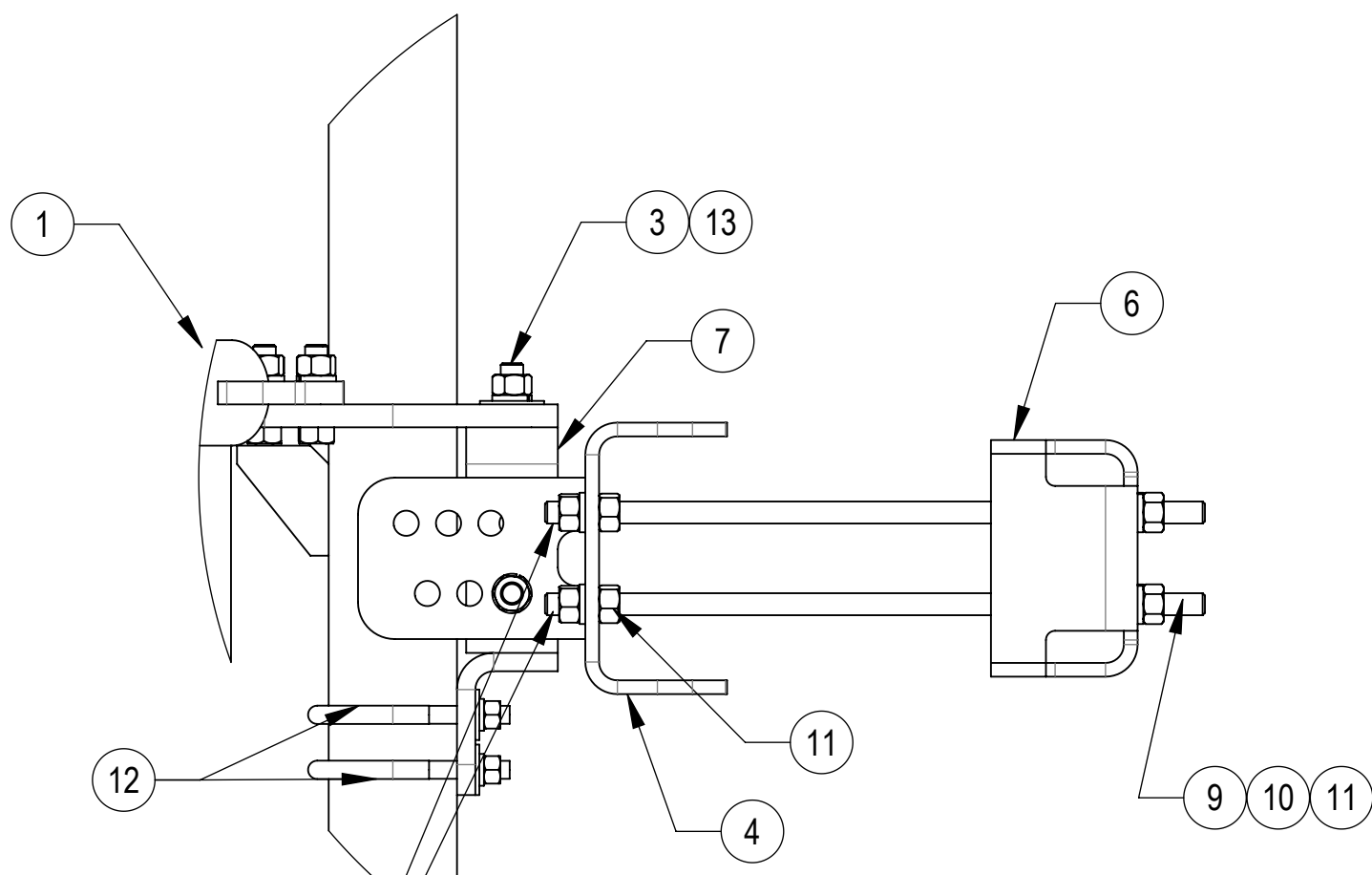

DETAIL D
SCALE 1 : 5

THE THREADED ROD CAN ONLY EXPOSE 4 TO 7 THREADS ON ONE SIDE OF THE BRACKET, WHICH IS TO PREVENT INTERFERENCE WITH THE SIDE BOLTS

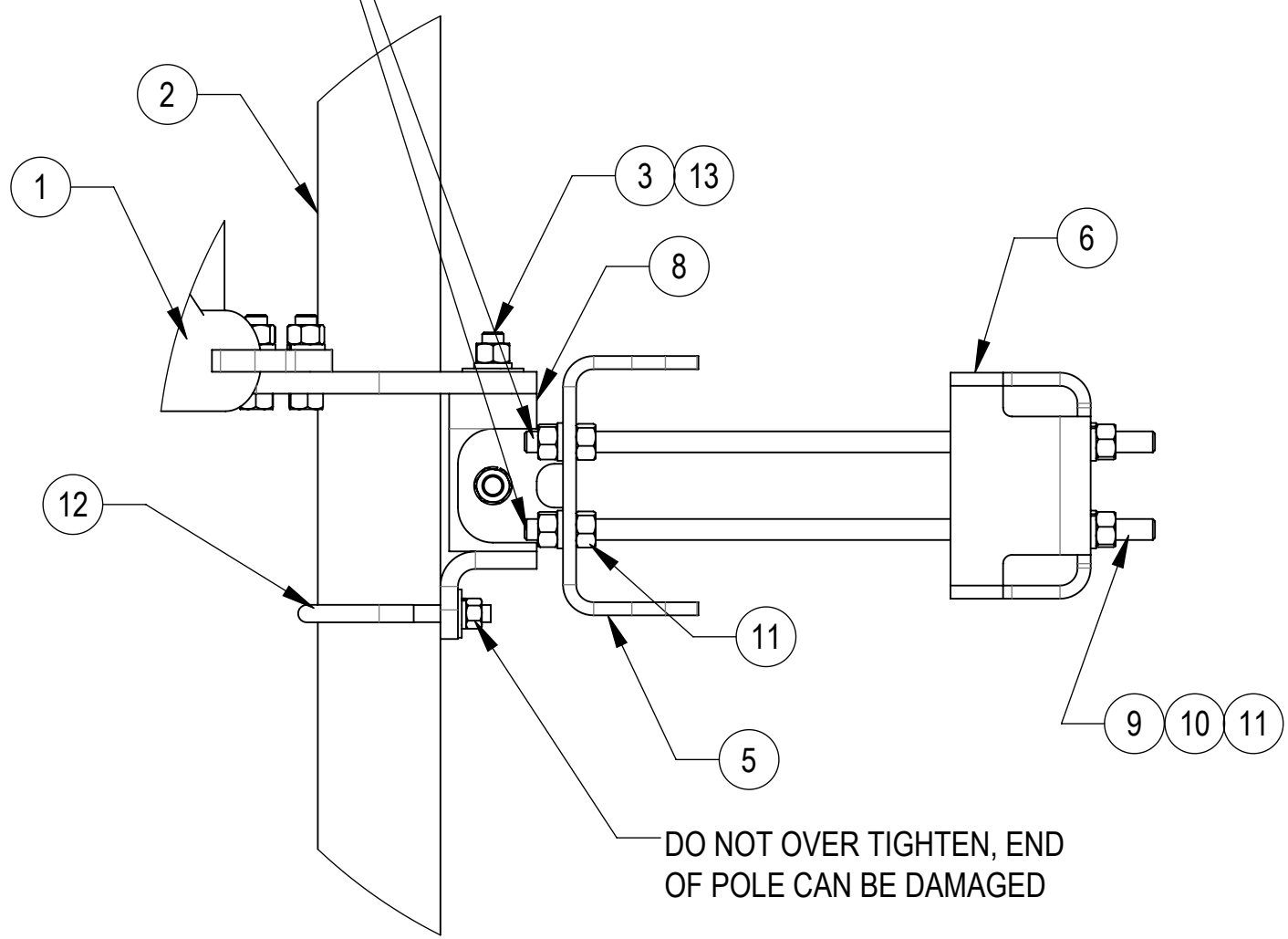

DETAIL E
SCALE 1 : 5

DO NOT OVER TIGHTEN, END OF POLE CAN BE DAMAGED

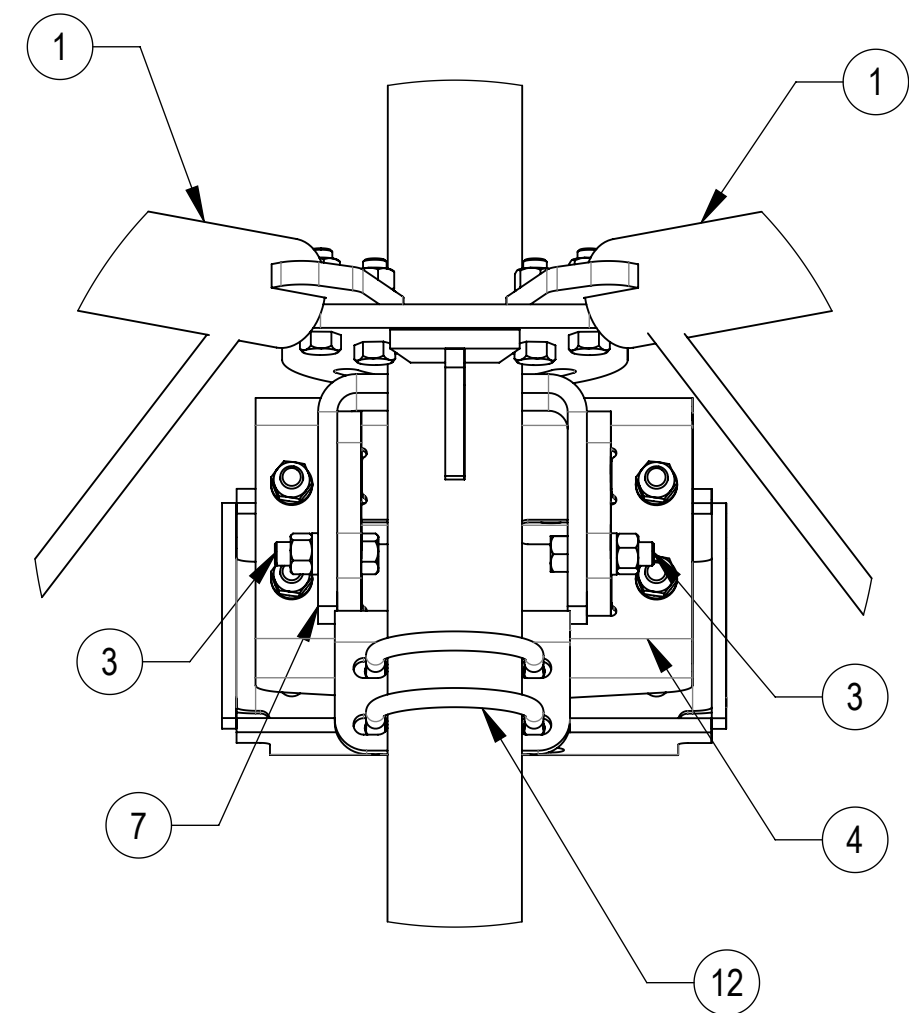

DETAIL ISO TOP ROTATED VIEW
SCALE 1 : 5

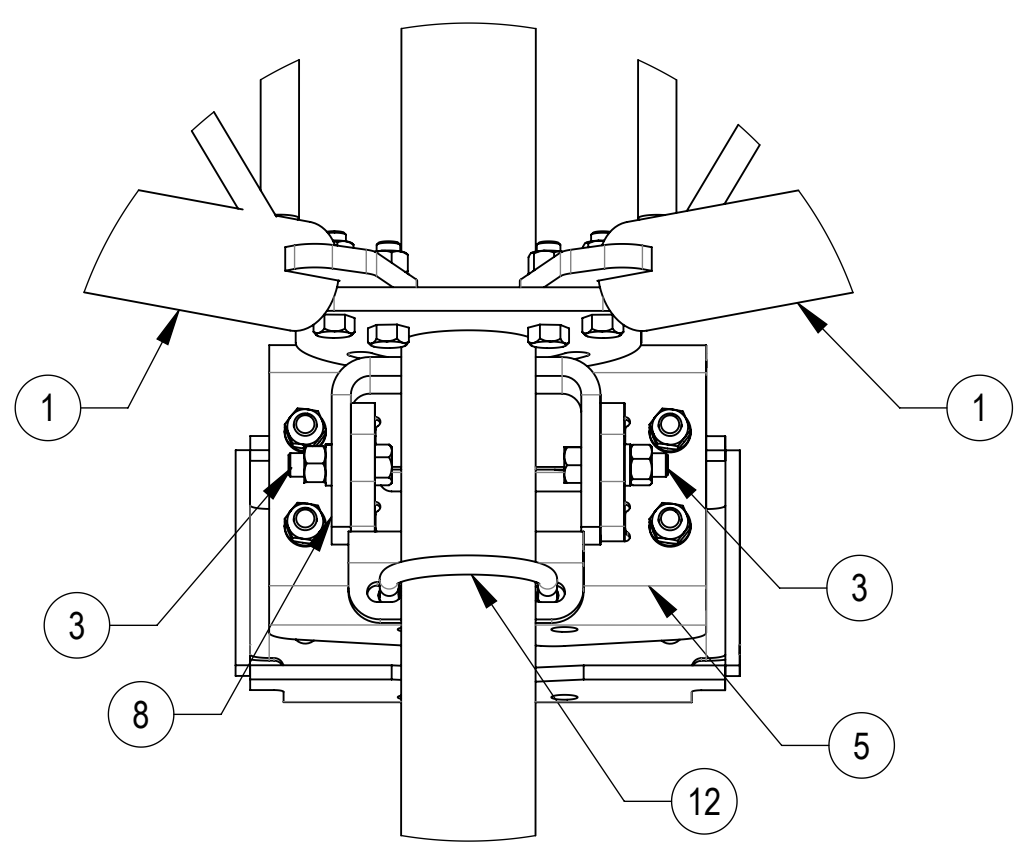

DETAIL ISO BOTTOM ROTATED VIEW
SCALE 1 : 5

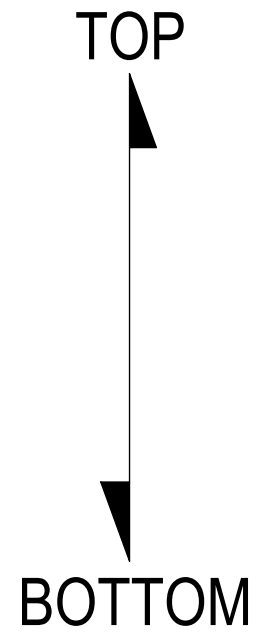

COMMSCOPE, INC. OF NORTH CAROLINA				
TITLE SF,15',BASE-KIT				
SIZE C	SCALE 1:21	DOCUMENT NO. SFG23RHDXL-15-B		
		DRAWING		SHEET
		VERSION	STATUS	REVISION
		00	RE	A
				4 OF 5

4

3

2

1

ACCESSORIES ORDERED SEPARATELY:

D

D

C

C

B

B

A

A

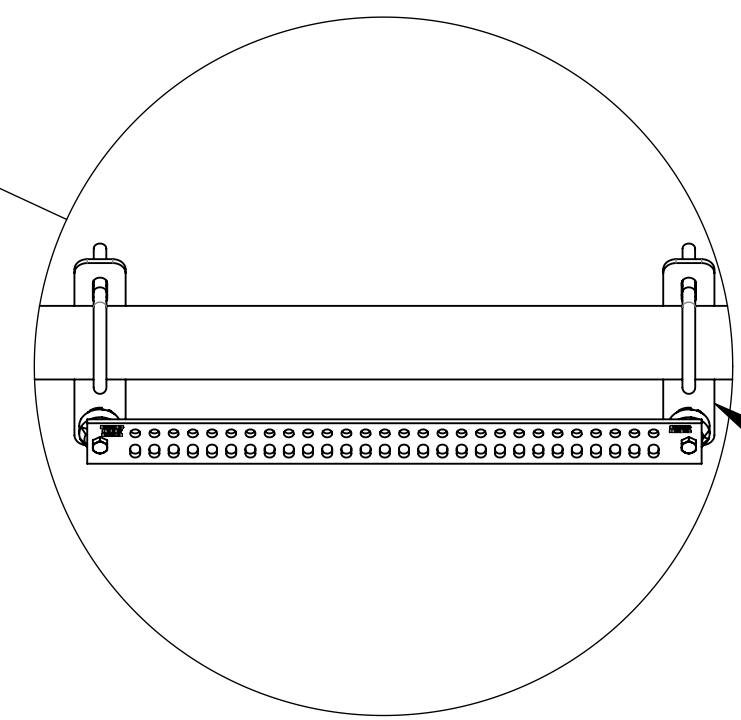
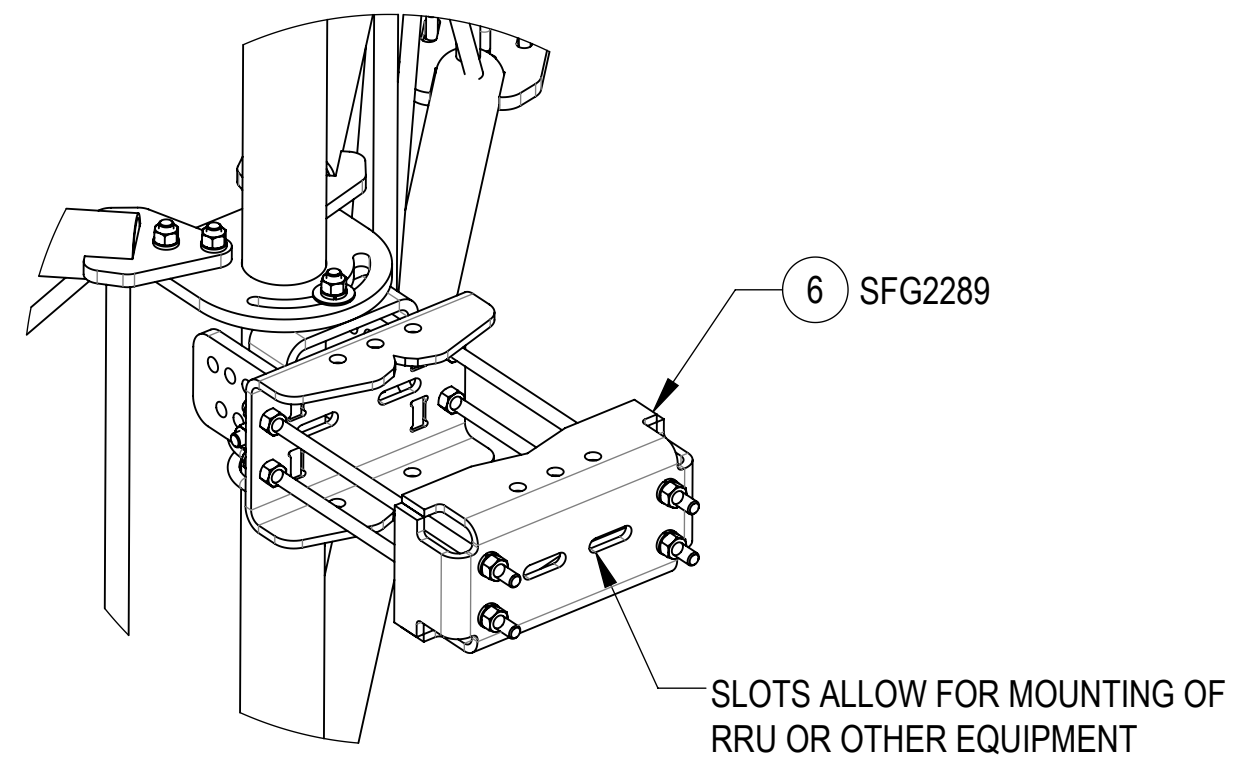
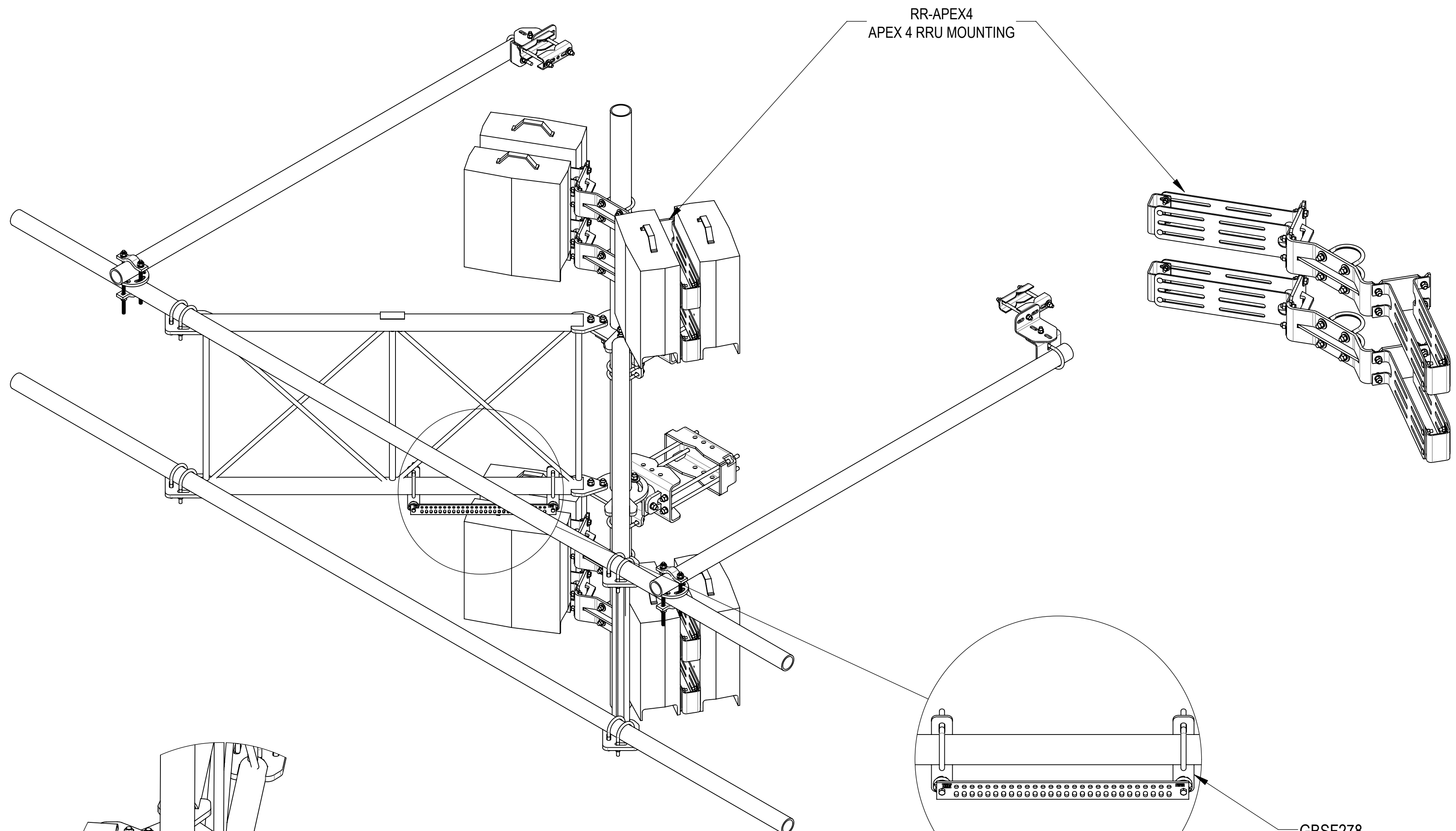

DETAIL N
SCALE 2 : 15

COMMSCOPE, INC. OF NORTH CAROLINA				
TITLE SF, 15', BASE-KIT				
SIZE C	SCALE 1:12	DOCUMENT NO. SFG23RHDXL-15-B		
		DRAWING		SHEET
		VERSION	STATUS	REVISION
		00	RE	A
				5 OF 5

4

3

2

1