

1.0 GENERAL NOTES

- 1.1 ALL METRIC DIMENSIONS ARE IN BRACKETS [X. X]
- 1.2 FOR PATENT INFO: <https://www.cs-pat.com>
- 2.0 DESIGN NOTES
  - 2.1 ANY HAZARDS OR OBSTRUCTIONS TO THE CLIMBING FACILITY AND SAFETY CLIMB MUST BE IDENTIFIED PRIOR TO INSTALLING THE APPURTENANCE. ADDITIONAL PRODUCTS MAY BE REQUIRED TO MAINTAIN THE INTEGRITY OF THE SAFETY CLIMB. DURING INSTALLATION, TEMPORARY AND/OR PERMANENT PRECAUTIONARY MEASURES SHOULD BE TAKEN TO PRESERVE THE CLIMBING FACILITY AND/OR SAFETY CLIMB.
  - 2.2 FITS MONOPOLES 15"-45" O.D.
  - 2.3 ANTENNA PIPES SHOULD BE CENTERED AND EVENLY SPACED.
  - 2.4 POSITION MOUNT OR ADJUST SAFETY CLIMB CABLE SO NOT TO HINDER OR DAMAGE OR OBSTRUCT THE SAFETY CLIMB. SAFETY CABLE ROUTING BRACKET MAY BE PURCHASED SEPARATELY.
- 3.0 MANUFACTURING/SPECIAL REQUIREMENTS
  - 3.1 TIGHTEN ALL BOLTS SECURING FLAT PLATES BY THE TURN-OF-NUT METHOD. TIGHTEN ALL U-BOLTS USING TURN-OF-NUT METHOD WITH ATTENTION TO LEAVE EQUAL DISTANCE AND EQUAL FORCE ON EACH LEG OF THE U-BOLT. ALL FASTENERS SHOULD BE TIGHTENED PER AISC 6.5.2.
  - 3.2 SUGGEST PRE-ASSEMBLE MINI KICKER BRACKET TO RING MOUNT ON THE GROUND.
- 4.0 TEST
- 5.0 PACKAGING
  - 5.1 PACKAGING SHALL MEET COMMSCOPE REQUIREMENTS PER DOCUMENT IS-PL-3005
  - 5.2 PRINTED DOCUMENT TO BE PLACED INSIDE POLYBAG AND THEN IN SHIPPING CONTAINER
  - 5.3 EXTRA HARDWARE MAY BE SUPPLIED, BAGGED AND SHIPPED

REVISIONS			
REV.	DESCRIPTION	DATE	APPROVED
A	INITIAL RELEASE		

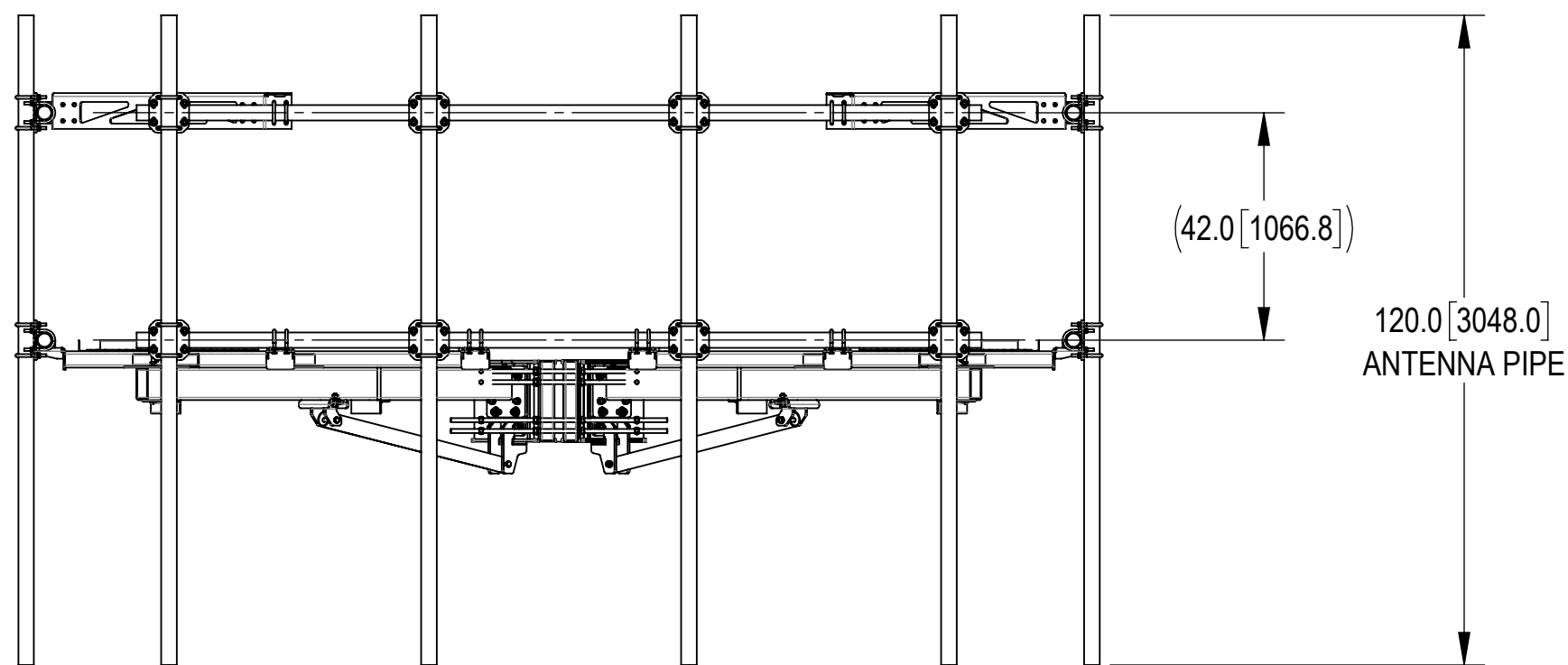
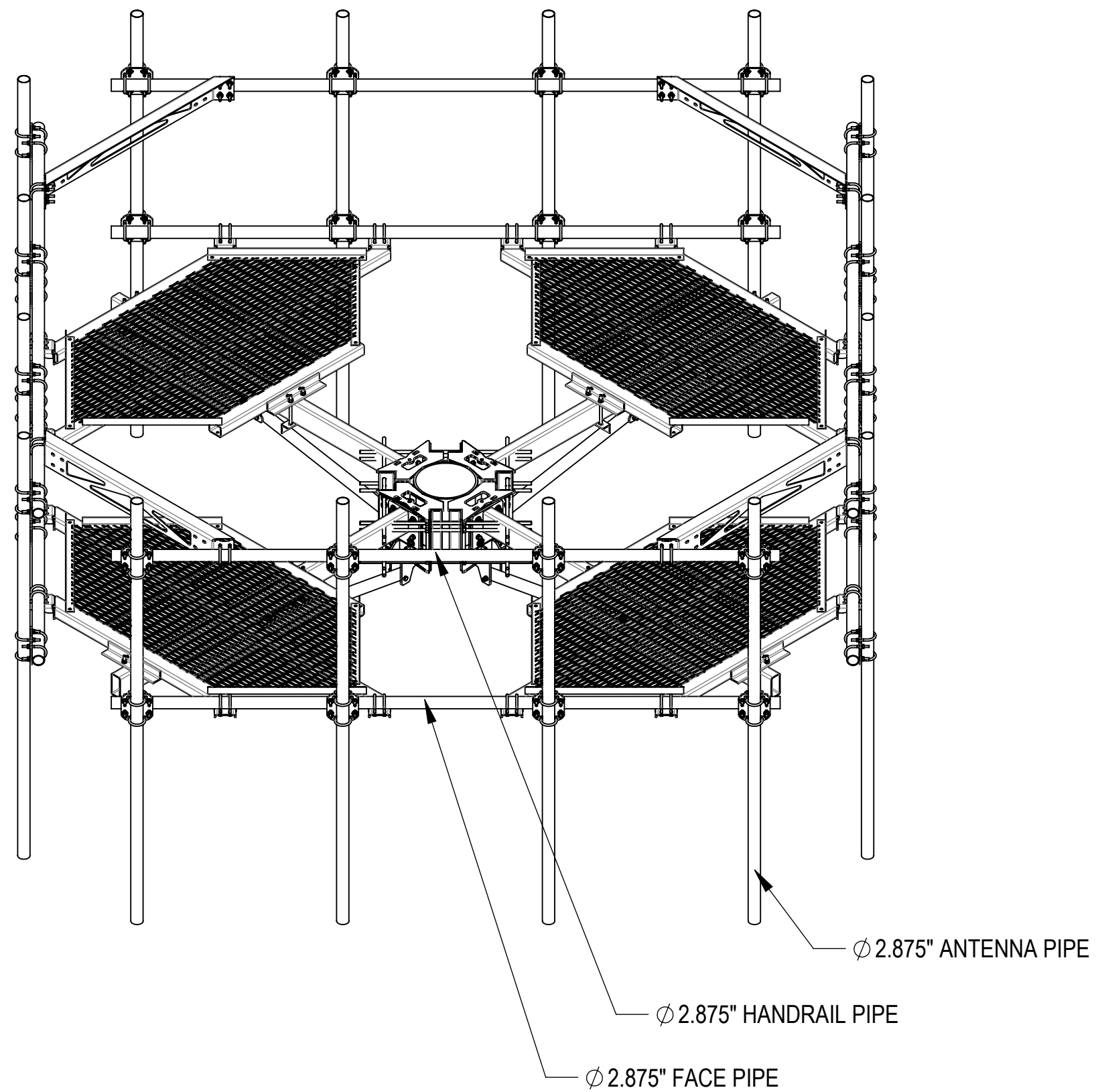
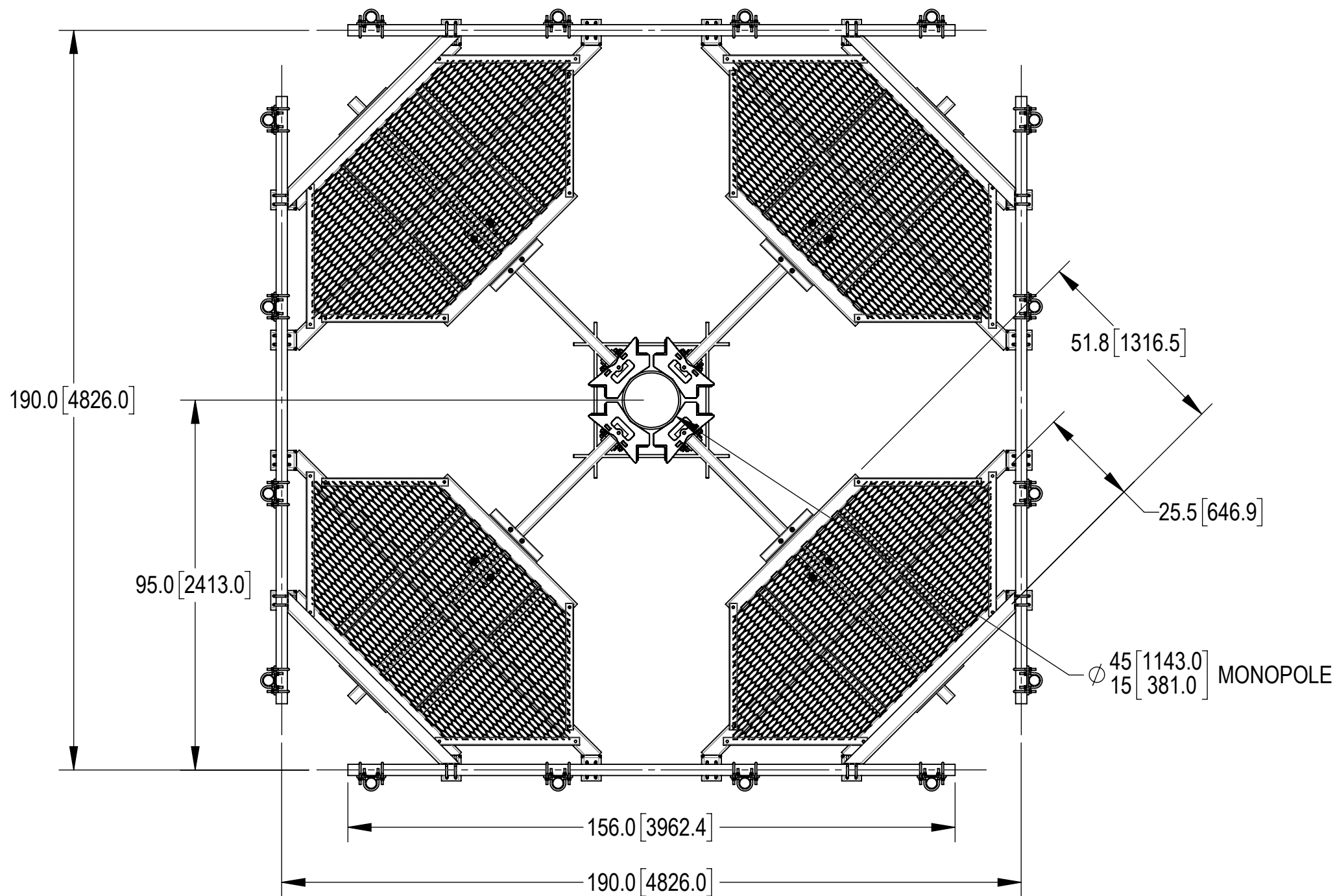

DENSITY	5079.20	lbs/in <sup>3</sup>
MASS	5079.20	lbs
VOLUME	19370.24	in <sup>3</sup>
SURFACE AREA	169342.67	in <sup>2</sup>
HEIGHT	120.0"	
LENGTH	156.0"	
WIDTH	156.0"	

**COMMSCOPE, INC. OF NORTH CAROLINA**

TOLERANCES		SAP MATERIAL MASTER	
1 PLACE .X[X] ± 0.2[6.3]	3 PLACE .XXX[X] ± 0.060[1.5]	<b>MP-PP13M4-16C-120</b>	
2 PLACE .XX[X] ± 0.12[3.0]	ANGLES ± 2°		
FINISH		MATERIAL	
<small>UNLESS OTHERWISE SPECIFIED DIMENSIONS ARE IN INCHES INTERPRET PER ANSI Y 14.5M-1994</small>		NAME	DATE
		CE JL1183	24APR24
		RW	
		AD	
		RE	
ECN		<b>MP, 13', 4S, (16) 2.88" X 120" PIPE, W/HR</b>	
SIZE	Auth Group	SCALE	DOCUMENT NO.
<b>C</b>		<b>1:32</b>	<b>MP-PP13M4-16C-120</b>
MODEL		DRAWING	
VERSION	STATUS	REVISION	VERSION
01			
			SHEET
			1 OF 9

# PART NUMBERS, WEIGHTS, & EPA

TABLE 1: CONFIGURATIONS

PART NUMBER	DESCRIPTION	WEIGHT (LBS)	(EPA)A (FT^2)*	(EPA)A 1/2" ICE THICKNESS (FT^2)*	ANTENNA PIPES	INCLUDED PARTS							
						MC-RMHD-1245-3	MC-AS-SB04	RK-48-3MK	MPPP-HK02	MT546156	HRK-13-12-4M	XP-2525-8	MT546120120
MP-PP13M4-16C-120	MP,13',4S,(16)2.88"X120"PIPE,W/HR	5079.2	50.53	64.18	16	1	1	1	4	1	4	16	

\* (EPA)A DOES NOT INCLUDE ANTENNA PIPES AND MOUNTING HARDWARE. IF DESIRED, ADD ANTENNA PIPE PER TABLE 2



TABLE 2: EPA OF EACH ANTENNA PIPE

ANTENNA PIPE	(EPA)A (FT^2)	(EPA)A W/ 1/2" ICE THICKNESS (FT^2)
2-7/8" X 120"	2.30	3.10

NOTE:

1. ANTENNA PIPES ARE CONSIDERED SEPARATELY.
2. KA FACTOR OF 4-SECTOR EPA INCLUDED.
3. COMBINE THE ASSOCIATED EPA VALUES IN THE TABLES ABOVE TO DETERMINE THE EPA OF A MOUNT MODEL WITH A LISTED MOUNT PIPE CONFIGURATION.  
FOR EXAMPLE, MP-PP13M4-16C-120 HAS A 4-SECTOR EPA OF 50.53 FT2 WITH NO ICE PLUS 16 ANTENNA PIPES WITH A 4-SECTOR EPA OF 16X2.30=36.80 FT2 WITH NO ICE. SO, THE TOTAL EPA OF 87.33 FT2 FOR THE MP-PP13M4-16C-120.

COMMSCOPE, INC. OF NORTH CAROLINA

TITLE				
SIZE <b>C</b>	SCALE <b>1:32</b>	DOCUMENT NO.		
 		DRAWING		SHEET 2 OF 9
		VERSION	STATUS	

# PLATFORM FOR INSTALLATION

ADJUST THE INSTALLATION DISTANCE ACCORDING TO THE DIAMETER OF THE MONOPOLE WHEN INSTALL PLATFORM MP-PP4-2000-00.  
SEE TABLE 3 DETAIL FOR THE DISTANCE ADJUSTED.

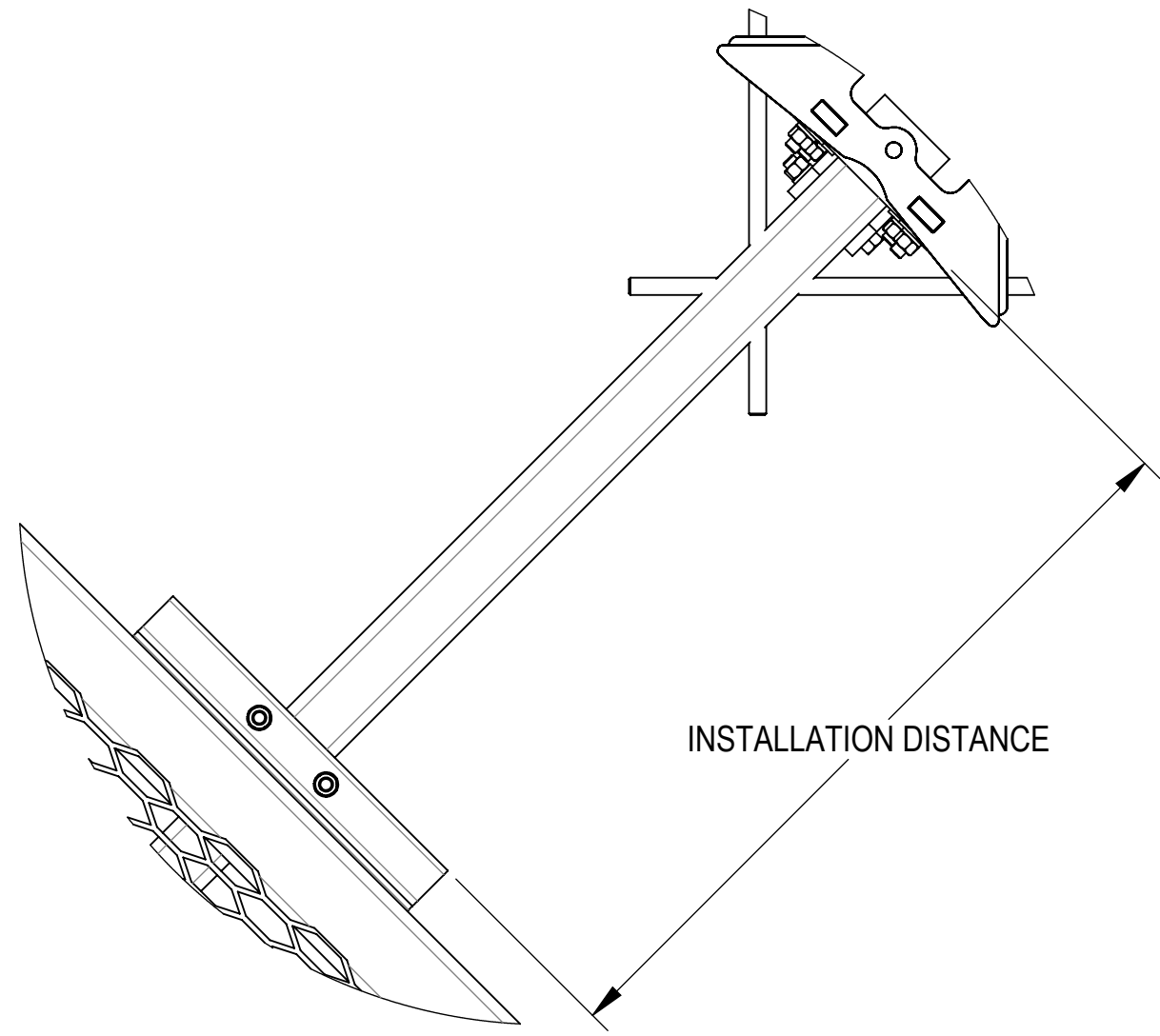

DETAIL A  
SCALE 1 : 8

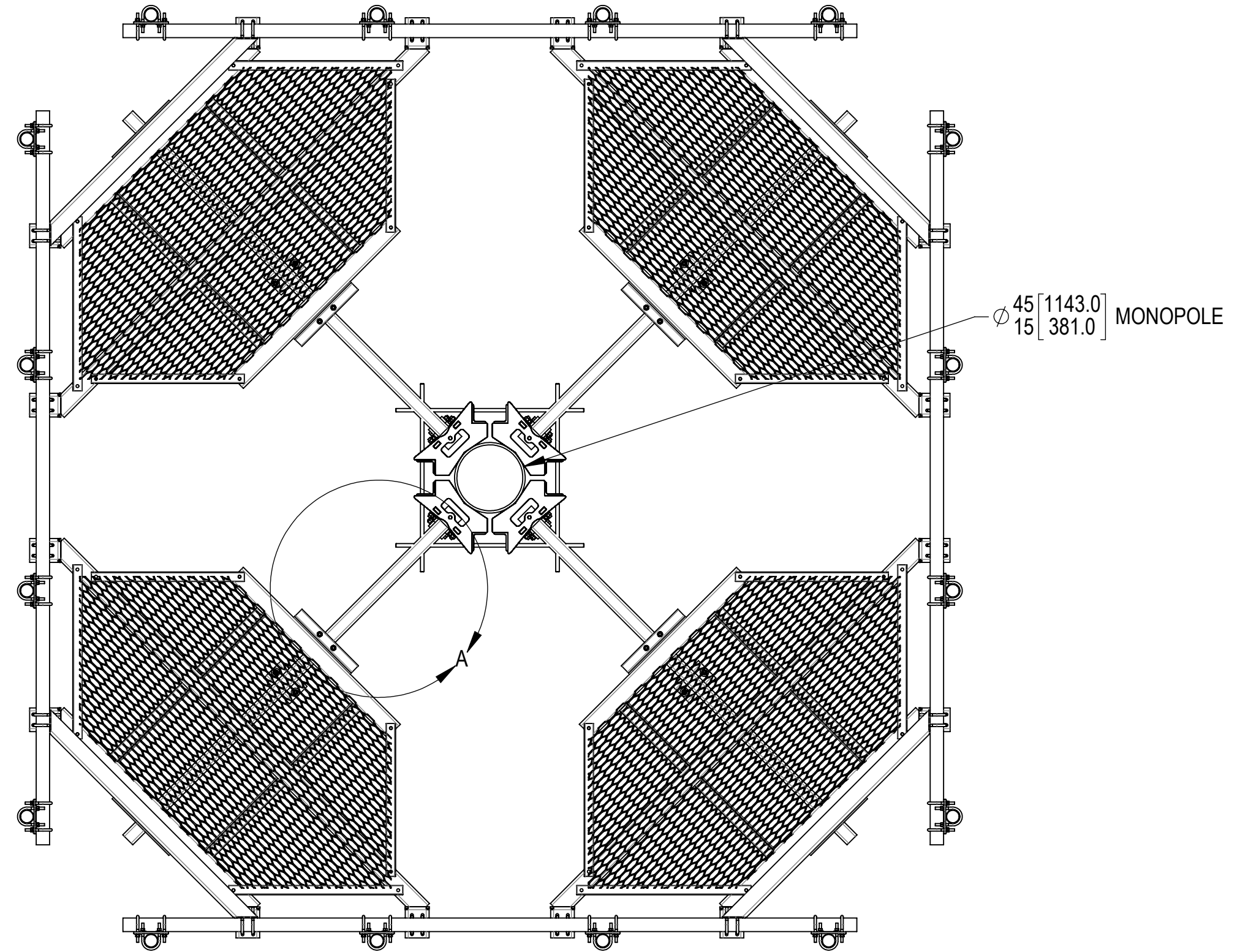
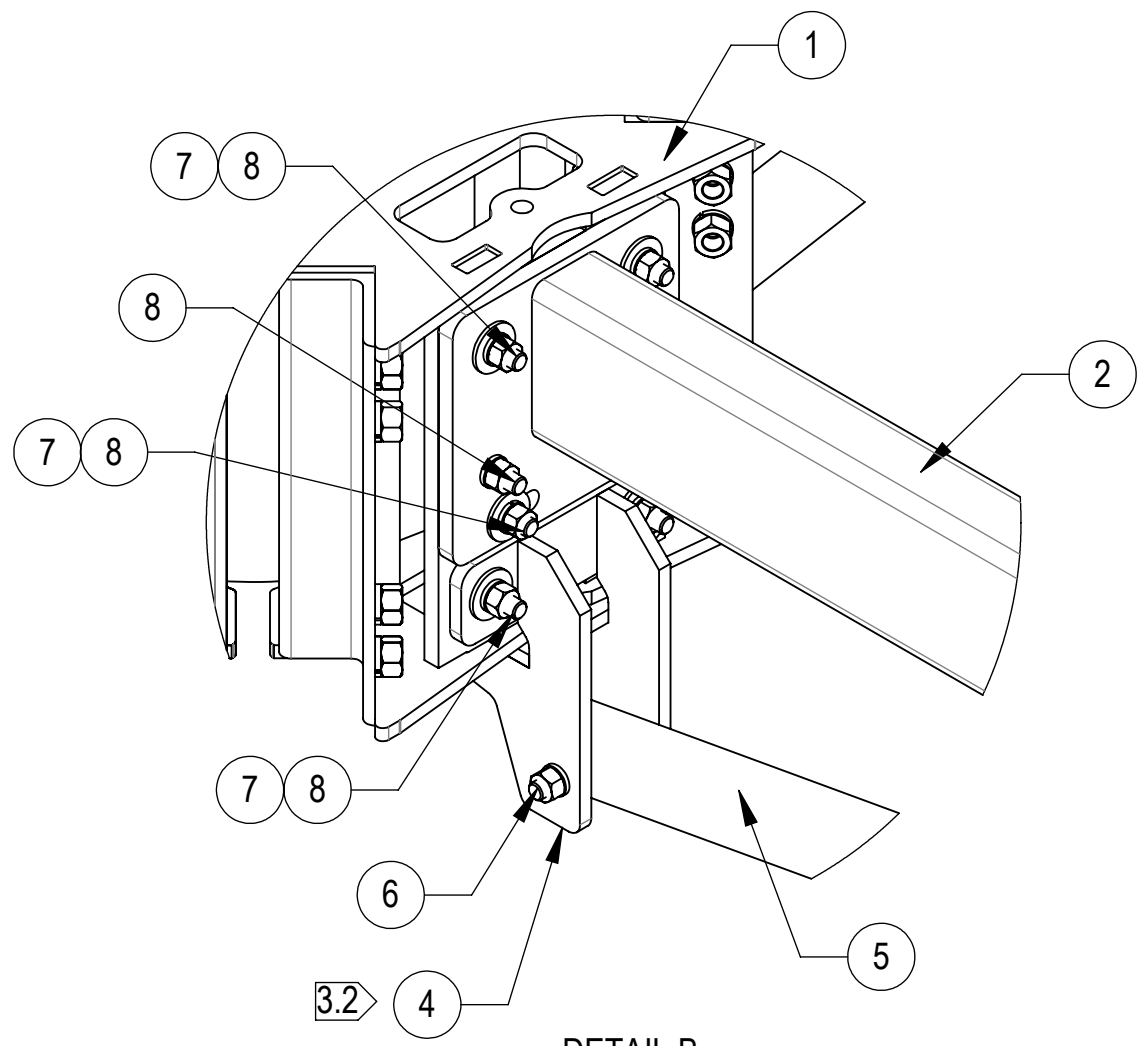

TABLE 3: PLATFORM INSTALLATION POSITION

DIAMETER OF MONOPOLE (INCH)	DISATNCE (INCH)	DIAMETER OF MONOPOLE (MM)	DISATNCE (MM)
15.0	34.16	381.0	867.66
17.5	32.89	444.5	835.28
20.0	31.61	508.0	802.89
22.5	30.34	571.5	770.51
25.0	29.06	635.0	738.12
27.5	27.79	698.5	705.74
30.0	26.51	762.0	673.35
32.5	25.24	825.5	640.97
35.0	23.96	889.0	608.58
37.5	22.69	952.5	576.20
40.0	21.41	1016.0	543.81
42.5	20.14	1079.5	511.43
45.0	18.86	1143.0	479.04

NOTE: FOR MONOPOLE DIAMETERS THAT ARE NOT IN THE TABLE, USE BELOW FORMULA TO GET THE VALUE OF THE ADJUSTMENT:  
DISTANCE OF ADJUSTMENT = 41.81-0.51\*D (INCH), WHERE D(INCH) IS THE DIAMETER OF MONOPOLE

COMMSCOPE, INC. OF NORTH CAROLINA			
TITLE			
SIZE <b>C</b>	SCALE <b>1:23</b>	DOCUMENT NO.	
DRAWING		SHEET	
VERSION	STATUS	REVISION	3 OF 9



DETAIL B  
SCALE 1 : 6

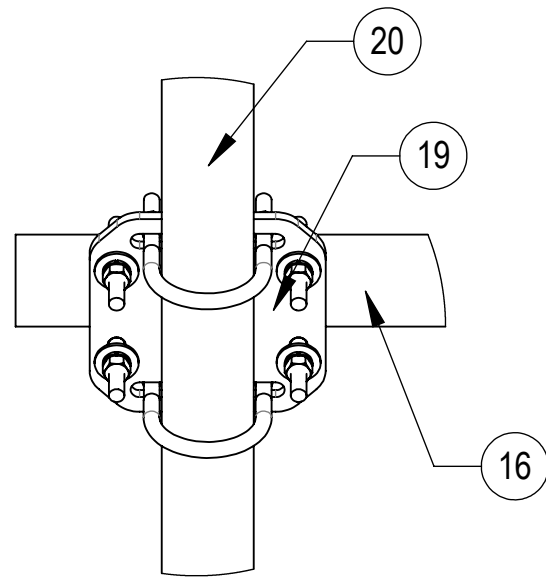

DETAIL F  
SCALE 1 : 6

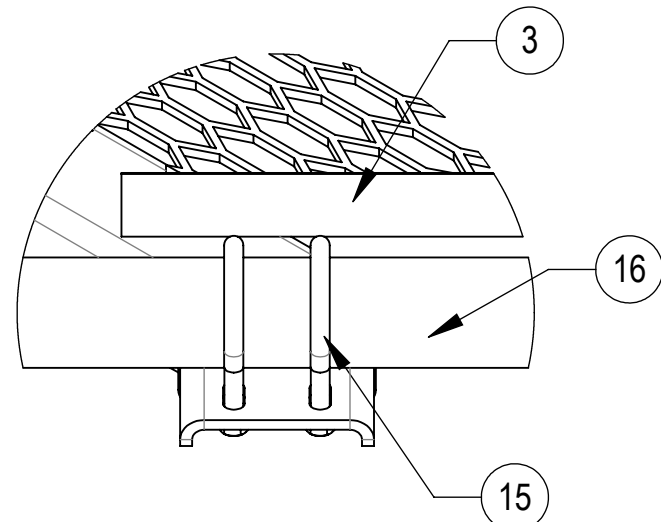

DETAIL H  
SCALE 1 : 5

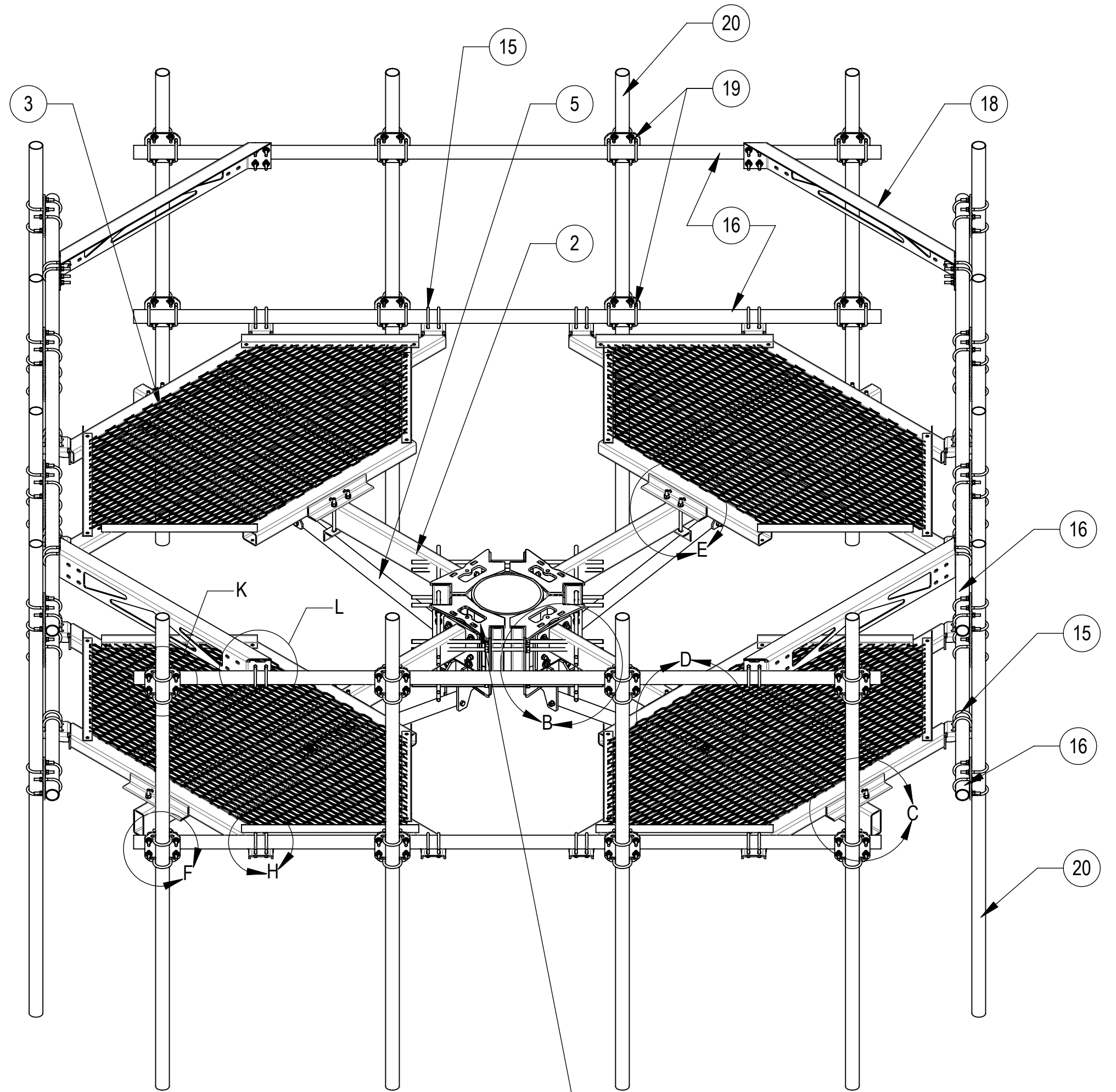

1 THREADED ROD  
FIELD TRIM AS NEEDED

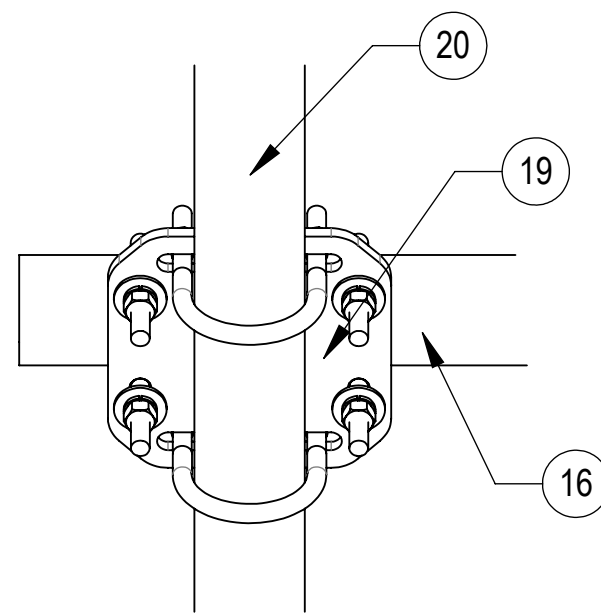

DETAIL K  
SCALE 1 : 5

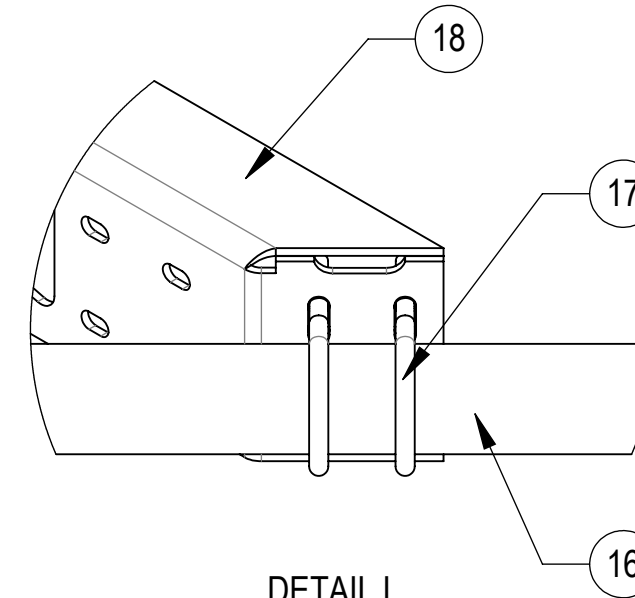

DETAIL L  
SCALE 1 : 5

COMPONENT PART NUMBERS PROVIDED FOR ASSEMBLY PURPOSES;  
INDIVIDUAL COMPONENTS MAY BE SHIPPED AS PARTS WITHIN AN INCLUDED KIT.

ITEM NO.	PART NUMBER	DESCRIPTION	QTY.	WEIGHT
1	MC-RMHD-1545-4	4 SECTOR RING MOUNT, 15"-45" POLE	4	386.57LBS
2	MP-PP4-1000-00	BARE SUB-WELDMENT, HD MONOPOLE PLATFORM	4	129.74 LBS
3	MP-PP4-2000-00	WELDMENT, CO-LOCATION PLATFORM	4	292.57 LBS
4	MC-AS-6100-00	WELDMENT, MINI KICKER BRACKET	4	14.77 LBS
5	RK48-00	MINI KICKER ARM SUPPORT TUBE 48"	4	22.96 LBS
6	GB-0550A	5/8" X 5" GALV BOLT KIT (A325)	8	0.52 LBS
7	GWF-05	5/8" GALV FLAT WASHER, 1.7OD	44	0.08 LBS
8	GB-0524A	5/8" X 2-1/2" GALV HEX BOLT (A325)	36	0.31 LBS
9	GB-0520A	5/8" X 2" GALV BOLT KIT (A325)	8	0.26 LBS
10	MC-AS-6400-00	WELDMENT, MINI KICKER CLIP	4	5.97 LBS
11	MC-AS-1200-00	CLAMP PLATE, CO-LOCATION PLATFORM	8	2.97 LBS
12	9615-14	BOLT,CARRIAGE,5/8-11,8.5,STL GALV	16	0.82 LBS
13	GWL-05	5/8" GALV LOCK WASHER	16	0.03 LBS
14	GN-05	5/8" GALV HEX NUT	16	0.08 LBS
15	GUB-4340	1/2" X 3" X 4" GALV U-BOLT	32	0.58 LBS
16	MT546156	2.875" O.D. X 156" PIPE	8	75.58 LBS
17	GUB-4352	1/2" X 3" X 5-1/4" GALV U-BOLT	16	0.71 LBS
18	MP-PP4-6000-00	CORNER WELDMEMT, HANDRAIL	4	34.20 LBS
19	XP-2525	CROSSOVER PLATE KIT, 2-7/8 OD X 2-7/8 OD	32	8.37 LBS
20	MT546120120	PIPE, 2.875"OD X 120"	16	35.44 LBS

(HIDDEN SOME PARTS FOR CLARITY)

COMMSCOPE, INC. OF NORTH CAROLINA				
TITLE				
SIZE <b>C</b>	SCALE <b>1:23</b>	DOCUMENT NO.		
DRAWING		SHEET		
VERSION	STATUS	REVISION	4 OF 9	

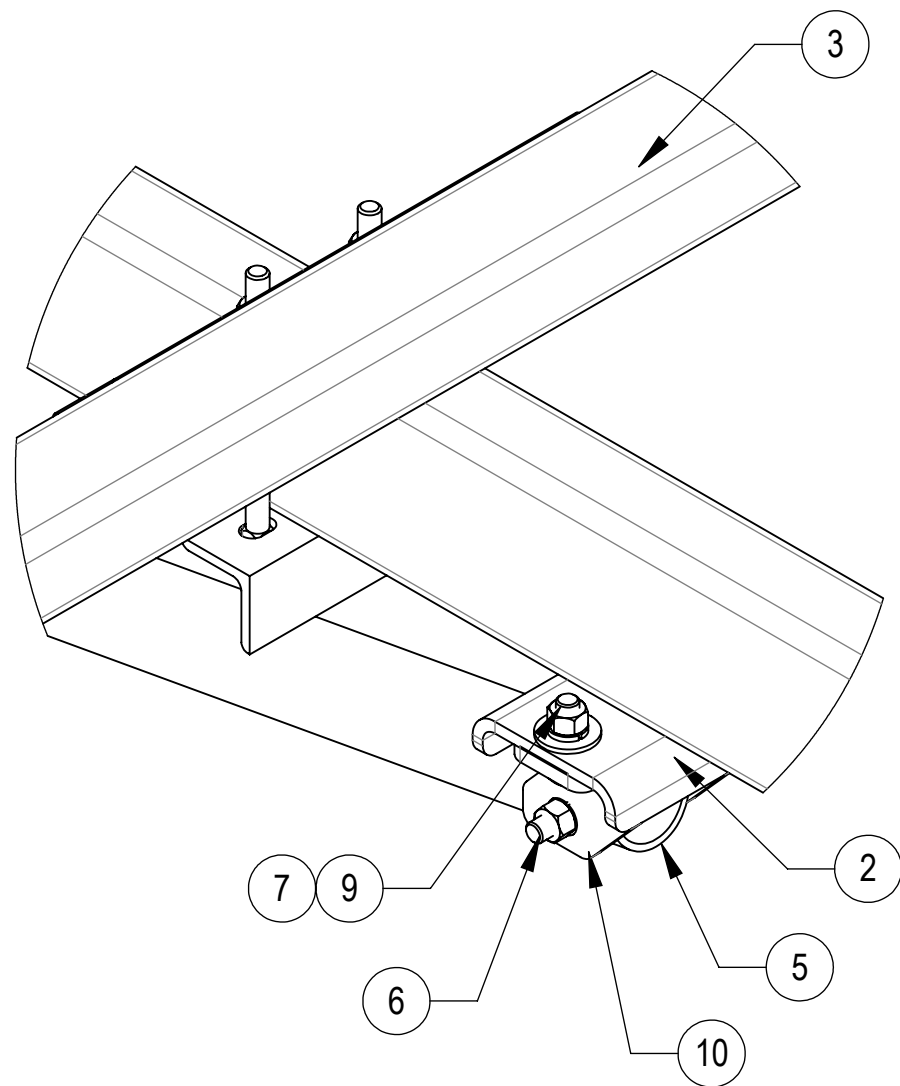

DETAIL D  
SCALE 1:5

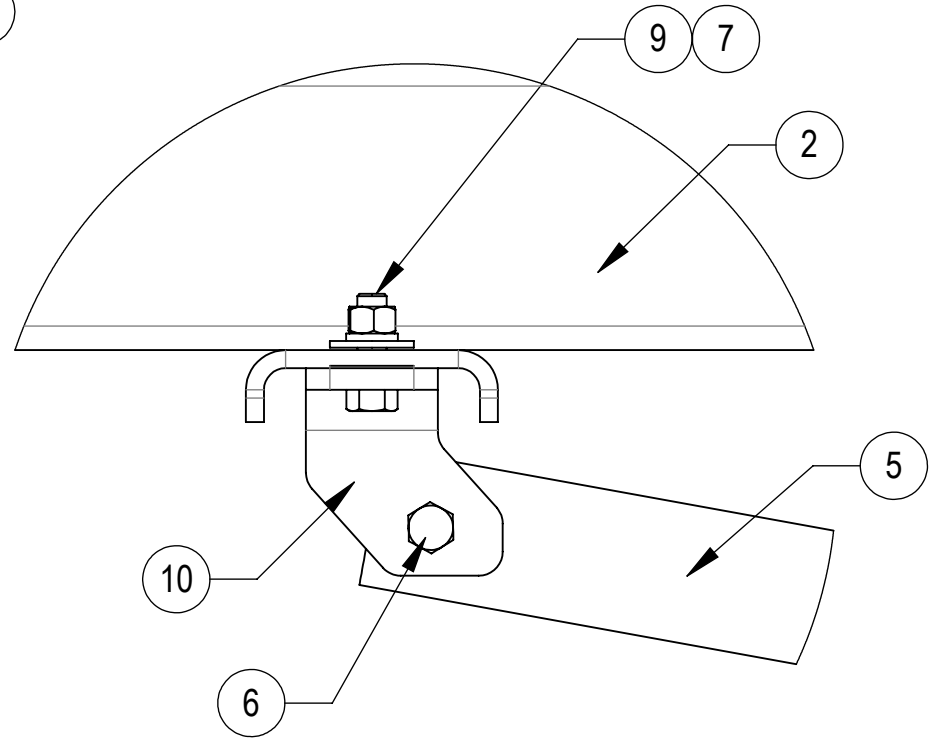

VIEW J-J  
SCALE 1:4  
ROTATED CROP VIEW

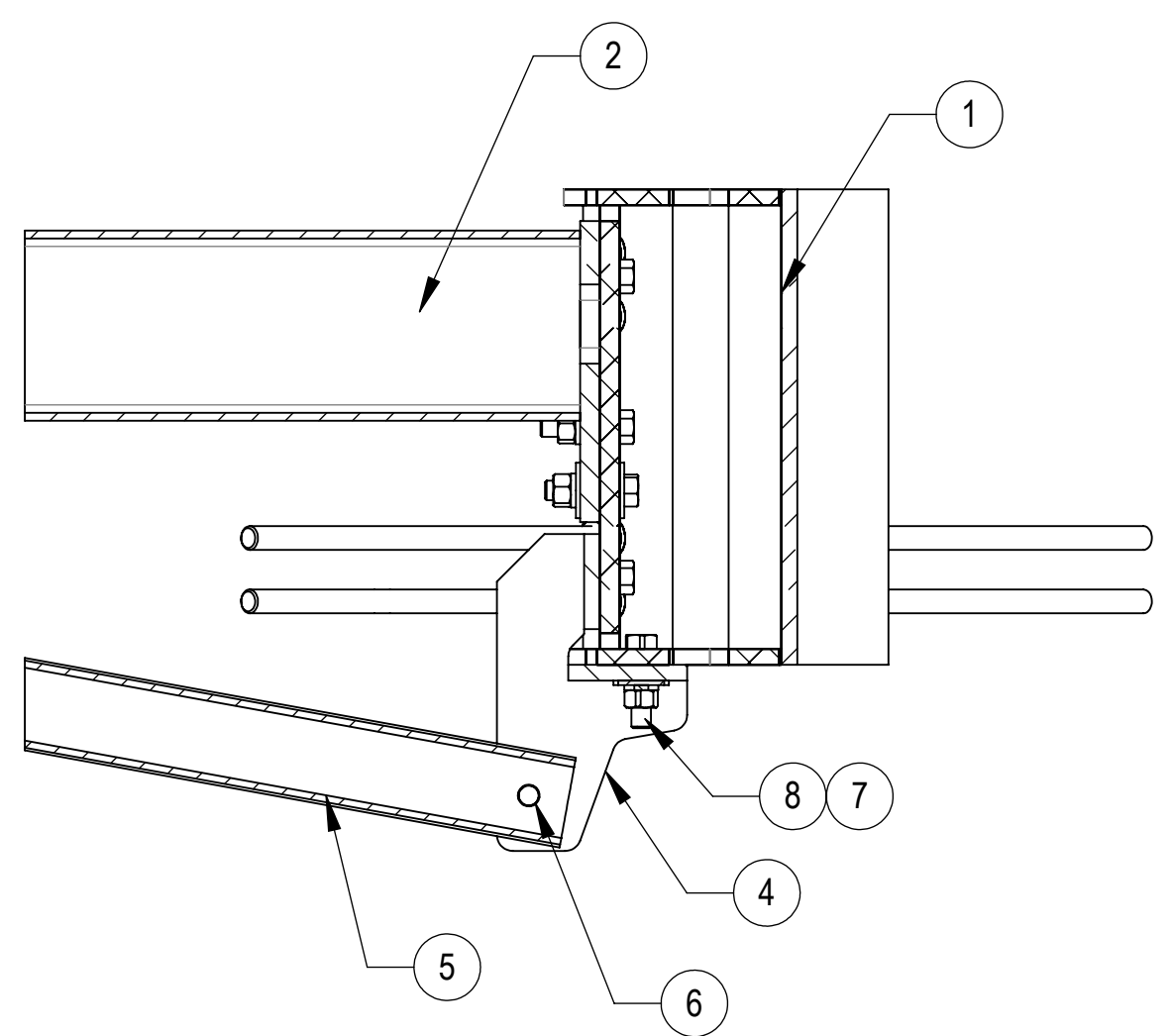
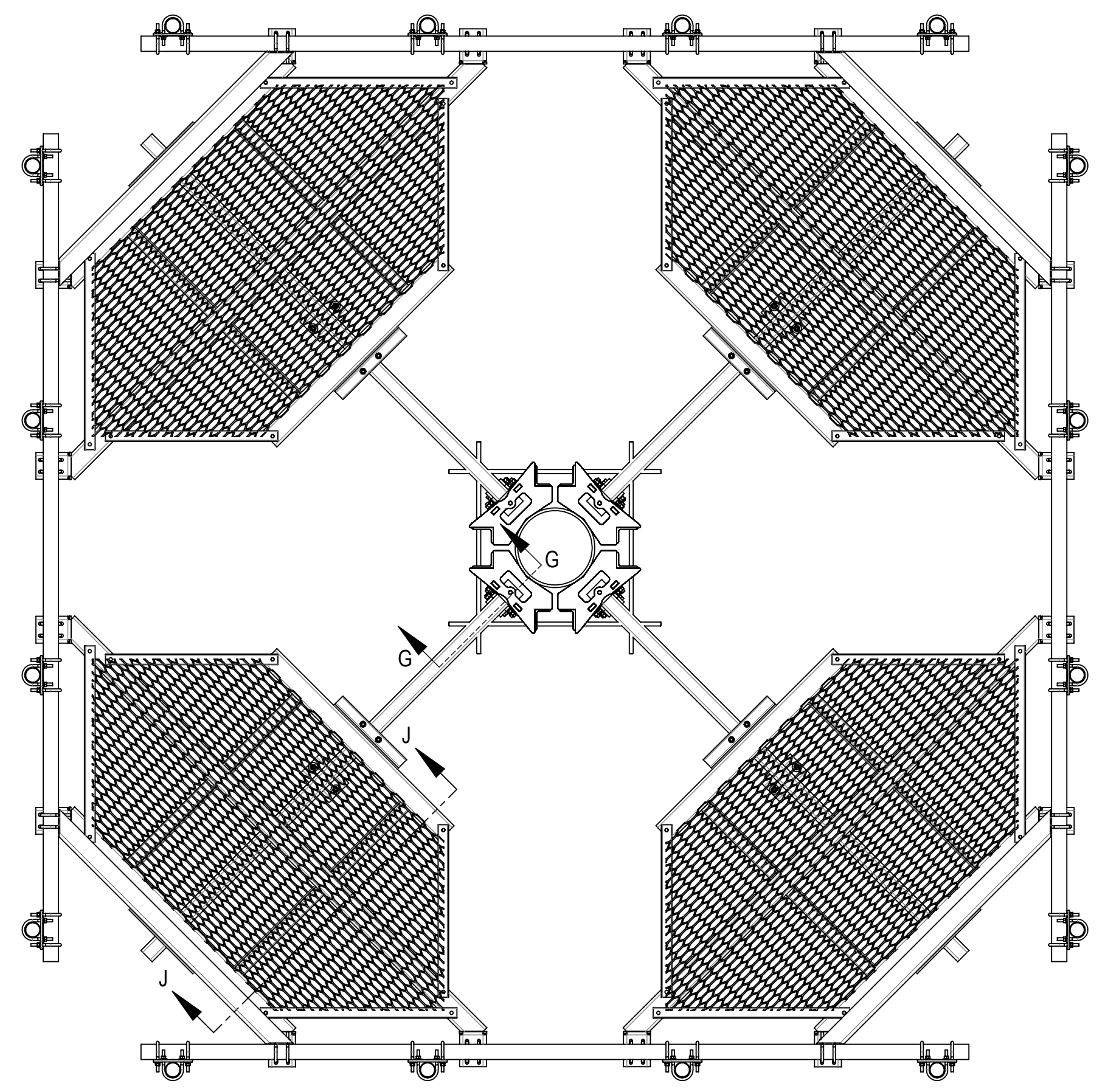

SECTION G-G  
SCALE 1:6  
ROTATED VIEW

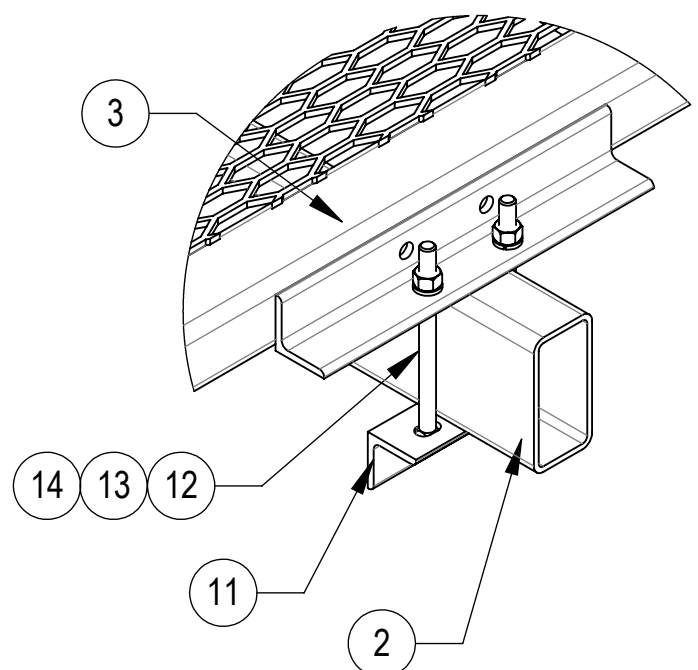

DETAIL C  
SCALE 1:7

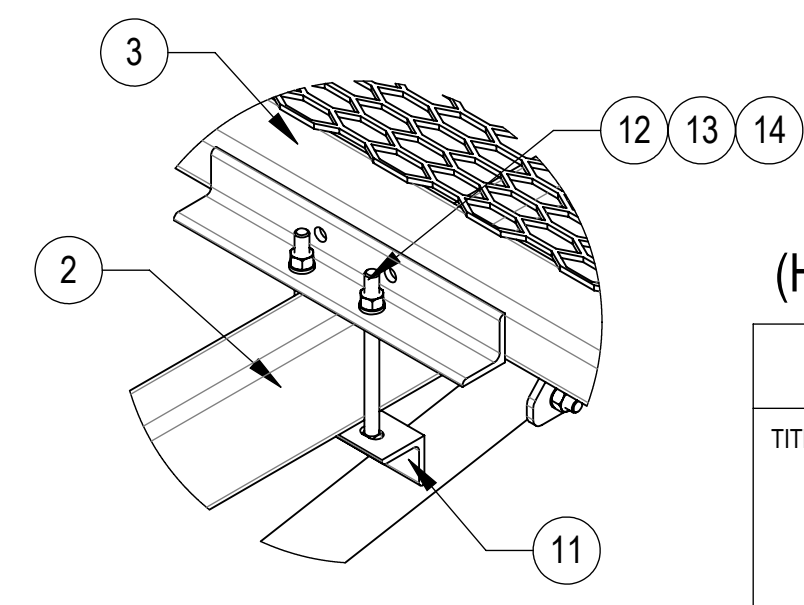

DETAIL E  
SCALE 1:8

(HIDDEN SOME PARTS FOR CLARITY)

COMMSCOPE, INC. OF NORTH CAROLINA			
TITLE			
SIZE <b>C</b>	SCALE <b>1:23</b>	DOCUMENT NO.	
DRAWING		SHEET	
VERSION	STATUS	REVISION	5 OF 9

ANTENNA SPACING SHOWN

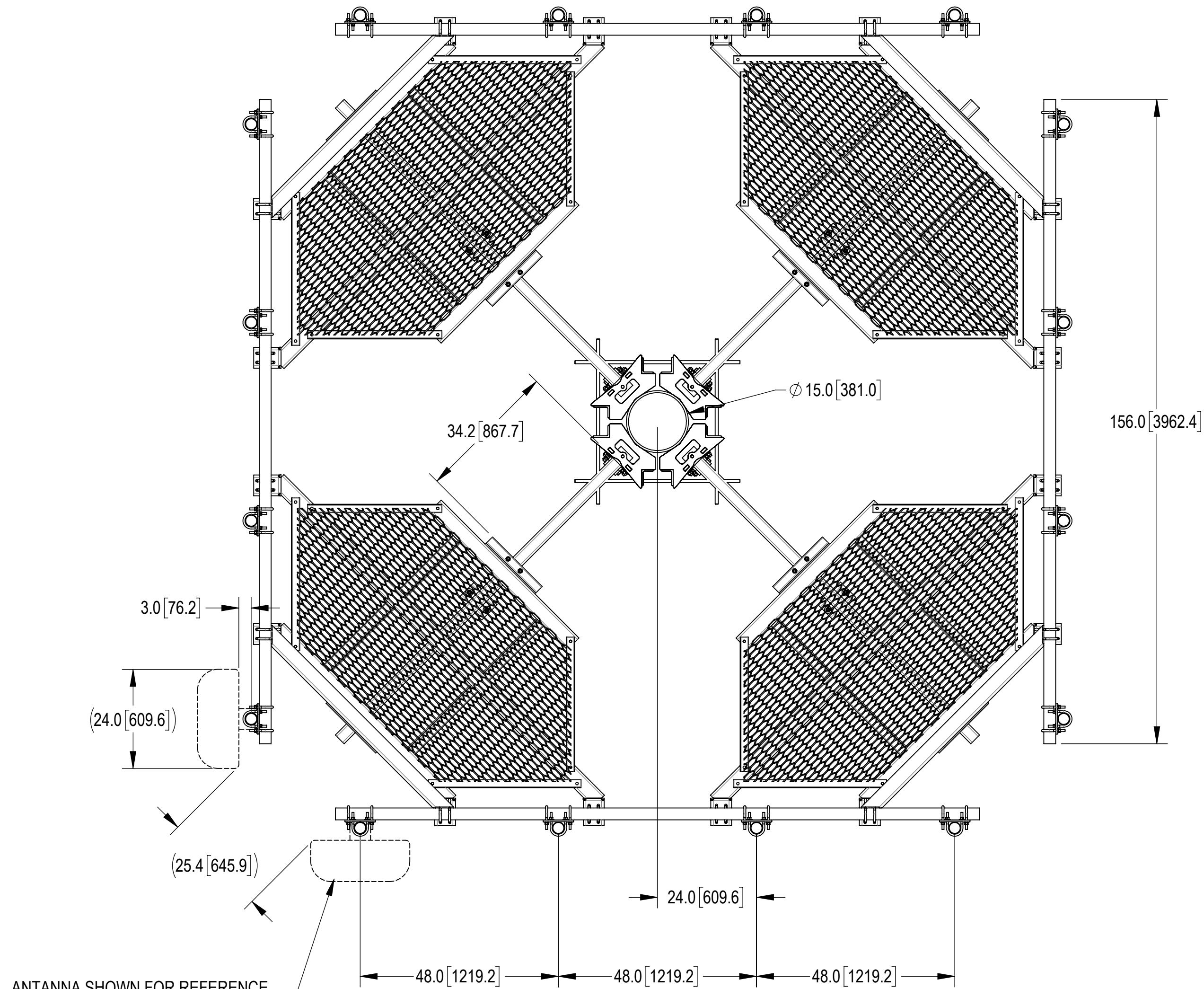

ANTENNA SHOWN FOR REFERENCE  
(NOT INCLUDED IN THIS KIT)

15" MONOPOLE

COMMSCOPE, INC. OF NORTH CAROLINA				
TITLE				
SIZE	SCALE	DOCUMENT NO.		
C	1:23			
		DRAWING		SHEET
		VERSION	STATUS	REVISION
				6 OF 9

4

3

2

1

D

D

C

C

B

B

A

A

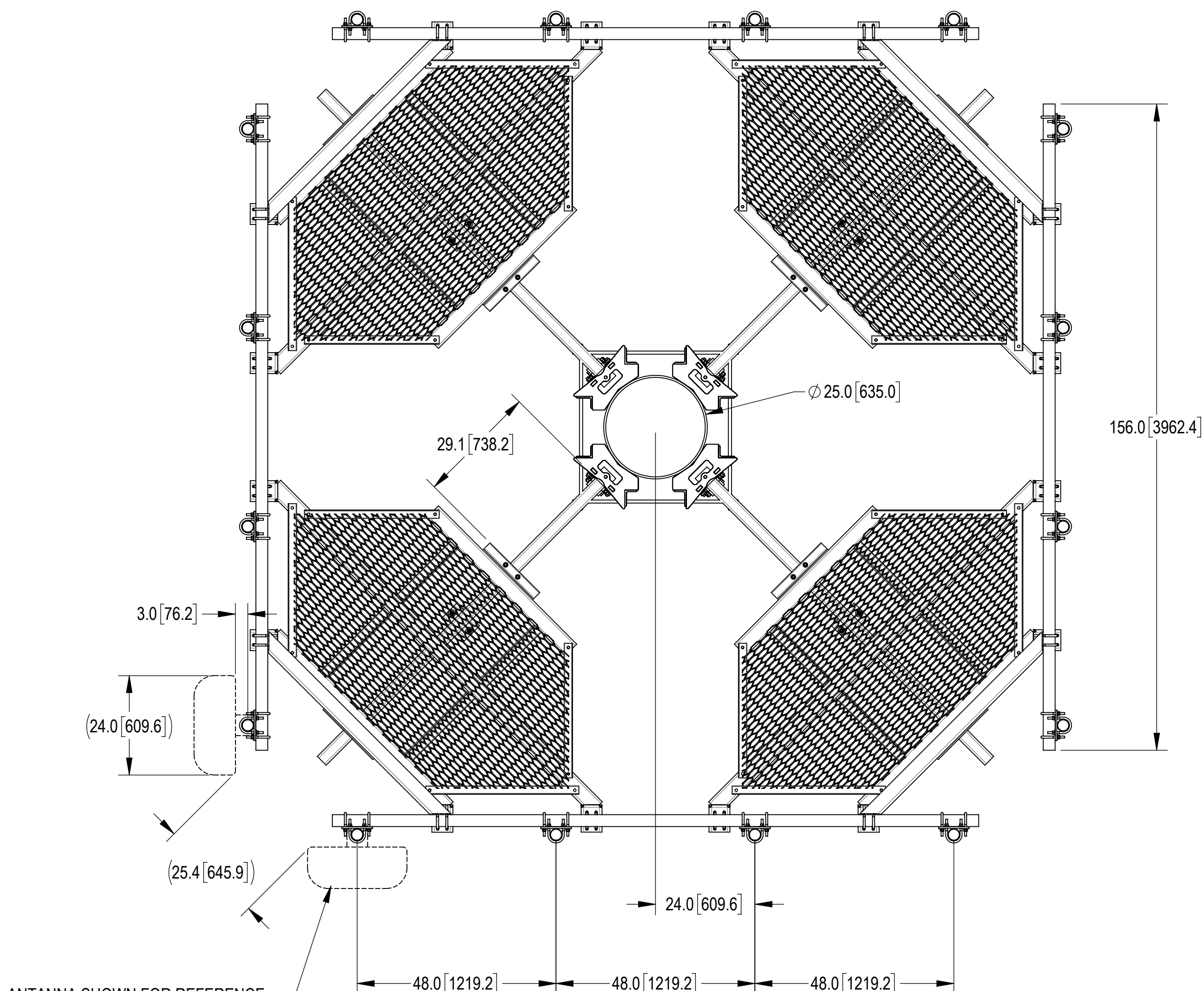

ANTENNA SHOWN FOR REFERENCE  
(NOT INCLUDED IN THIS KIT)

25" MONOPOLE

COMMSCOPE, INC. OF NORTH CAROLINA				
TITLE				
SIZE	SCALE	DOCUMENT NO.		
C	1:23			
		DRAWING		SHEET
		VERSION	STATUS	REVISION
				7 OF 9

4

3

2

1





4

3

2

1

D

D

C

C

B

B

A

A

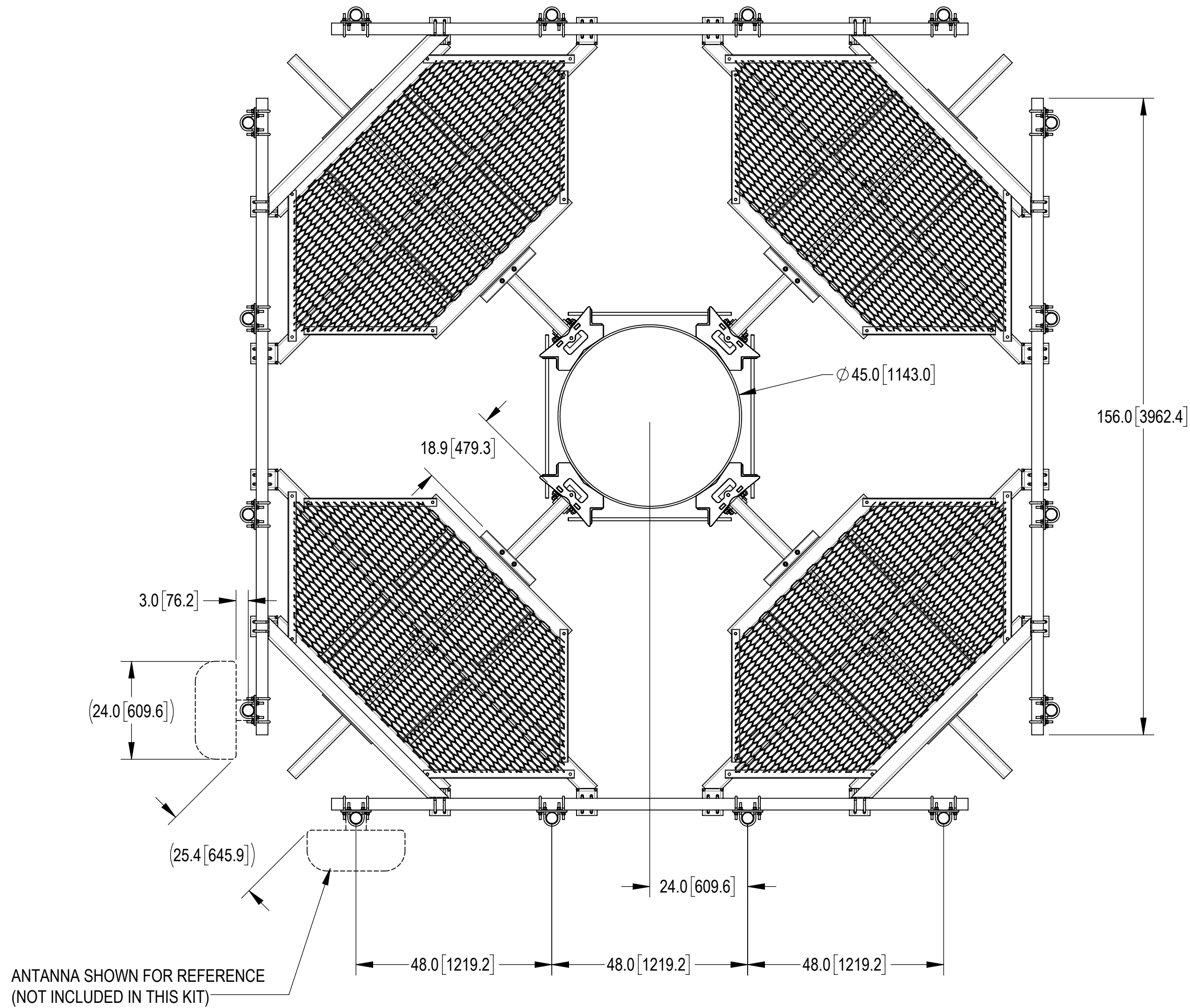



### 45" MONOPOLE

COMMSCOPE, INC. OF NORTH CAROLINA

TITLE

SIZE <b>C</b>	SCALE <b>1:23</b>	DOCUMENT NO.
------------------	----------------------	--------------

 	DRAWING			SHEET 9 OF 9
	VERSION	STATUS	REVISION	

4

3

2

1