

1.0 GENERAL NOTES

1.1 ALL METRIC DIMENSIONS ARE IN BRACKETS [X.X]

1.2 FOR PATENT INFO: <https://www.cs-pat.com>

2.0 DESIGN NOTES

2.1 ANY HAZARDS OR OBSTRUCTIONS TO THE CLIMBING FACILITY AND SAFETY CLIMB MUST BE IDENTIFIED PRIOR TO INSTALLING THE APPURTENANCE. ADDITIONAL PRODUCTS MAY BE REQUIRED TO MAINTAIN THE INTEGRITY OF THE SAFETY CLIMB. DURING INSTALLATION, TEMPORARY AND/OR PERMANENT PRECAUTIONARY MEASURES SHOULD BE TAKEN TO PRESERVE THE CLIMBING FACILITY AND/OR SAFETY CLIMB.

2.2 FITS MONOPOLES 15"-45" O.D.

2.3 ANTENNA PIPES SHOULD BE CENTERED AND EVENLY SPACED.

2.4 POSITION MOUNT OR ADJUST SAFETY CLIMB CABLE SO NOT TO HINDER OR DAMAGE OR OBSTRUCT THE SAFETY CLIMB. SAFETY CABLE ROUTING BRACKET MAY BE PURCHASED SEPARATELY.

3.0 MANUFACTURING/SPECIAL REQUIREMENTS

3.1 TIGHTEN ALL BOLTS SECURING FLAT PLATES BY THE TURN-OF-NUT METHOD. TIGHTEN ALL U-BOLTS USING TURN-OF-NUT METHOD WITH ATTENTION TO LEAVE EQUAL DISTANCE AND EQUAL FORCE ON EACH LEG OF THE U-BOLT. ALL FASTENERS SHOULD BE TIGHTENED PER AISC 6.5.2.

3.2 SUGGEST PRE-ASSEMBLE MINI KICKER BRACKET TO RING MOUNT ON THE GROUND.

4.0 TEST

5.0 PACKAGING

5.1 PACKAGING SHALL MEET COMMSCOPE REQUIREMENTS PER DOCUMENT IS-PL-3005

5.2 PRINTED DOCUMENT TO BE PLACED INSIDE POLYBAG AND THEN IN SHIPPING CONTAINER

5.3 EXTRA HARDWARE MAY BE SUPPLIED, BAGGED AND SHIPPED

REVISIONS			
REV.	DESCRIPTION	DATE	APPROVED
A	INITIAL RELEASE	JL1183 13MAY24	CB1094 40195402CMO

D

D

C

C

B

B

A

A

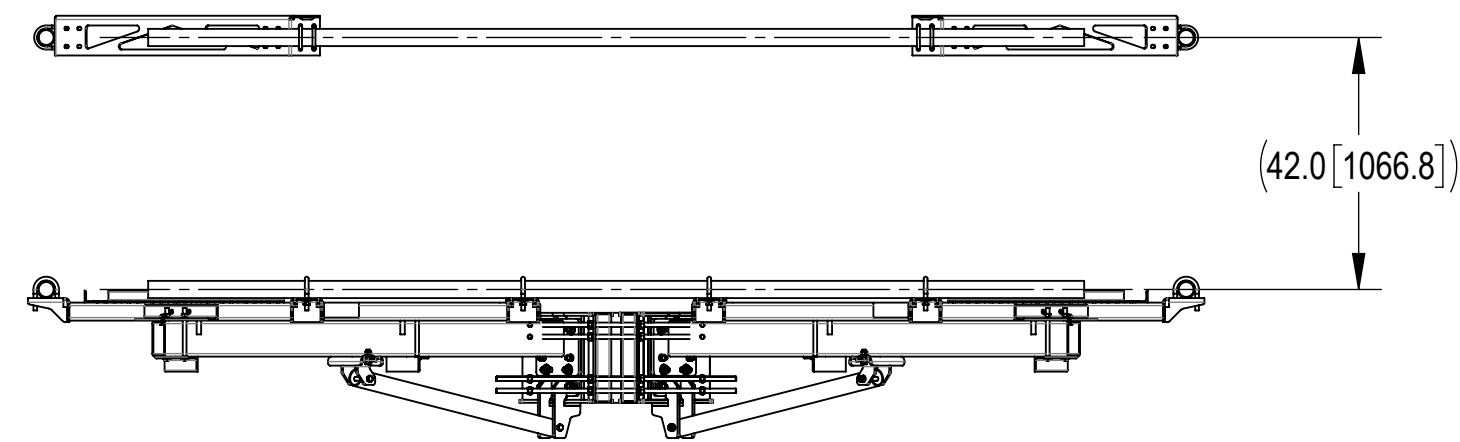
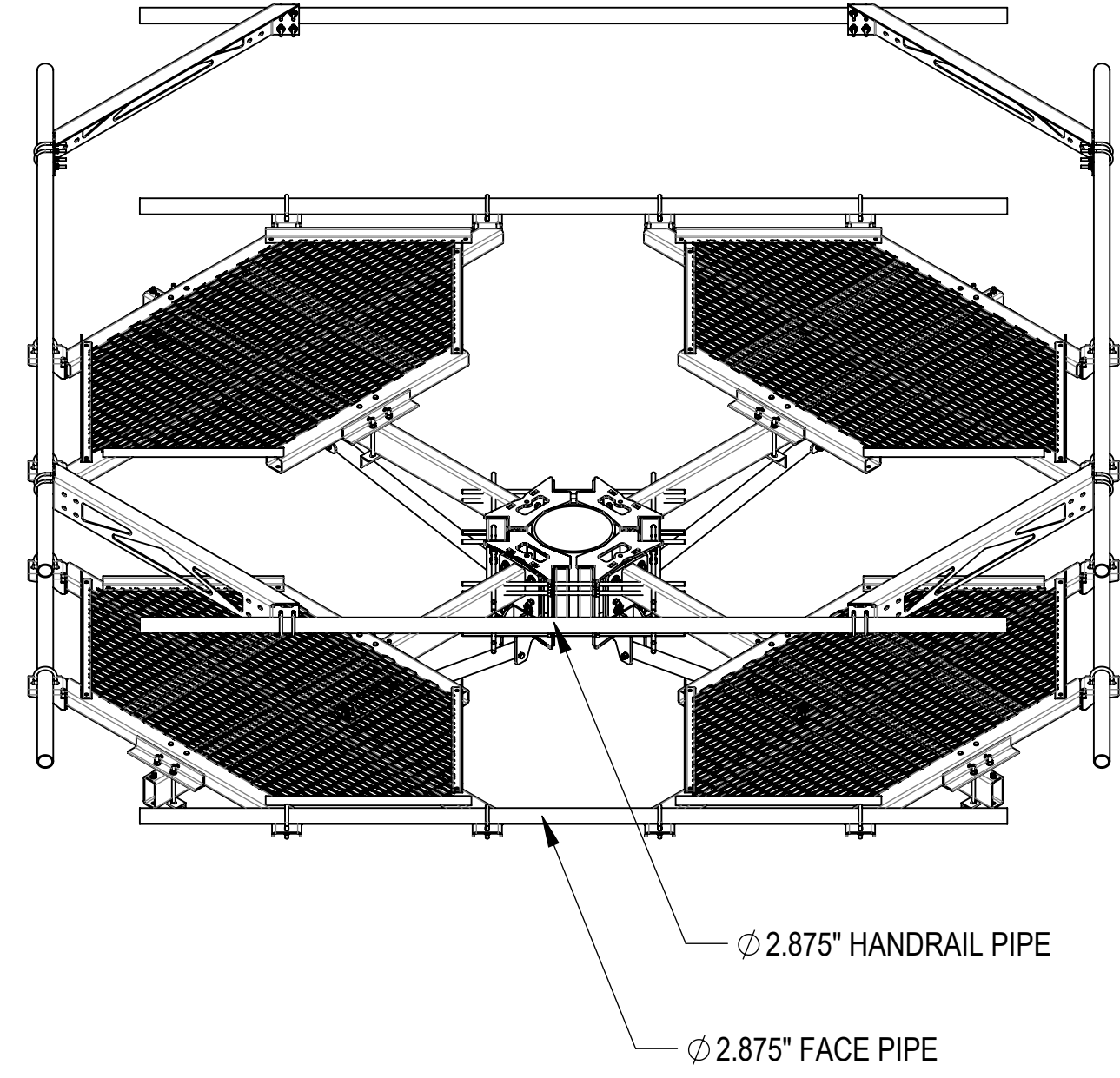
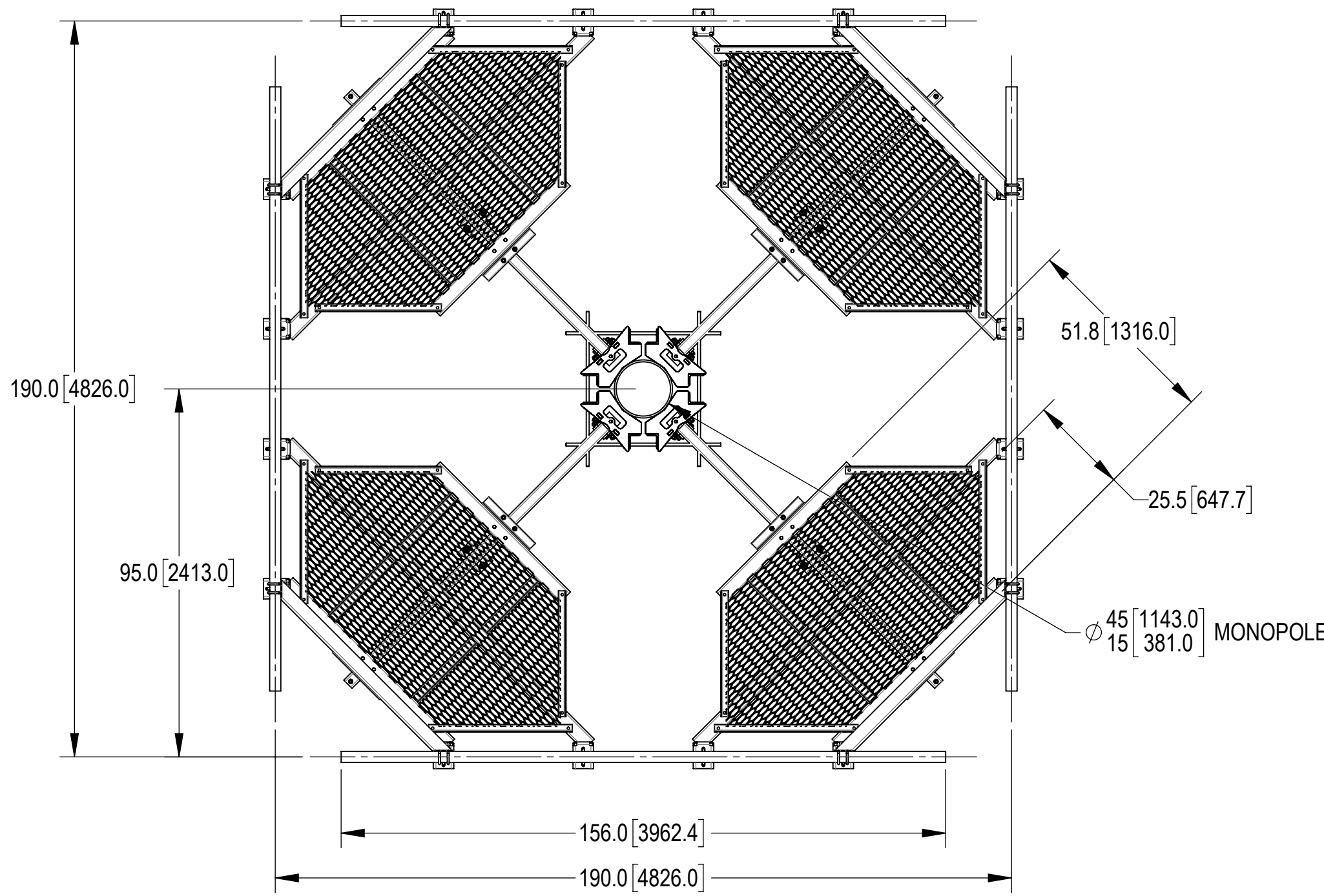

DENSITY	4327.92	lbs/in ³
MASS	4327.92	lbs
VOLUME	16719.79	in ³
SURFACE AREA	128093.36	in ²
HEIGHT	70.3"	
LENGTH	156.0"	
WIDTH	156.0"	

COMMSCOPE, INC. OF NORTH CAROLINA									
TOLERANCES					SAP MATERIAL MASTER				
1 PLACE .X[X] ± 0.2[6.3]		3 PLACE .XXX[X] ± 0.060[1.5]			MP-PP13M4-B				
2 PLACE .XX[X] ± 0.12[3.0]		ANGLES ± 2°							
FINISH					MATERIAL				
UNLESS OTHERWISE SPECIFIED DIMENSIONS ARE IN INCHES INTERPRET PER ANSI Y 14.5M-1994									
NAME		DATE		TITLE					
CE JL1183		13MAY24		MP,PLF,4S,13'FP,NOAP,W/HR					
RW JL1183		06/03/2024							
AD CB1094		06/05/2024							
RE JL1183		06/05/2024							
ECN 40195402CMO				SCALE		DOCUMENT NO.			
				1:32		MP-PP13M4-B			
SIZE		Auth Group		INSL		MODEL		DRAWING	
C		⊕		◁		VERSION		STATUS	
00		RE		A		00		RE	
A		A		A		A		A	
SHEET 1 OF 9									

4

3

2

1

PART NUMBERS, WEIGHTS, & EPA

TABLE 1: CONFIGURATIONS

PART NUMBER	DESCRIPTION	WEIGHT (LBS)	(EPA)A (FT^2)*	(EPA)A 1/2" ICE THICKNESS (FT^2)*	ANTENNA PIPES	INCLUDED PARTS					
						MC-RMHD-1245-4	MP-PP4M-SB01	RK-48-4NK	MPPP4-HK01	MT546156	HRK4-13-B
MP-PP13M4-B	MP,PLF,4S,13'FP,NOAP,W/HR	4327.9	60.93	75.62	-	1	1	1	1	4	1

* (EPA)A DOES NOT INCLUDE ANTENNA PIPES AND MOUNTING HARDWARE.

COMMSCOPE, INC. OF NORTH CAROLINA

TITLE
MP,PLF,4S,13'FP,NOAP,W/HR

SIZE C	SCALE 1:32	DOCUMENT NO. MP-PP13M4-B
------------------	----------------------	------------------------------------

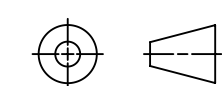

DRAWING			SHEET 2 OF 9
VERSION	STATUS	REVISION	
00	RE	A	

4

3

2

1

PLATFORM FOR INSTALLATION

ADJUST THE INSTALLATION DISTANCE ACCORDING TO THE DIAMETER OF THE MONOPOLE WHEN INSTALL PLATFORM MP-PP4-2000-00.
SEE TABLE 3 DETAIL FOR THE DISTANCE ADJUSTED.

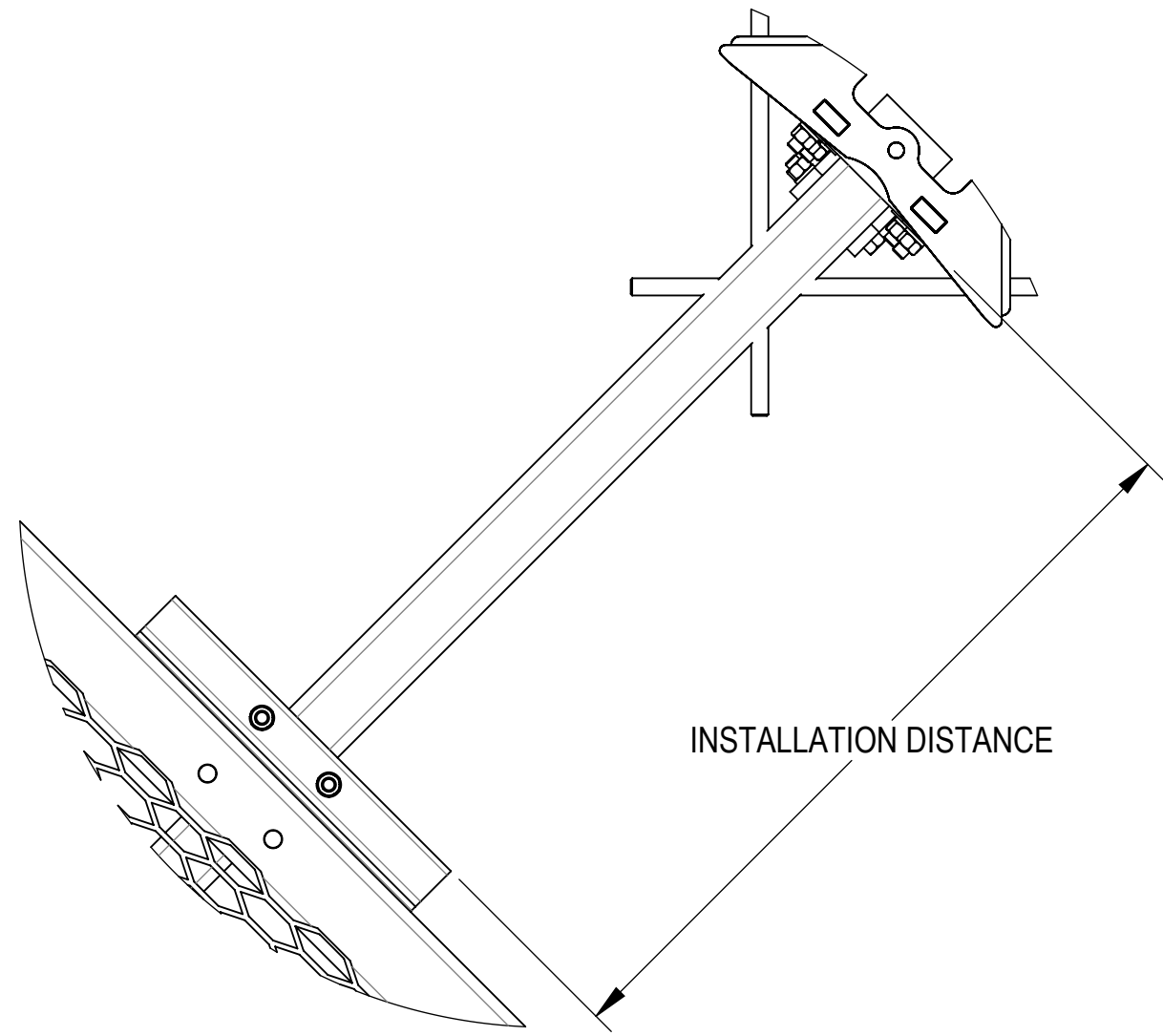

DETAIL A
SCALE 1 : 8

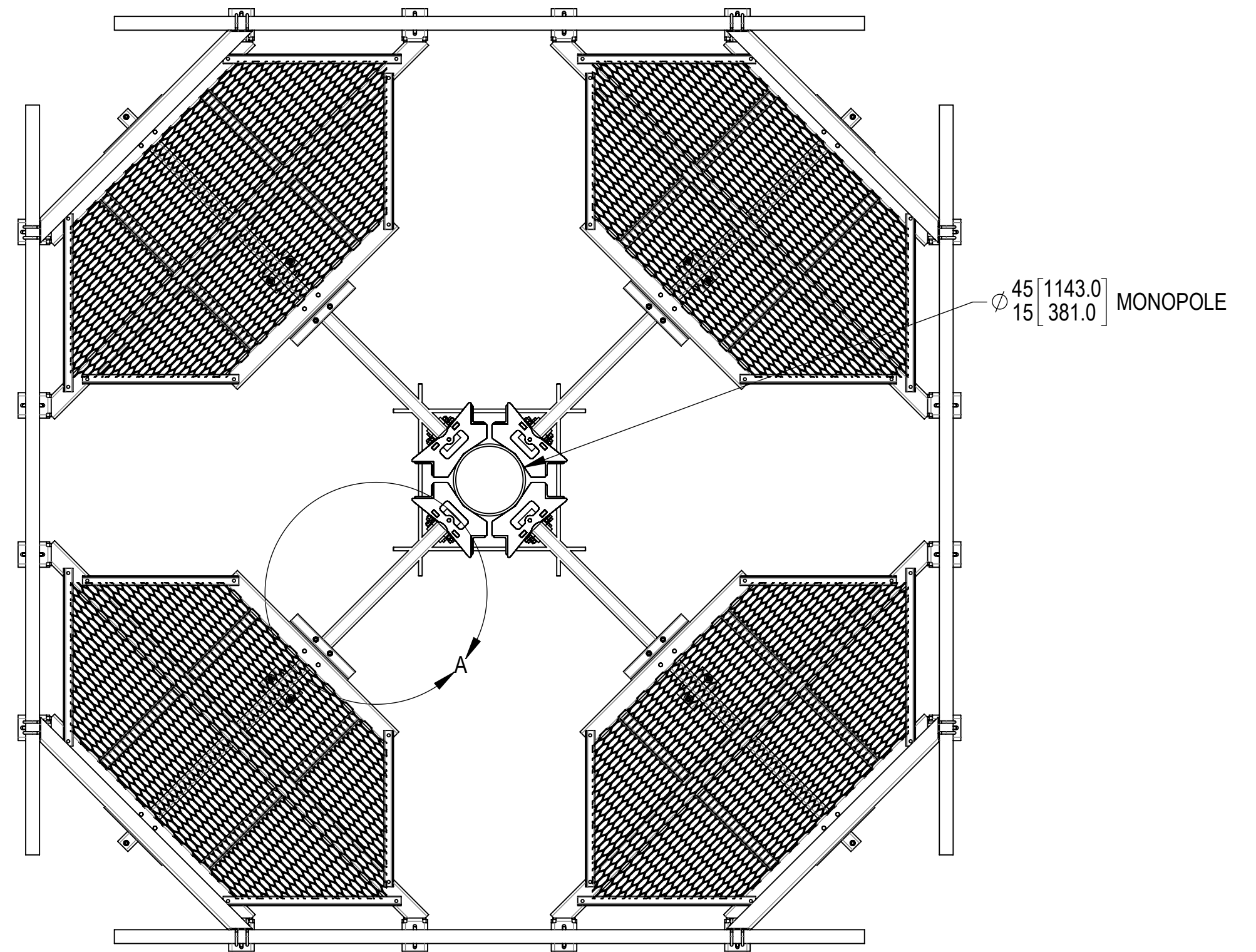
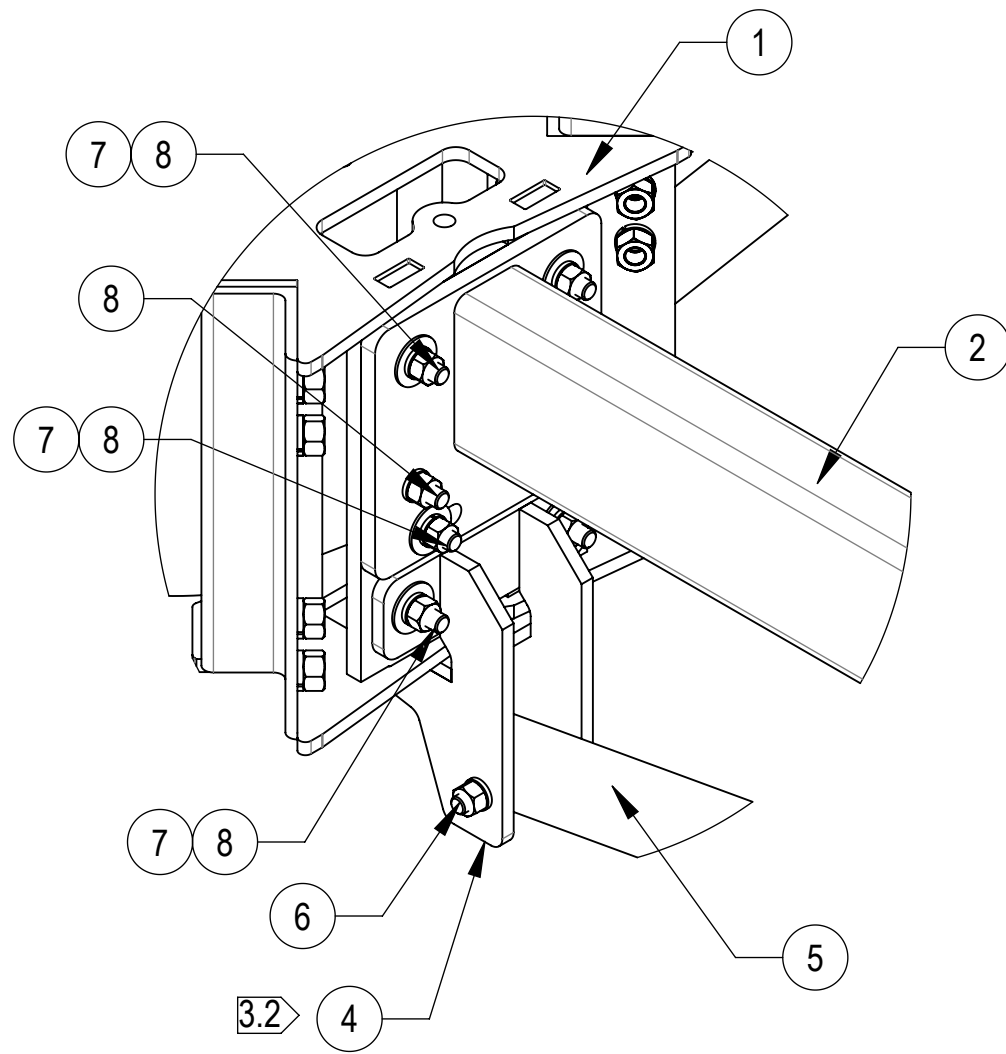

TABLE 3: PLATFORM INSTALLATION POSITION

DIAMETER OF MONOPOLE (INCH)	DISTANCE (INCH)	DIAMETER OF MONOPOLE (MM)	DISTANCE (MM)
15.0	34.05	381.0	864.87
17.5	32.78	444.5	832.49
20.0	31.50	508.0	800.10
22.5	30.23	571.5	767.72
25.0	28.95	635.0	735.33
27.5	27.68	698.5	702.95
30.0	26.40	762.0	670.56
32.5	25.13	825.5	638.18
35.0	23.85	889.0	605.79
37.5	22.58	952.5	573.41
40.0	21.30	1016.0	541.02
42.5	20.03	1079.5	508.64
45.0	18.75	1143.0	476.25

NOTE: FOR MONOPOLE DIAMETERS THAT ARE NOT IN THE TABLE, USE BELOW FORMULA TO GET THE VALUE OF THE ADJUSTMENT:
DISTANCE OF ADJUSTMENT = 41.70-0.51*D (INCH), WHERE D(INCH) IS THE DIAMETER OF MONOPOLE

COMMSCOPE, INC. OF NORTH CAROLINA			
TITLE MP,PLF,4S,13'FP,NOAP,W/HR			
SIZE C	SCALE 1:23	DOCUMENT NO. MP-PP13M4-B	
DRAWING			SHEET
VERSION 00	STATUS RE	REVISION A	3 OF 9



DETAIL B
SCALE 1 : 6

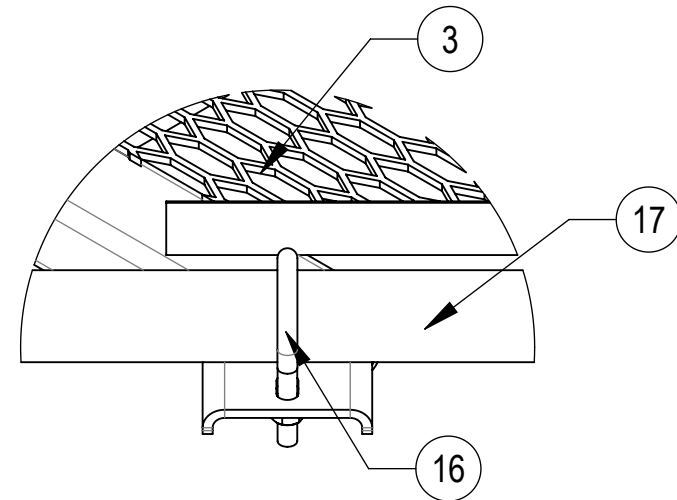

DETAIL F
SCALE 1 : 6

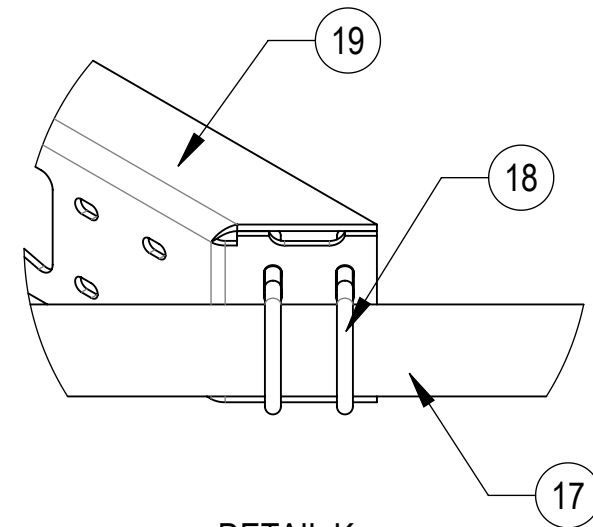

DETAIL K
SCALE 1 : 6

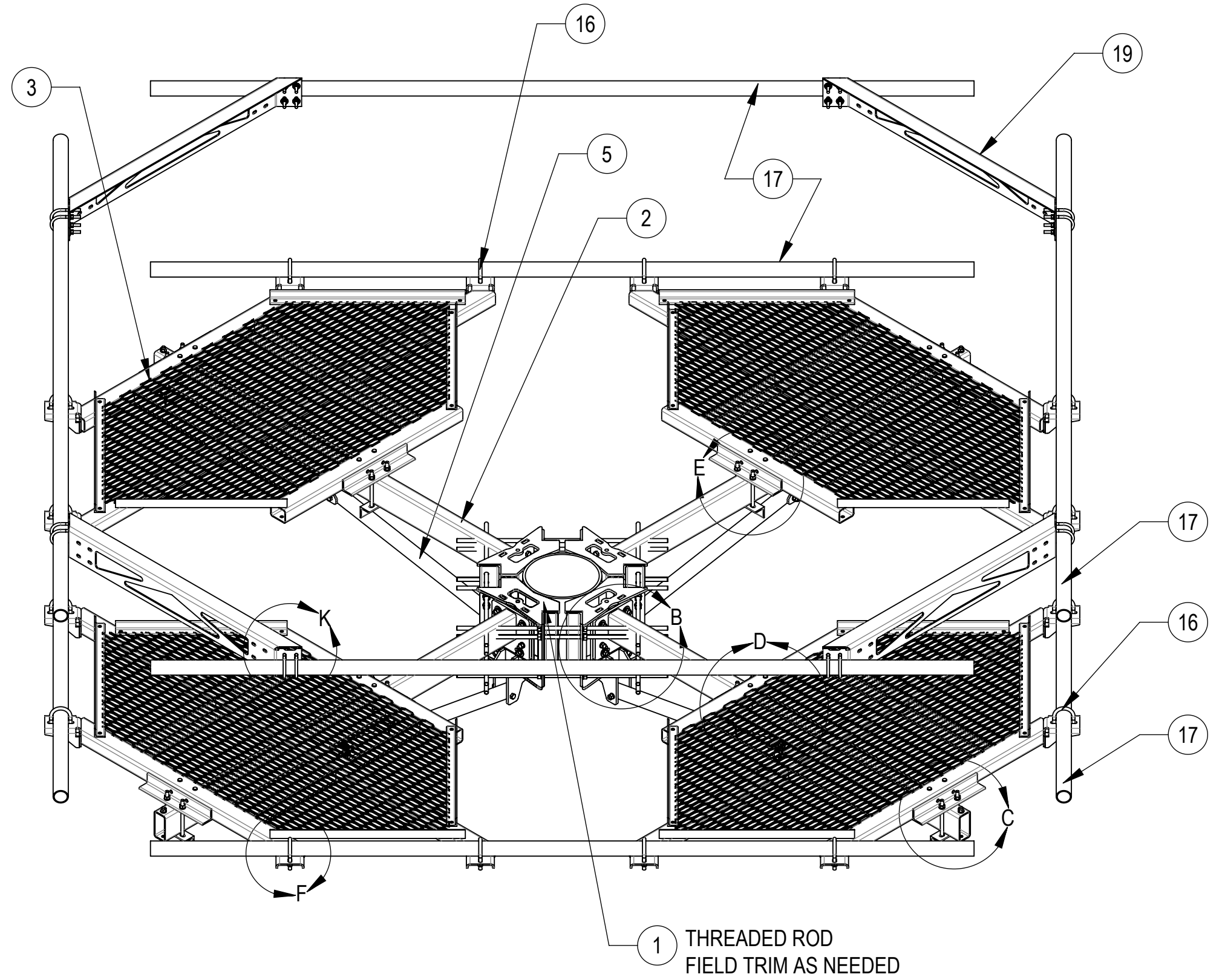

1 THREADED ROD
FIELD TRIM AS NEEDED

COMPONENT PART NUMBERS PROVIDED FOR ASSEMBLY PURPOSES;
INDIVIDUAL COMPONENTS MAY BE SHIPPED AS PARTS WITHIN AN INCLUDED KIT.

ITEM NO.	PART NUMBER	DESCRIPTION	QTY.	WEIGHT
1	MC-RMHD-1545-4	4 SECTOR RING MOUNT, 15"-45" POLE	4	386.57LBS
2	MP-PP4-1000-00	WELDMENT, MONO PLATF SPINDLE	4	128.53 LBS
3	MP-PP4-2000-00	WELDMENT, CO-LOCATION PLATFORM DECK	4	315.08 LBS
4	MC-AS-6100-00	WELDMENT, MINI KICKER BRACKET	4	14.77 LBS
5	RK48-00	MINI KICKER ARM SUPPORT TUBE 48"	4	22.96 LBS
6	GB-0550A	5/8" X 5" GALV BOLT KIT (A325)	8	0.52 LBS
7	GWF-05	5/8" GALV FLAT WASHER, 1.7OD	44	0.06 LBS
8	GB-0524A	5/8" X 2-1/2" GALV HEX BOLT (A325)	36	0.31 LBS
9	GB-0520A	5/8" X 2" GALV BOLT KIT (A325)	8	0.26 LBS
10	MC-AS-6400-00	WELDMENT, MINI KICKER CLIP	4	5.97 LBS
11	MC-AS-1200-00	CLAMP PLATE, CO-LOCATION PLATFORM	8	2.97 LBS
12	9615-14	BOLT, CARRIAGE, 5/8-11, 8.5, STL GALV	16	0.82 LBS
13	GWL-05	5/8" GALV LOCK WASHER	16	0.03 LBS
14	GN-05	5/8" GALV HEX NUT	16	0.08 LBS
15	GB-05125	5/8" X 1-1/4" GALV BOLT KIT	4	0.20 LBS
16	GUB-53050	5/8" X 3" X 5" GALV U-BOLT KIT	16	1.09 LBS
17	MT546156	2.875" O.D. X 156" PIPE	8	75.58 LBS
18	GUB-4352	1/2" X 3" X 5-1/4" GALV U-BOLT	16	0.71 LBS
19	MP-PP4-6000-00	CONNER WELDMEMT, HANDRAIL	4	34.20 LBS

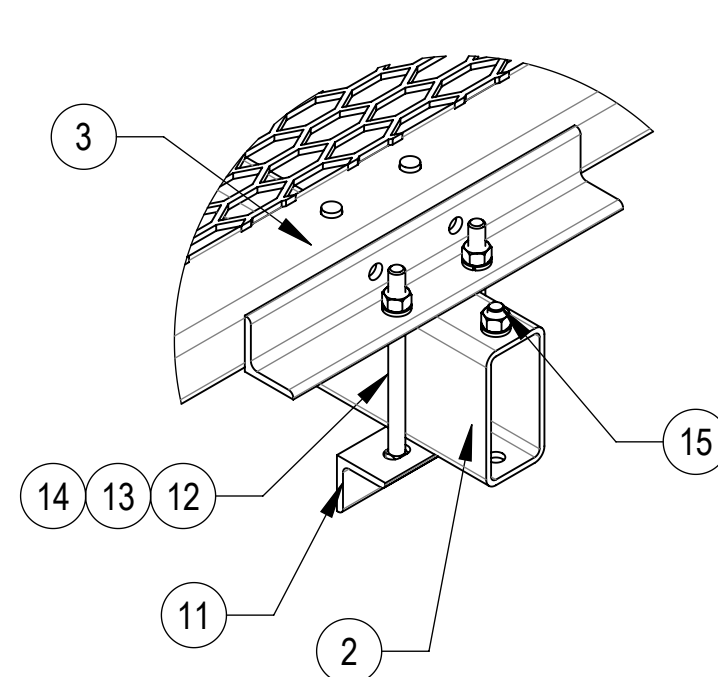

DETAIL C
SCALE 1 : 7

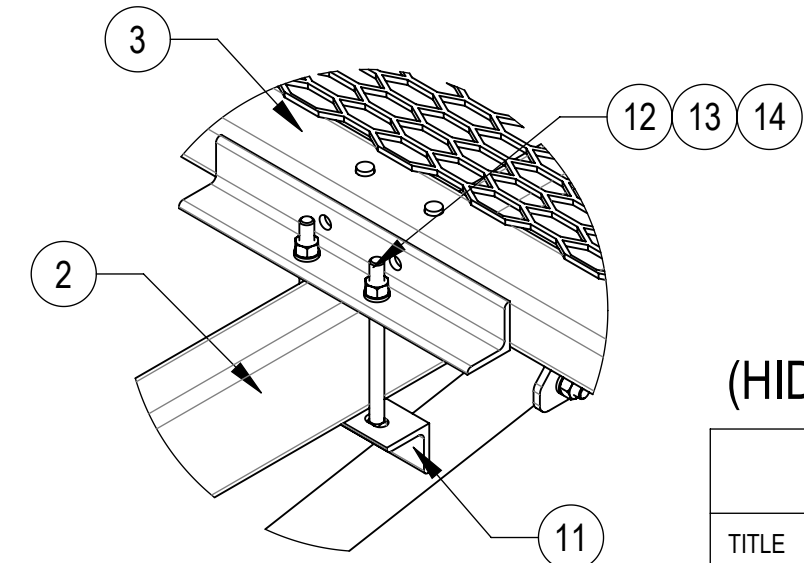

DETAIL E
SCALE 1 : 8

(HIDDEN SOME PARTS FOR CLARITY)

COMMSCOPE, INC. OF NORTH CAROLINA				
TITLE MP, PLF, 4S, 13'FP, NOAP, W/HR				
SIZE C	SCALE 1:23	DOCUMENT NO. MP-PP13M4-B		
		DRAWING		SHEET
		VERSION	STATUS	REVISION
		00	RE	A
				SHEET 4 OF 9

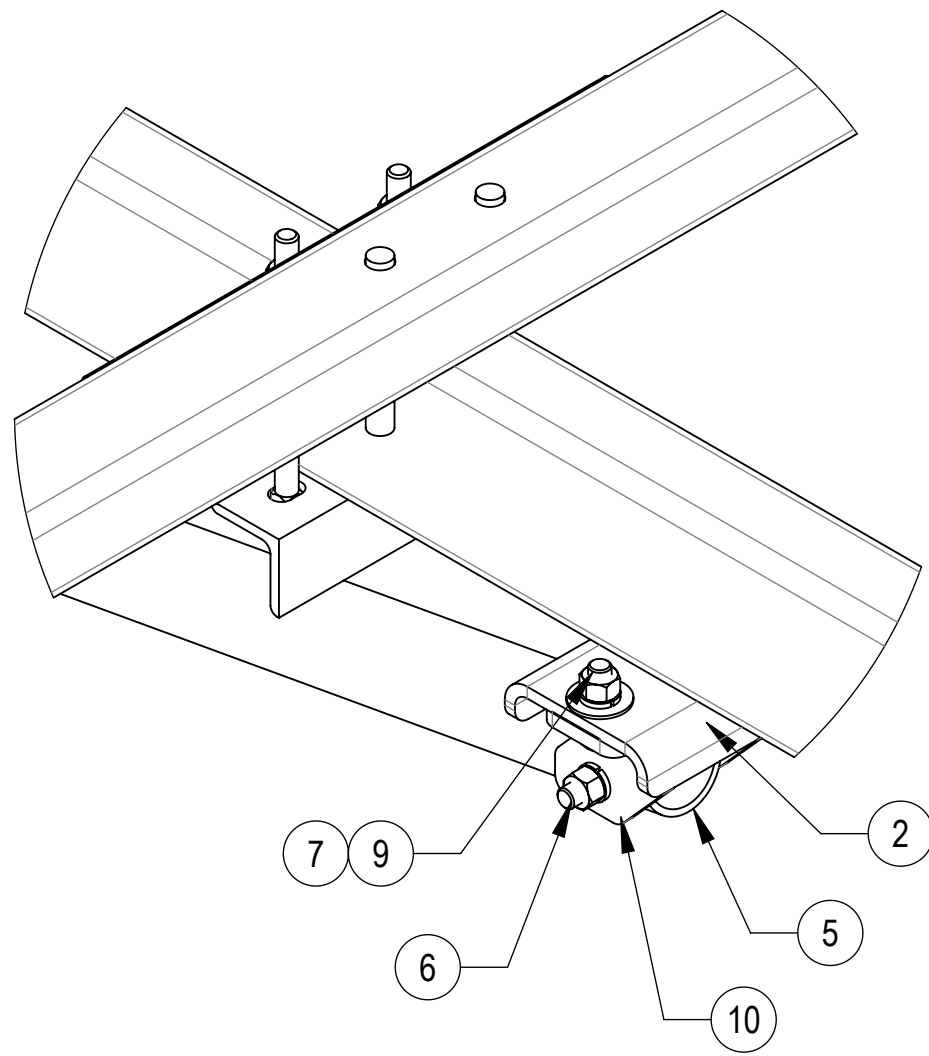

DETAIL D
SCALE 1:5

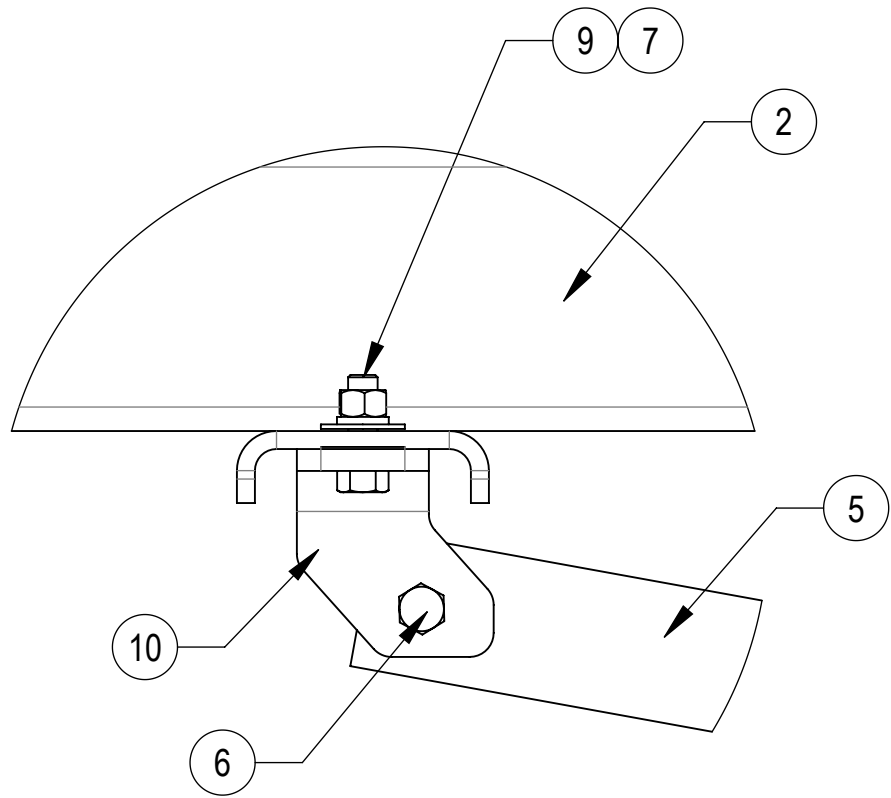

VIEW J-J
SCALE 1:4
ROTATED CROP VIEW

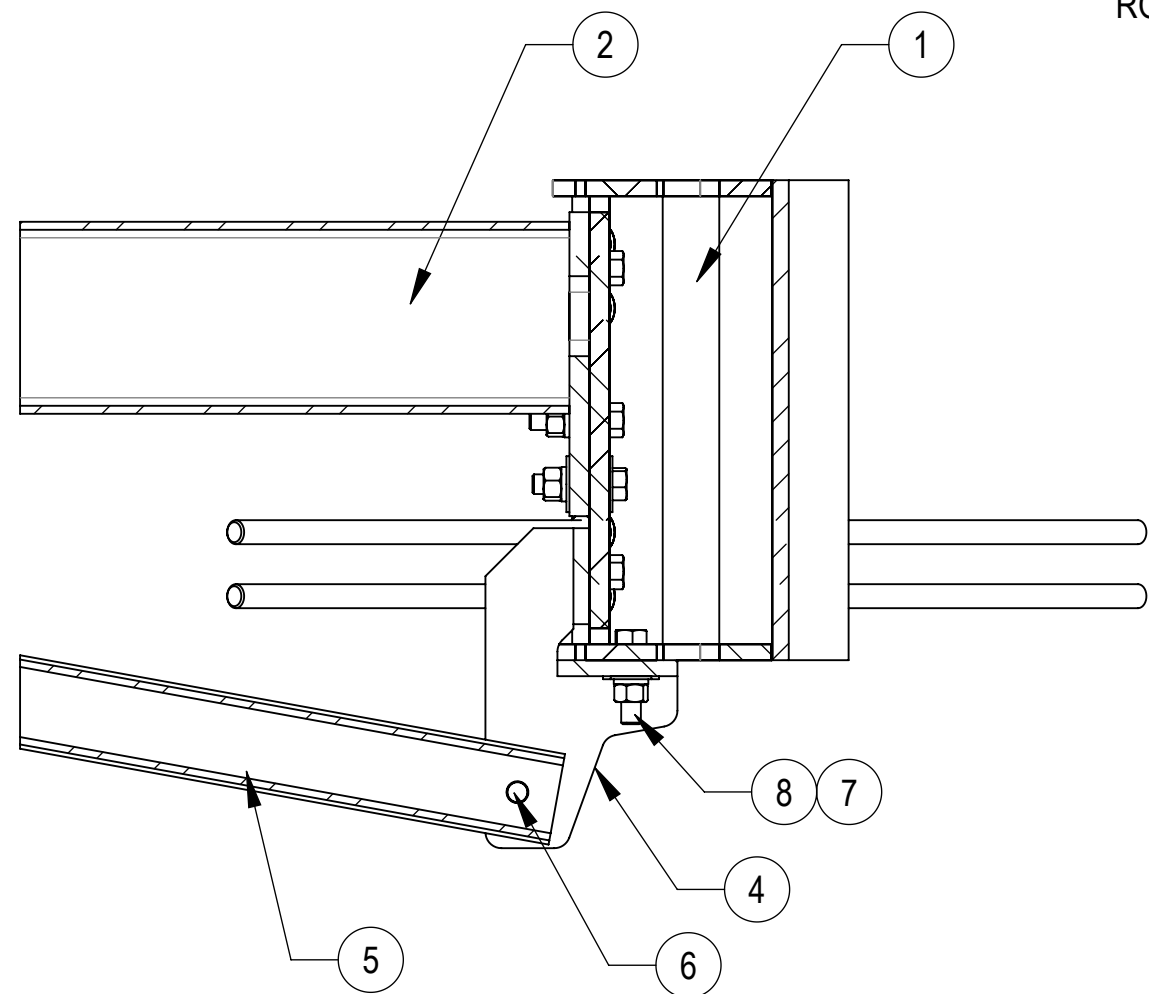

SECTION G-G
SCALE 1:6
ROTATED VIEW

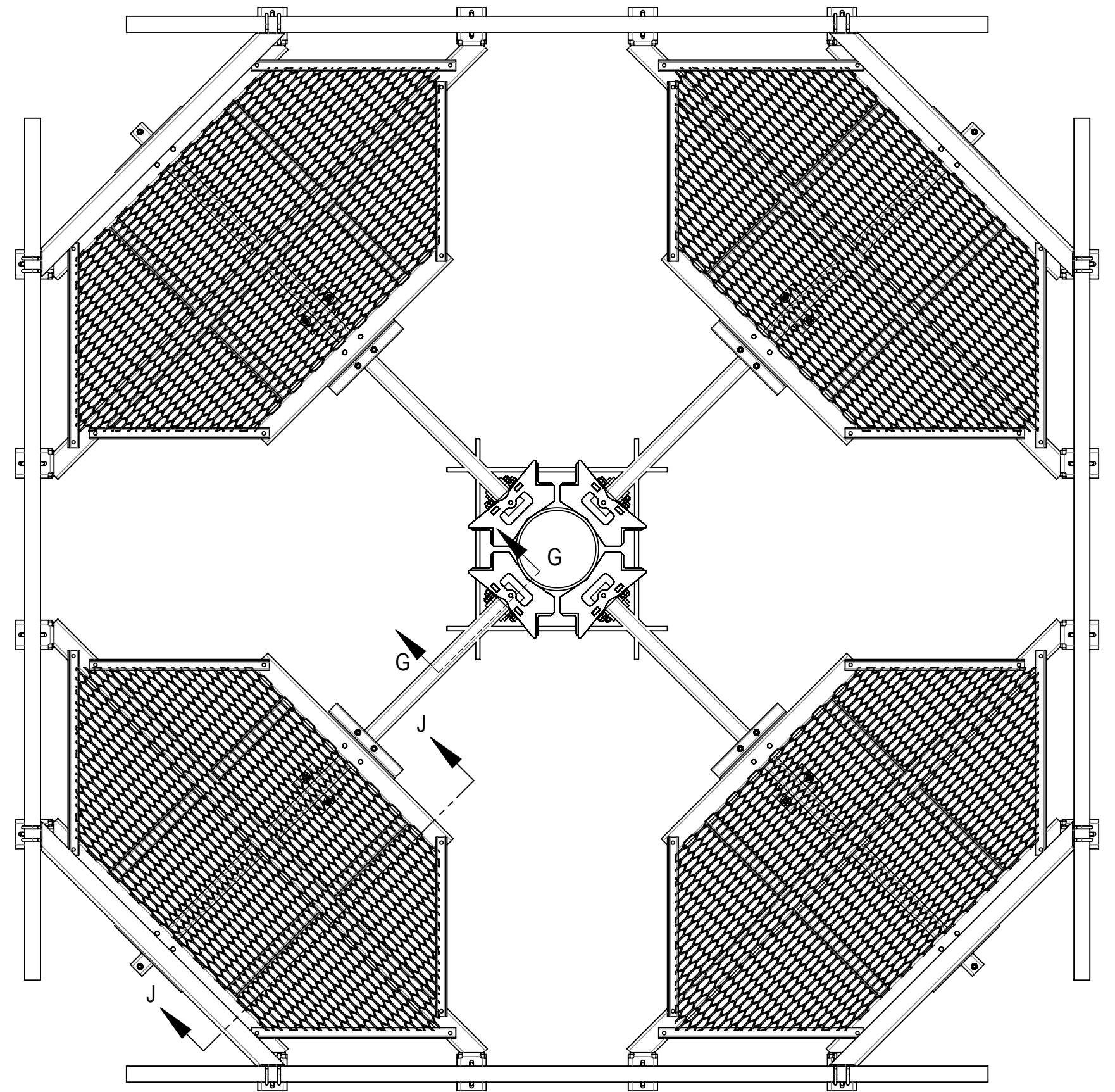



(HIDDEN SOME PARTS FOR CLARITY)

COMMSCOPE, INC. OF NORTH CAROLINA				
TITLE MP,PLF,4S,13'FP,NOAP,W/HR				
SIZE C	SCALE 1:23	DOCUMENT NO. MP-PP13M4-B		
		DRAWING		SHEET
		VERSION 00	STATUS RE	REVISION A
				5 OF 9

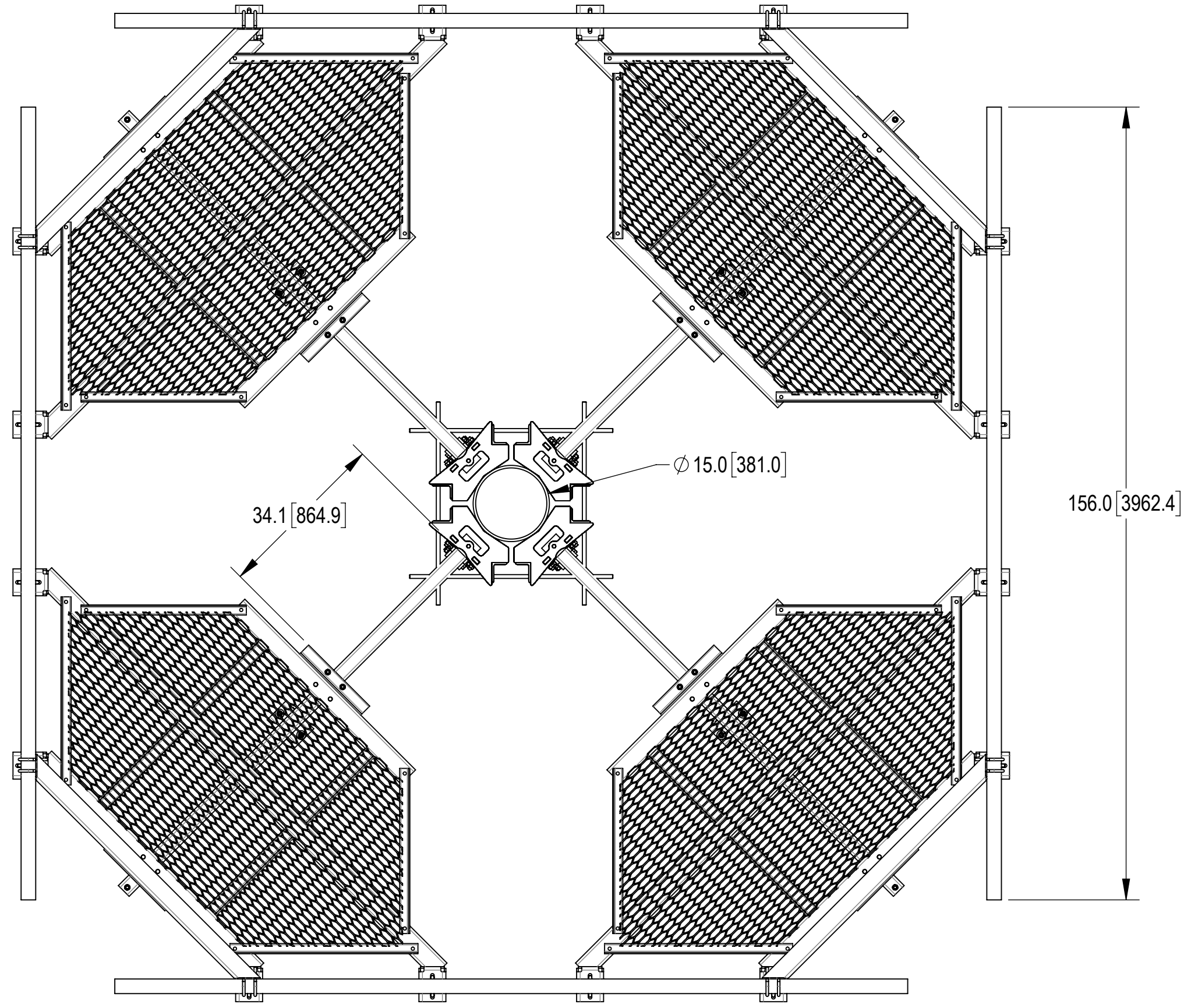
DIFFERENT MONOPOLE DIAMETER LAYOUT SHOWN



15" MONOPOLE

COMMSCOPE, INC. OF NORTH CAROLINA				
TITLE MP,PLF,4S,13'FP,NOAP,W/HR				
SIZE C	SCALE 1:23	DOCUMENT NO. MP-PP13M4-B		
 		DRAWING		SHEET 6 OF 9
		VERSION 00	STATUS RE	

4

3

2

1

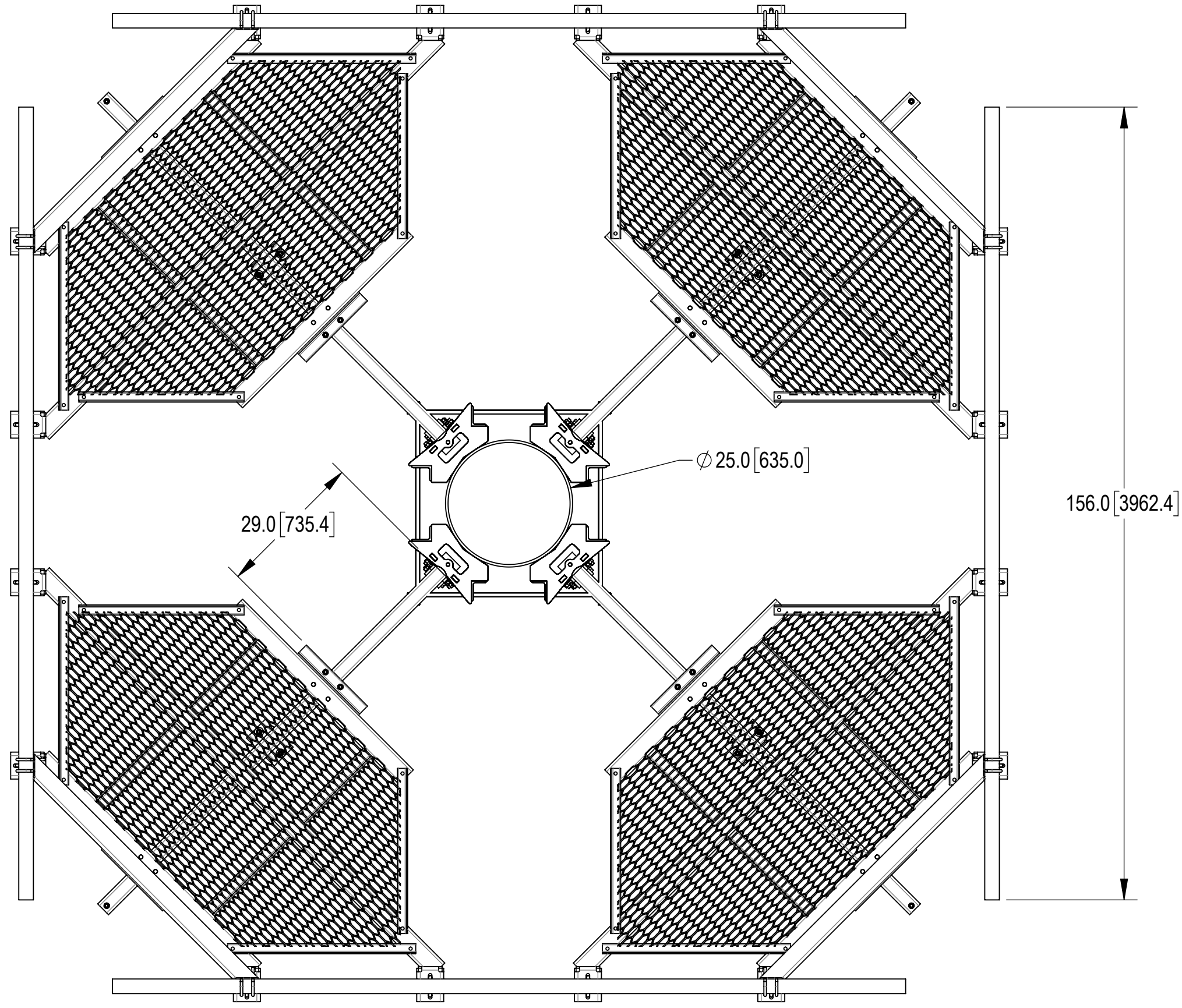

25" MONOPOLE

COMMSCOPE, INC. OF NORTH CAROLINA				
TITLE MP,PLF,4S,13'FP,NOAP,W/HR				
SIZE C	SCALE 1:23	DOCUMENT NO. MP-PP13M4-B		
		DRAWING		SHEET
		VERSION	STATUS	REVISION
		00	RE	A
				7 OF 9

4

3

2

1

4

3

2

1

D

D

C

C

B

B

A

A

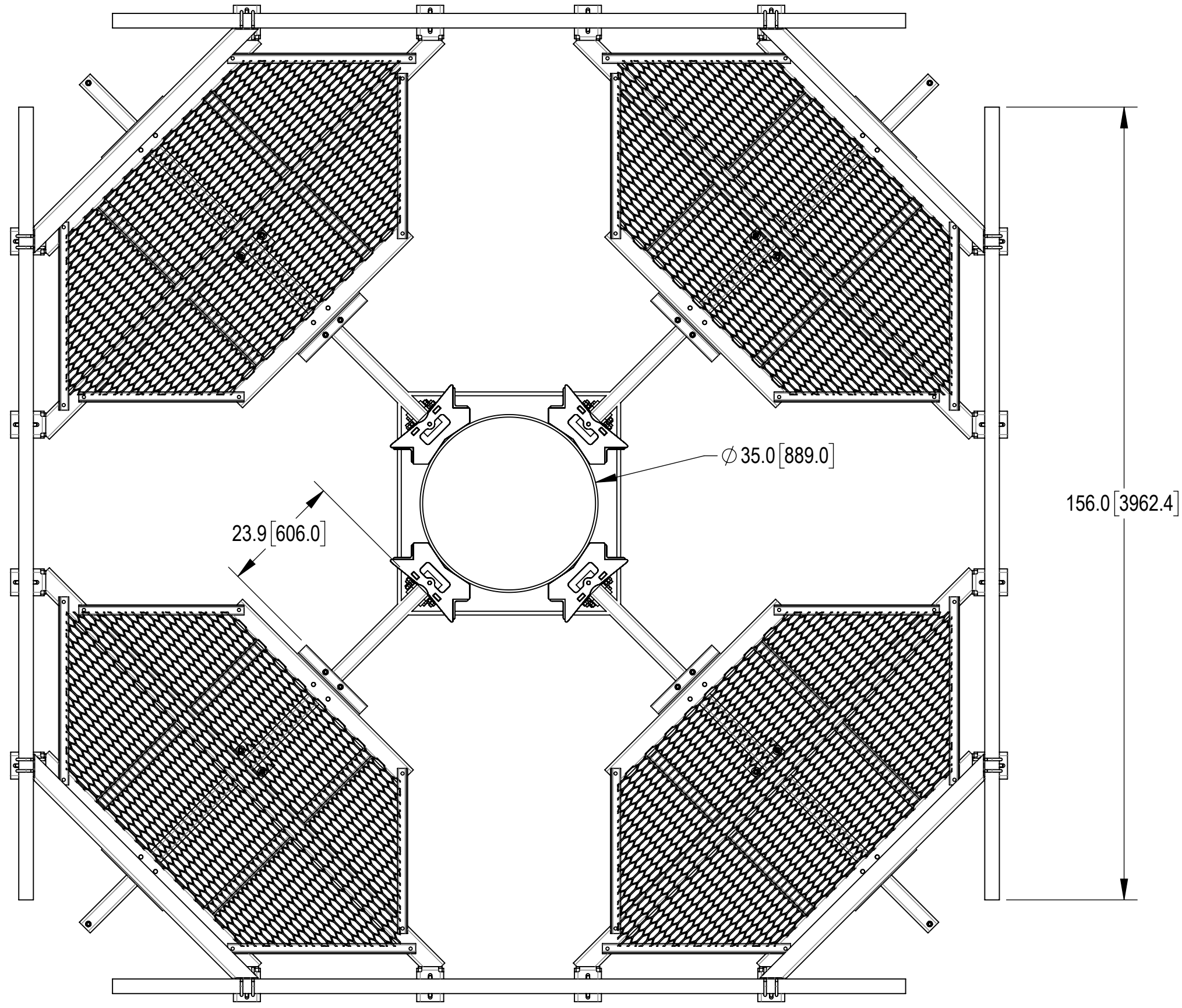

35" MONOPOLE

© 2024 CommScope, Inc. Confidential

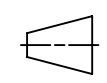
COMMSCOPE, INC. OF NORTH CAROLINA				
TITLE MP,PLF,4S,13'FP,NOAP,W/HR				
SIZE C	SCALE 1:23	DOCUMENT NO. MP-PP13M4-B		
 		DRAWING		SHEET
		VERSION 00	STATUS RE	REVISION A

4

3

2

1



4

3

2

1

D

D

C

C

B

B

A

A

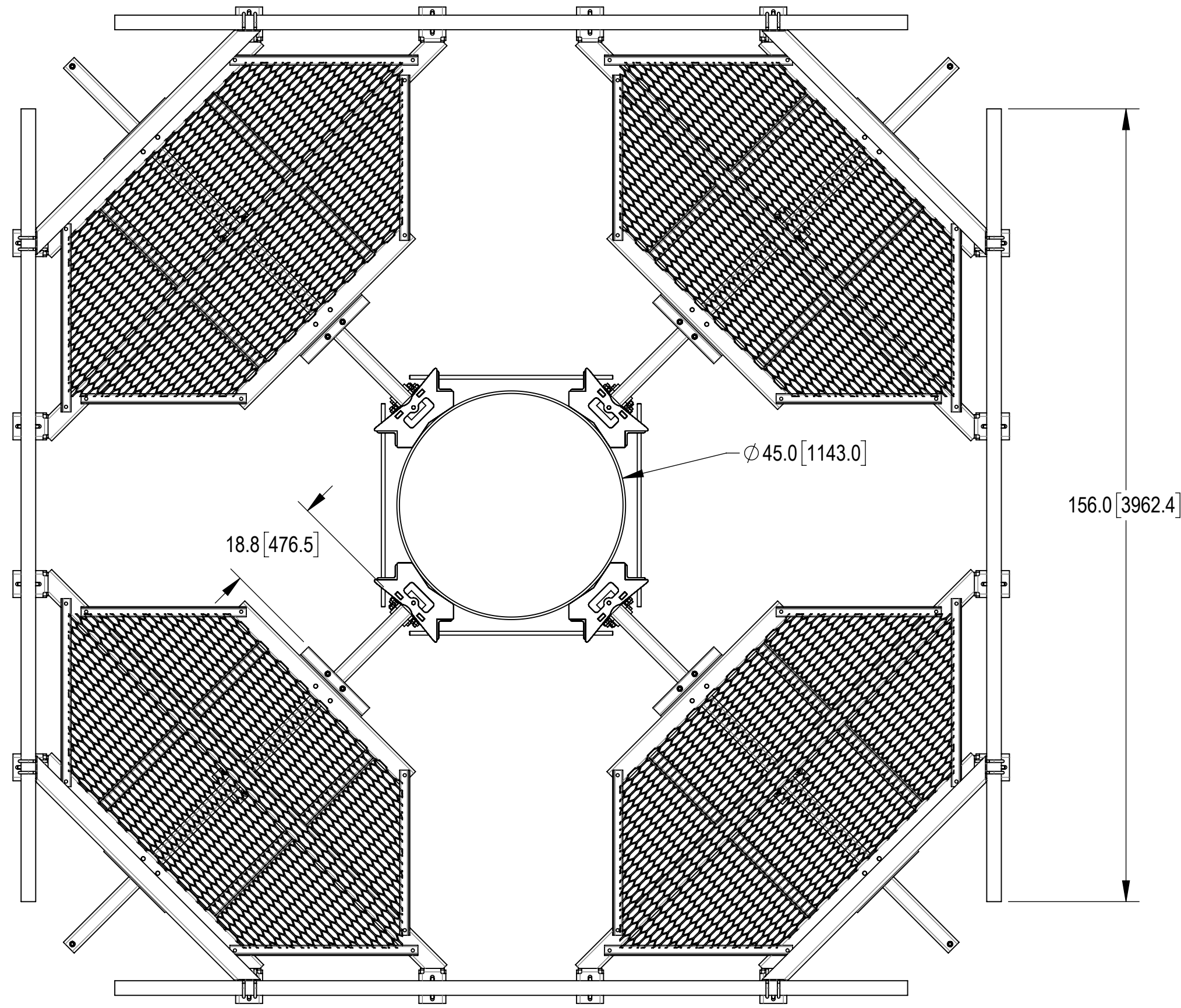

45" MONOPOLE

© 2024 CommScope, Inc. Confidential

COMMScope, INC. OF NORTH CAROLINA				
TITLE MP,PLF,4S,13'FP,NOAP,W/HR				
SIZE C	SCALE 1:23	DOCUMENT NO. MP-PP13M4-B		
		DRAWING		SHEET
		VERSION	STATUS	REVISION
		00	RE	A
				9 OF 9

4

3

2

1